

NOTE:

1. DIMENSIONS ACCOMMODATE ANSI Z245.60-2008 TYPE B CONTAINERS (DOMESTIC 2-BAR CARTS) AND MOST TYPE C CONTAINERS (EUROPEAN COMB-LIFT CARTS), BUT MAY VARY DUE TO CONTAINER SPECIFICATIONS OR APPLICATIONS.
2. ALL DIMENSIONS ARE APPROXIMATE.
3. CVTL UNITS WITH 15" OR LONGER ARMS REQUIRE A 4" MINIMUM OFFSET.
4. UNITS MARKED WITH ** HAVE A SLOW DOWN ACTUATOR.
5. FOR BOLT-ON APPLICATIONS USE MOUNTING PLATES 7900-1524.
6. PART NUMBERS: SEE CHART

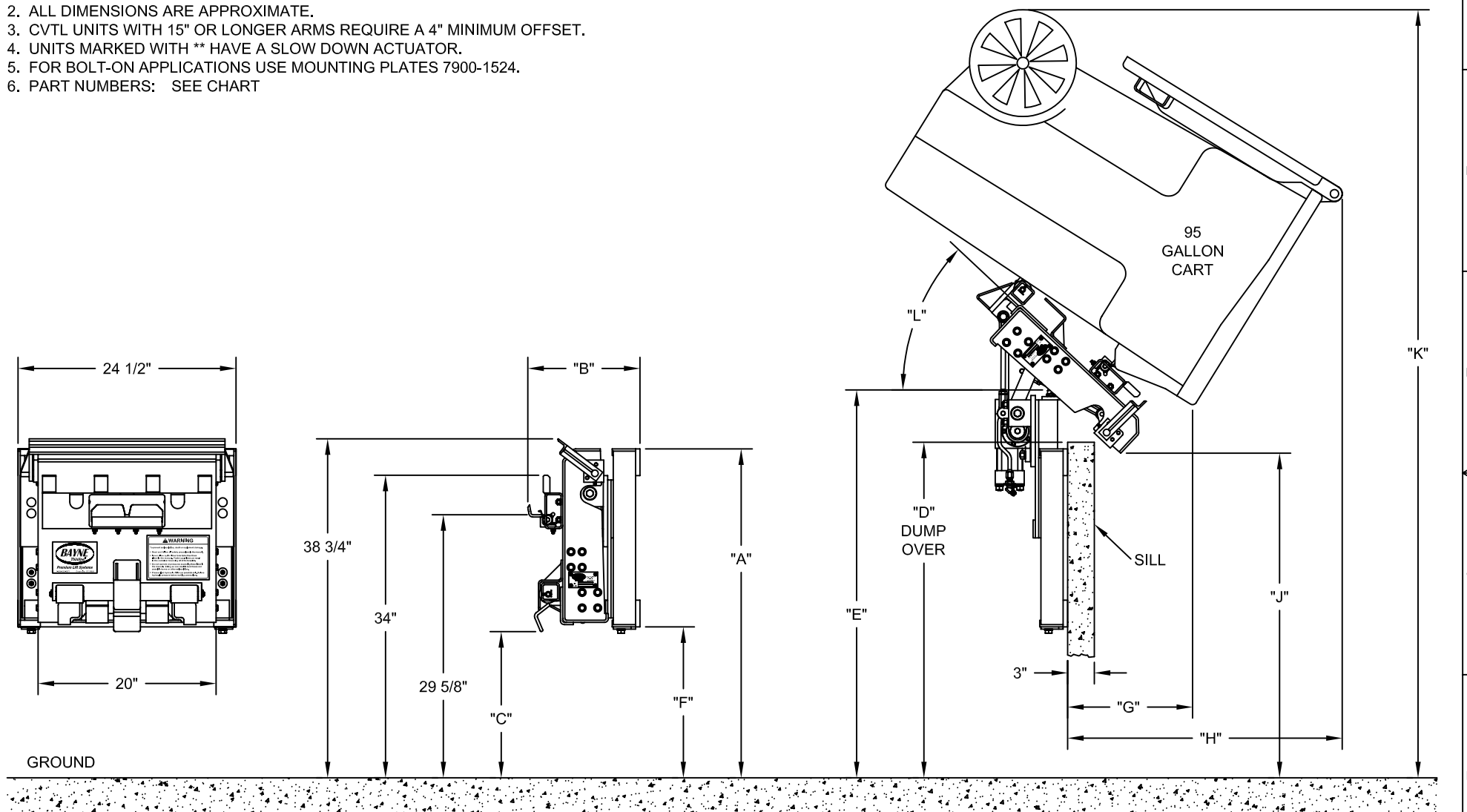

CONFIDENTIAL

THE INFORMATION CONTAINED IN THIS DRAWING IS THE SOLE PROPERTY OF BAYNE MACHINE WORKS, INC. AND IS RECALLABLE AT ANY TIME. IT MUST NOT BE COPIED OR USED DETRIMENTALLY TO THE INTEREST OF BAYNE MACHINE WORKS, INC.

UNLESS OTHERWISE SPECIFIED DIMENSIONS ARE IN INCHES
 LINEAR TOLERANCES:
 FRACTIONAL ±1/32
 TWO PLACE DECIMAL ±.015
 THREE PLACE DECIMAL ±.005
 ANGULAR TOLERANCES:
 MACHINED ±0.25 DEG
 BEND ±1.00 DEG

BAYNE MACHINE WORKS, INC.
 910 FORK SHOALS ROAD - GREENVILLE, SC 29605 - 864.288.3877

TITLE
CVTL + 9" SERIES SPECIFICATIONS

MATERIAL		DRAWN BY CTT	DATE 10/15/2009	SCALE NONE	SHEET 1	OF 2
QTY	FINISH	WEIGHT	CHECKED BY	DATE	DWG NO H0300016	REV -

MODEL NUMBER	PART #	"A" DIM.	"B" DIM.	"C" DIM.	"D" DIM.	"E" DIM.	"F" DIM.	"G" DIM.	"H" DIM.	"J" DIM.	"K" DIM.	"L" DIM.
CVTL 1110 + 9"	1960-0072	37"	12 5/8"	16 3/8"	37 3/4"	43 5/8"	17"	14"	30 7/8"	36 1/2"	86 3/8"	43°
CVTL 1115-2524 + 9"	1960-0074	42"	16 5/8"	16 3/8"	49 7/8"	48 5/8"	22"	17 1/8"	36 1/2"	45 1/4"	96"	50°
CVTL 1120-2524 + 9"	1960-0075	47"	16 5/8"	16 3/8"	60 7/8"	53 5/8"	27"	17 7/8"	35 3/8"	56 1/8"	106 1/4"	45°

CONFIDENTIAL		UNLESS OTHERWISE SPECIFIED DIMENSIONS ARE IN INCHES		BAYNE MACHINE WORKS, INC.	
THE INFORMATION CONTAINED IN THIS DRAWING IS THE SOLE PROPERTY OF BAYNE MACHINE WORKS, INC. AND IS RECALLABLE AT ANY TIME. IT MUST NOT BE COPIED OR USED DETRIMENTALLY TO THE INTEREST OF BAYNE MACHINE WORKS, INC.		LINEAR TOLERANCES: FRACTIONAL ±1/32 TWO PLACE DECIMAL ±.015 THREE PLACE DECIMAL ±.005		910 FORK SHOALS ROAD - GREENVILLE, SC 29605 - 864.288.3877	
MATERIAL		DRAWN BY CTT		DATE 10/15/2009	SCALE NONE
QTY		FINISH		WEIGHT	CHECKED BY
					DATE
					DWG NO H0300016
					SHEET OF 2 2
					REV -
					TITLE CVTL + 9" SERIES SPECIFICATIONS