

**NOTE:**

1. COMPATIBLE CONTAINERS:  
 RUBBERMAID #1314 - 1 cu yd TILT TRUCK, UTILITY DUTY  
 RUBBERMAID #1315 - 1 cu yd TILT TRUCK, STANDARD DUTY  
 RUBBERMAID #1316 - 1 cu yd TILT TRUCK, HEAVY DUTY
2. LIFT CAPACITY: 2500 lbs @ 1500 PSI
3. CYCLE TIME: 25 SECONDS @ 5.2 GPM
4. POWER UNIT: 5 HP MOTOR  
 5.2 GPM GEAR PUMP  
 12 GALLON OIL RESERVOIR  
 2500 PSI MAXIMUM PRESSURE  
 KEYED ON/OFF SWITCH
5. ALL DIMENSIONS ARE APPROXIMATE.
6. PART NUMBERS: 1920-4532 - 208V three-phase (28.6 AMPS)  
 1920-4515 - 230V three-phase (28.6 AMPS)  
 1920-4527 - 460V three-phase (14.3 AMPS)

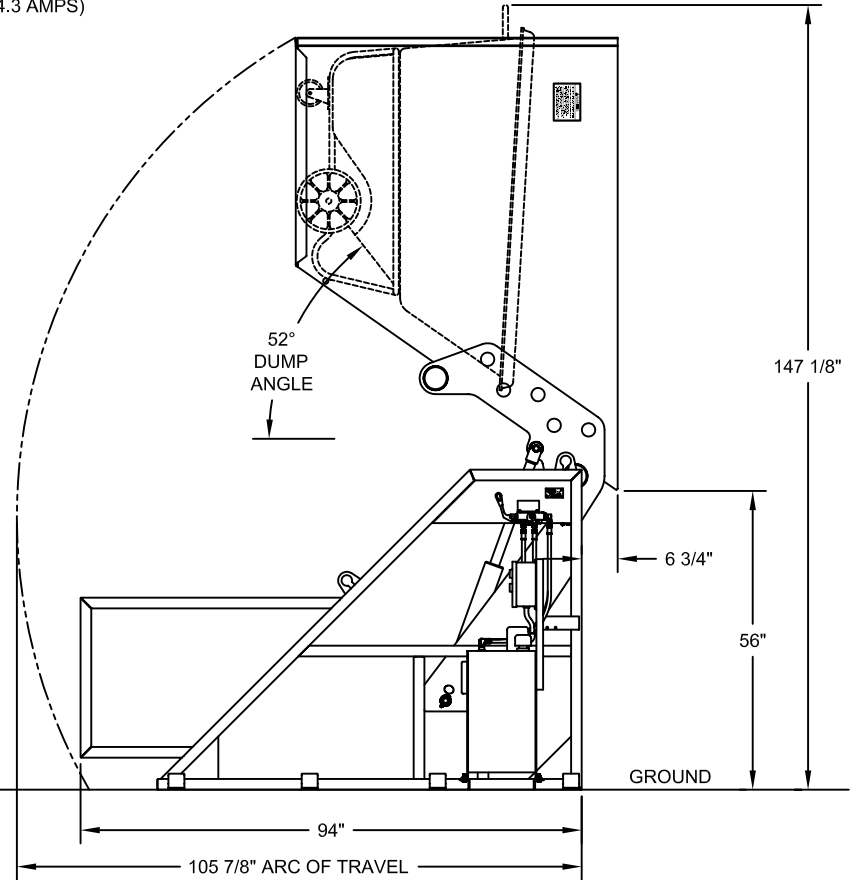
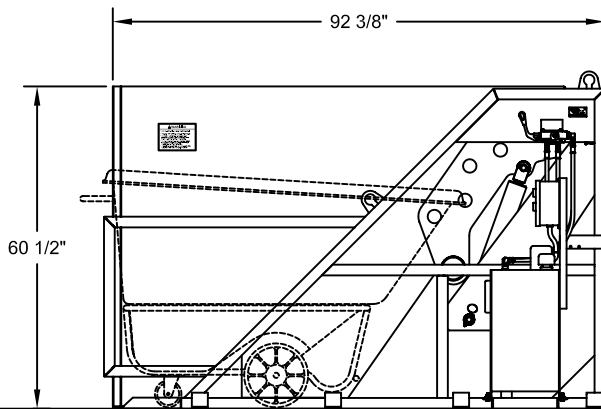
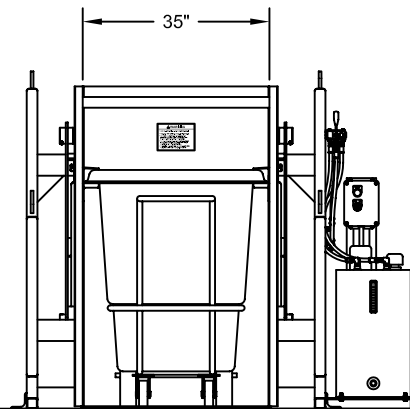

CUSTOMER APPROVAL DRAWING	
This drawing is private and confidential communication and the property of BAYNE MACHINE WORKS, INC., Greenville, S.C. It MUST NOT be copied or lent without consent of BAYNE MACHINE WORKS, INC.	<b>SUBMITTED FOR YOUR APPROVAL</b>
This drawing supersedes all drawings of previous issues. Destroy all drawings of this part number issued prior to this date:	This proposal drawing will not be released for production without a signed approval. Please review this drawing and the product shown carefully and mark all changes required.
12/02/2009	Name _____ Date _____ Title _____ Company _____

<b>CONFIDENTIAL</b>		UNLESS OTHERWISE SPECIFIED DIMENSIONS ARE IN INCHES LINEAR TOLERANCES: FRACTIONAL ±1/32 TWO PLACE DECIMAL ±.015 THREE PLACE DECIMAL ±.005 ANGULAR TOLERANCES: MACHINED ±0.25 DEG BEND ±1.00 DEG		<b>BAYNE MACHINE WORKS, INC.</b> 910 FORK SHOALS ROAD - GREENVILLE, SC 29605 - 864.288.3877	
THE INFORMATION CONTAINED IN THIS DRAWING IS THE SOLE PROPERTY OF BAYNE MACHINE WORKS, INC. AND IS RECALLABLE AT ANY TIME. IT MUST NOT BE COPIED OR USED DETRIMENTALLY TO THE INTEREST OF BAYNE MACHINE WORKS, INC.					
MATERIAL		DRAWN BY	DATE	SCALE	SHEET OF
		CTT	12/02/2009	NONE	1 1
QTY	FINISH	WEIGHT	CHECKED BY	DATE	DWG NO
					H5800022
				REV	
					-