

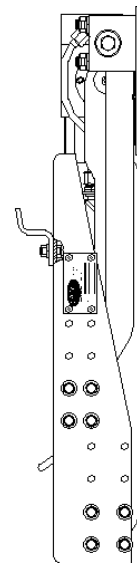

Premium Lift Systems

OPERATION AND PARTS MANUAL

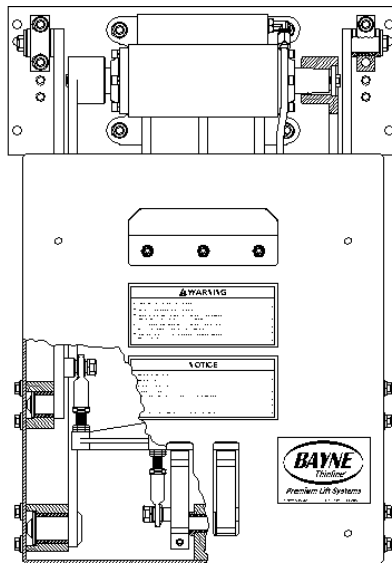

MODEL NUMBER : TL 1124

PART NUMBER : 1900-0021

SERIAL NUMBER : _____



Environmental Solutions Group
201 W. Main Street, Ste 300
Chattanooga, TN 37408
Bayne Customer Care: 800.535.2671

Cart Lifter General Operation Guidelines

Always adhere to your company's safety guidelines when using this lifter. This includes wearing appropriate clothing and personal protective equipment, including reflective gear. Keep in mind that you are operating the lifter on public roads or alleys with moving traffic. Stay vigilant and watch out for vehicles and pedestrians.

The lifter should only be used for lifting ANSI-approved carts that are in good condition. It is not designed to be used as a step, to assist in lifting commercial containers, or to crush or break down items. Use with non-approved carts or misuse can result in serious injury or damage and will void the warranty.

Make sure the area around the lifter is free of personnel before operation. Always maintain a safe distance from the lifter to avoid pinch points that can cause serious injury.

Cart lifters can hang very low to the ground at certain points in the lift cycle. It is the operator's responsibility to move the lifter to a safe position, such as raising the lifter fully or placing the lifter in the storage position before driving. Lifters left hanging low risk bottoming out on the street, road, or alley. This can cause serious damage. Damages from bottoming out are not covered by the warranty.

It is the operator's responsibility to position the cart lifter safely before approaching any obstacles. Damages from collisions are not covered by the warranty.

TABLE OF CONTENTS

	Page
I. THINLINE [®] Safety _____	3
II. THINLINE [®] Specifications _____	4
III. THINLINE [®] Installation Instructions _____	6
IV. THINLINE [®] Operation Instructions _____	13
V. THINLINE [®] Diverter Valve Information _____	16
VI. THINLINE [®] Maintenance Instructions _____	18
VII. THINLINE [®] Actuator Assembly Instructions _____	19
VIII. Trouble-shooting Chart _____	28
IX. Appendix A	
1. Unit Assembly Drawings _____	32
2. Mounting Height Drawing _____	39
3. Hydraulic Schematic Drawings _____	43
4. Diverter Valve Drawings _____	45
5. Hand Valve Drawings _____	47
6. Lubrication Drawing _____	49

SAFETY (WI-0070-A)
Bayne **THINLINE**[®] Premium Lift Systems

To prevent serious injury, death or equipment damage, read and understand this entire manual before installing, operating, repairing or adjusting your Bayne THINLINE[®] Premium Lift System. Those using and maintaining this equipment must be thoroughly trained and familiar with the product.

I. Manual:

This manual must be kept in a location that is readily available for those who operate or maintain this equipment. Additional copies may be obtained from your local dealer or directly from Bayne THINLINE[®] Premium Lift Systems.

II. Lockout/Tagout Procedures:

All applicable OSHA lockout/tagout regulations must be followed when working on this equipment. Failure to comply with these procedures can result in serious injury or death.

III. Safety Decals:

Safety decals attached to your Bayne THINLINE[®] Premium Lift System warn of hazards related to the use of this equipment. Operators must read and follow all safety instructions while using this equipment. If the safety decals are not clearly readable, new decals may be obtained from your local dealer or directly from Bayne THINLINE[®] Premium Lift Systems.

SPECIFICATIONS (WI-0081-A)
Bayne **THINLINE**[®] Premium Lift Systems

- A.** Rotary Actuator - rack and pinion style design.
- Rack, pinion, and shaft bearings are constantly lubricated by the hydraulic oil for extended life.
 - Body and caps are made of high quality ductile iron.
 - Pinion output shaft and racks are made of high tensile alloy steel.
 - The rotary actuator provides smooth motion throughout the lift cycle, which results in longer cart life with virtually no cart damage or abuse.
- B.** Arm bearings are made of a composite material which provides superior compression strength along with self-lubrication, thus eliminating the need to grease the arm bearings.
- C.** The THINLINE[®] lift unit can measure as little as 5” thick from the front of the mainframe to the front of the faceplate depending on the types of arms used. This allows for easy dumping of large commercial containers without interference.
- D.** The faceplate is normally at 45 degrees in the dump position and extends 13” to 15” from the back of the mainframe into the hopper or container opening. This places the cart or barrel 16” to 18” into the truck or container opening thus reducing any potential spillage of materials.
- E.** Cycle times for safe, fast, efficient service.
- **6 - 8 seconds** for rear-load and side-load units
 - **8 - 10 seconds** for units with 9” and 15” vertical lifts
 - **10 - 12 seconds** for stationary, recycling, and double wide, and 24” vertical units
 - **15 - 30 seconds** for 3300 series and 3300 series stationary units
- Note : Cycle time is controlled by flowrate, as flowrate increases, cycle times decrease.*
- Warning : Never exceed the cycle times listed above. In order to avoid injury and maintain manufacturer’s warranty never operate outside of these recommendations.**
- F.** Recommended flowrates are as follows:
- **2 to 2 1/2 GPM** for 1100 series units
 - **2 to 4 GPM** for 2200 series units
 - **2 1/2 to 6 GPM** for 3300 series units
- G.** Hydraulic pressure requirements are as follows:
- **2000 to 2500 PSI** normal working pressure
 - **3000 PSI** maximum pressure
- H.** All lifters can be a bolt on type installation for easy, quick maintenance and less downtime.

- I. All parts are manufactured and kept in stock at Bayne Machine Works, Inc. for fast response to customer request.
- J. Two (2) year limited warranty from date of delivery on all units and models when properly maintained and operated within the recommended cycle time.

All lift units and parts are inspected by our Quality Control Department before shipment to insure that you always receive the highest quality available in the lift business.

For more information, please contact us at 1/800/535-2671 or by fax at 1/864/458-7519.

INSTALLATION INSTRUCTIONS (WI-0104-C)

Bayne *THINLINE*[®] Premium Lift Systems

The following information is intended to be a **GENERAL GUIDE** to installing the Bayne *THINLINE*[®] lifter on a typical refuse truck. Before starting the installation, read these instructions completely. **ALWAYS** use the proper tools, lift devices, and personal protective equipment to prevent injury while performing the installation.

NOTE: If a Bayne *THINLINE*[®] Tap-In Kit was also acquired for this installation, refer to the installation instructions included in the Tap-In Kit manual for more detailed information.

IV. Mounting lifter(s) on the truck :

1. The truck should be emptied and cleaned before any installation. The truck should be parked on a level solid surface, a concrete floor if possible.
2. All lights, tags, steps, etc. that will interfere with the installation should be removed and/or relocated.
3. Position the lifter(s) on the sill of the truck per *figure I-1* and mounting height drawing (*Appendix A*) and tack weld in place. If using an “S” unit for bolt on applications, tack weld the mounting plate in place and attach the lifter to the mounting plate using the 1/2” studs. (*tack weld only at this time so that adjustments can be made if necessary.*).

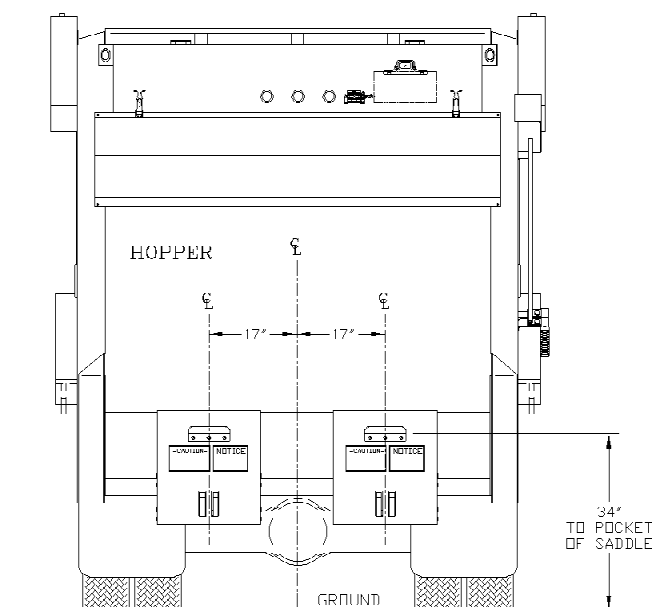

figure I-1

V. Mounting hand valve(s) on the truck :

1. Choose and mark an acceptable location(s) on the side(s) of the truck to mount the hand valve assembly(s) (*figure I-2*).
2. Remove the mounting bracket(s) from the hand valve assembly(s) and weld to the truck.
3. After the weld has cooled, paint the mounting bracket(s) to match the truck color.
4. After the paint has dried, reassemble the hand valve assembly(s) on the mounting bracket(s).

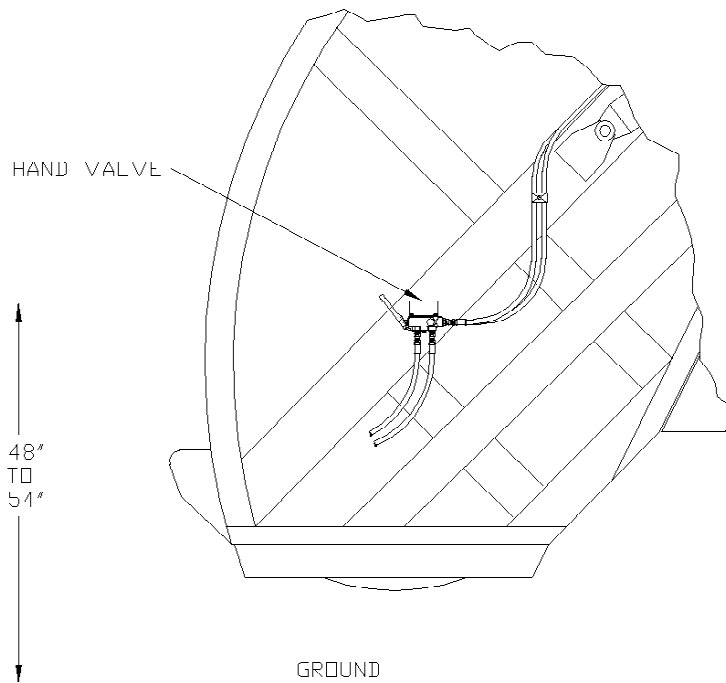

figure I-2

VI. Mounting diverter valve on the truck :

1. Choose and mark an acceptable location to mount the diverter valve assembly. This location should be near the truck's main hydraulic pressure and tank lines on the same area of the truck where the lifter is mounted.
2. Weld diverter valve mounting bracket to the truck.
3. After the weld has cooled, paint the mounting bracket to match the truck color.
4. After the paint has dried, bolt the diverter valve to the mounting bracket using the 1/4" bolts, washers, and elastic lock nuts.

VII. Making Hydraulic Connections :

Before attempting any hydraulic connections, turn the truck's engine off and release all hydraulic pressure from the system. Refer to the hydraulic layouts (figure I-3) and hydraulic schematics (Appendix A) while performing the following steps. Always clean & lubricate fitting threads before installation.

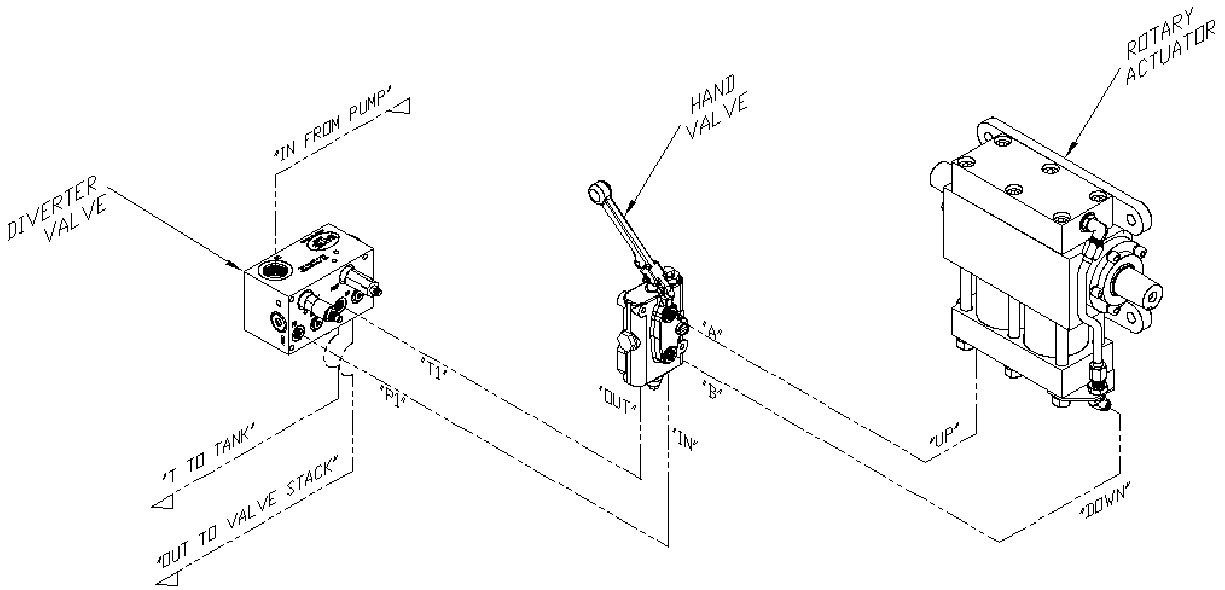

Single Lifter Installation

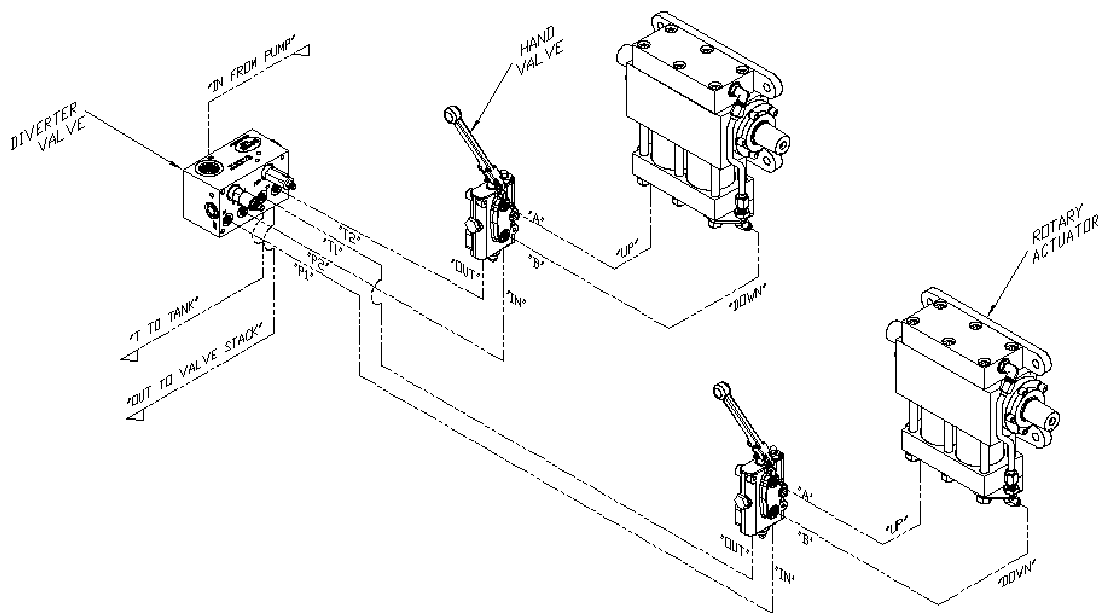

Dual Lifter Installation

figure I-3

1. Cut or disconnect truck's main hydraulic pressure line and install the diverter valve in series using the "IN" and "OUT" ports.
2. Connect the "T" port on the diverter valve to the truck's hydraulic tank line with an appropriate size line to handle the lifter system flow. (approximately 5 GPM max.)
3. Connect the "P1" port on the diverter valve to the "IN" port on the hand valve.
If installing dual lifters, connect the "P2" port on the diverter valve to the "IN" port on the other hand valve.
4. Connect the "T1" port on the diverter valve to the "OUT" port on the hand valve.
If installing dual lifters, connect the "T2" port on the diverter valve to the "OUT" port on the other hand valve.
5. Connect the "A" port on the hand valve(s) to the "UP" port of the rotary actuator(s).
6. Connect the "B" port of the hand valve(s) to the "DOWN" port of the rotary actuator(s).
7. Disassemble each hose clamp assembly and position weld plates where needed and weld in place.
8. After the weld has cooled, paint the weld plates to match the truck color.
9. After the paint has dried, reassemble the hose clamp assemblies around the hoses.

VIII. Adjusting relief valve settings :

The diverter valve (1) (figure I-4) supplies the cart lifter hydraulic system with approximately 2 GPM of oil flow. This diverter valve is equipped with a lifter circuit relief valve (3) set at 2300 psi, to prevent the diverter valve from shutting down if a blockage occurs in the lifter circuit. There is also a relief valve (5) set at 1800 psi in the hand valve (2) to protect the lifter from excessive pressure. These relief valves are preset from the factory to operate properly on most trucks with a system pressure between 2300 and 2500 psi without any adjustment. However, if any adjustment is necessary, follow these instructions.

WARNING : *Bayne equipment is rated for a maximum pressure of 3000 psi. Operation at pressures above 3000 psi may damage equipment and cause personal injury. In order to avoid injury and maintain manufacturer's warranty never operate above 3000 psi.*

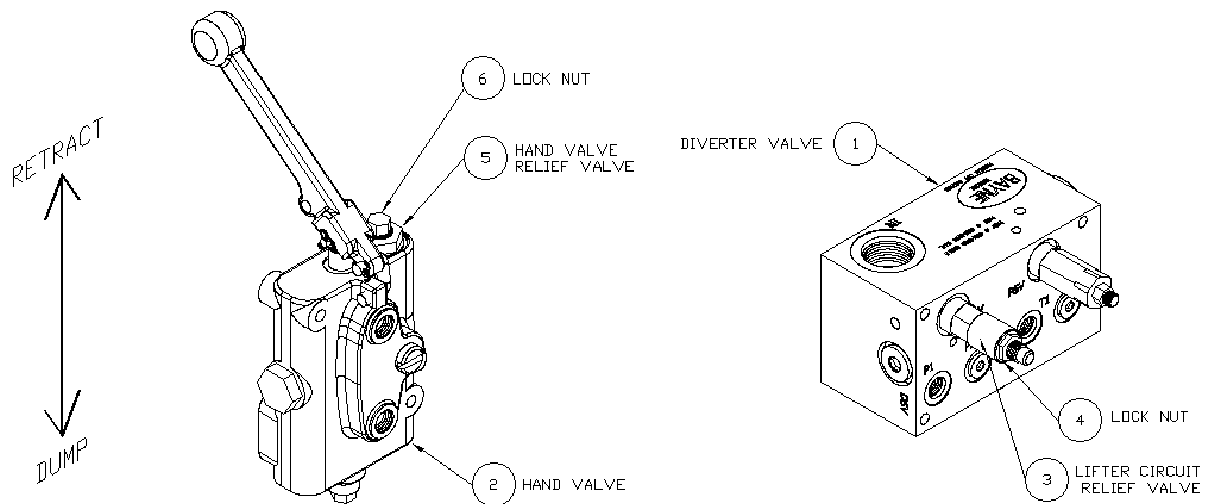

figure I-4

1. Determine the truck's system pressure setting.
2. Loosen lock nut (6) (*figure I-4*) from the hand valve relief valve(s) (5) and turn the adjustment screw(s) clockwise until it bottoms out.
3. Loosen the lock nut (4) (*figure I-4*) on the lifter circuit relief valve (3) and turn the adjustment screw clockwise until it bottoms out.
4. Start the truck's engine and engage the hydraulic system.
5. Operate the handle on the hand valve (2) (*figure I-4*) back and forth a few times to bleed all air from the lifter hydraulic system.
6. Turn the truck's engine off and release all hydraulic pressure from the system.
7. Install the 3000 psi hydraulic pressure gauge with the necessary adapter in the hydraulic line connected to the "IN" port of the hand valve as shown in figure I-5. *If installing dual lifters, install the hydraulic gauge at either one of the hand valves.*

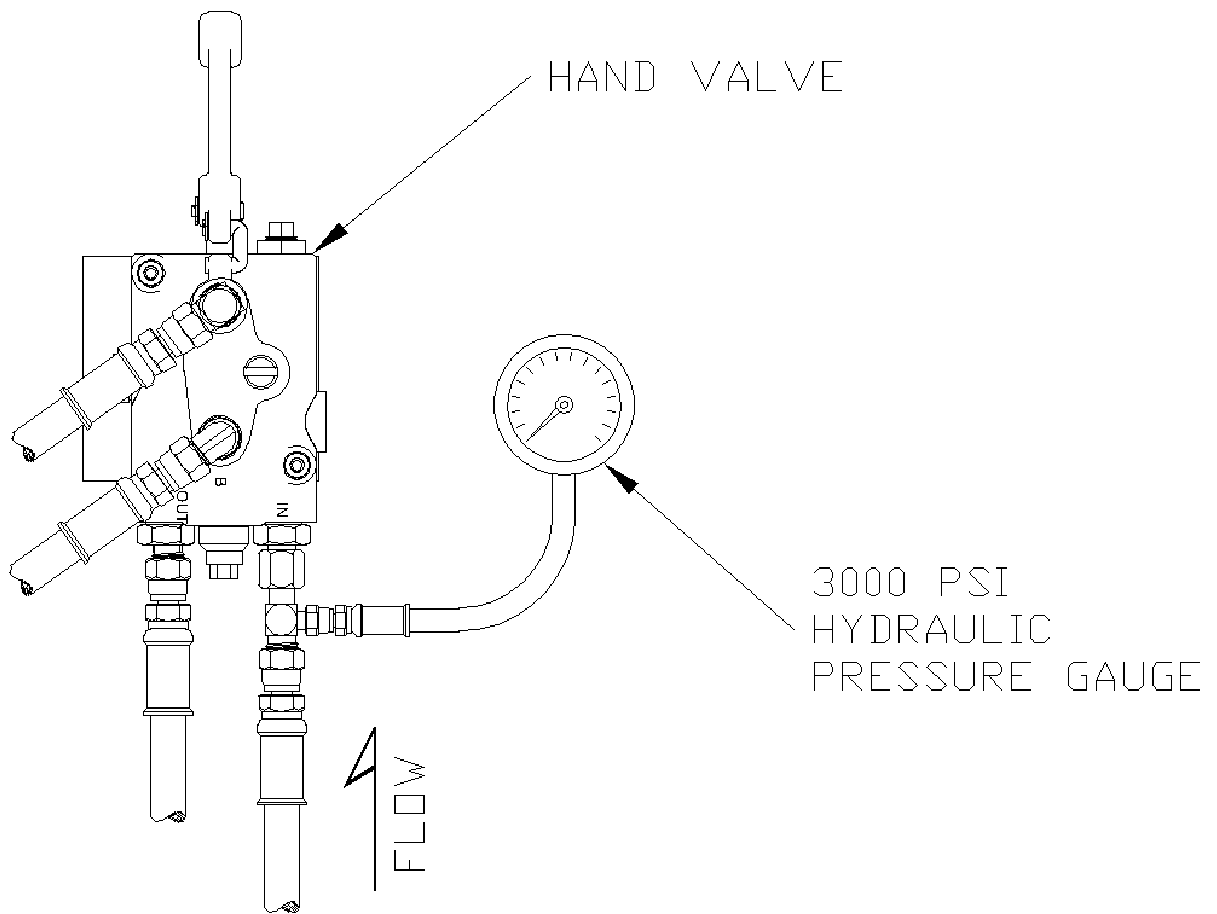

figure I-5

8. Start the truck's engine and engage the hydraulic system.
9. **Setting the diverter valve lifter circuit relief valve :**
 - a) Have an assistant hold the handle on the hand valve (2) (*figure I-4*) (*with pressure gauge installed at the "IN" port*) in the "retract" position to show pressure on the gauge.
 - b) Turn the pressure relief adjusting screw on the lifter circuit relief valve (3) counter-clockwise until the pressure reading on the gauge is either 100 psi less than the truck system pressure or 2300 psi, which ever is the lowest.
 - c) Release the handle on the hand valve.

10. Setting the hand valve relief valve(s) :

- a) Hold a handle on the hand valve (2) (*figure I-4*) (*with pressure gauge installed at the “IN” port*) in the “retract” position to show pressure on the gauge.
 - b) Turn the pressure relief adjusting screw on the hand valve relief valve (5) counter-clockwise until the pressure reading on the gauge is either 200 psi less than truck system pressure or 1800 psi, which ever is the lowest.
 - c) Release the handle on the hand valve.
 - d) Turn the truck’s engine off and release all hydraulic pressure from the system.
 - e) Remove the hydraulic pressure gauge from the hydraulic line connected to the “IN” port of the hand valve.
 - f) *For dual lifters, install the hydraulic pressure gauge in the “IN” port of the other hand valve as shown in figure I-5, start the truck’s engine, engage the hydraulic system, and repeat step 10.*
11. Reinstall the cap nut(s) (6) (*figure I-4*) on the hand valve relief valve(s) (5) to secure the correct pressure setting(s).
 12. Tighten the lock nut (4) (*figure I-4*) on the lifter circuit relief valve (3) to secure the correct pressure setting.
 13. The hydraulic circuit pressures are now set for optimum performance.

VI. Final operation and mounting:

1. Start the truck’s engine and engage the hydraulic system.
2. Place a cart on each lifter and operate to make sure there are no clearance problems and that the lifter engages the cart properly. Make any adjustments to the mounting position of the lifter(s) to ensure correct operation.
3. After locating an acceptable mounting position, complete the welding of the lifter(s) to the truck.

OPERATION INSTRUCTIONS (WI-0124-A)

Bayne *THINLINE*[®] Premium Lift Systems

The Bayne *THINLINE*[®] Premium Lift System is a high quality durable cart lifter built to meet your industry's requirements. To insure the safety of all operators of this equipment, please read this manual carefully before operating the lifter. *FAILURE TO COMPLY WITH INSTRUCTIONS COULD RESULT IN PERSONAL INJURY AND/OR PROPERTY DAMAGE.*

The operating stages (figure O-1) in the cycle of the cart lifter are as follows:

- 1) **START** - The cart to be dumped is placed on the lifter.
- 2) **ACTUATOR DUMP** - The rotary actuator cycles to dump the contents of the cart into the box. During this cycle, the lower hooks automatically rotate to "lock" the cart to the lifter.
- 3) **ACTUATOR REVERSE** - The rotary actuator reverses its cycle returning the cart to the start position. The lower hooks automatically retract to "unlock" the cart from the lifter.

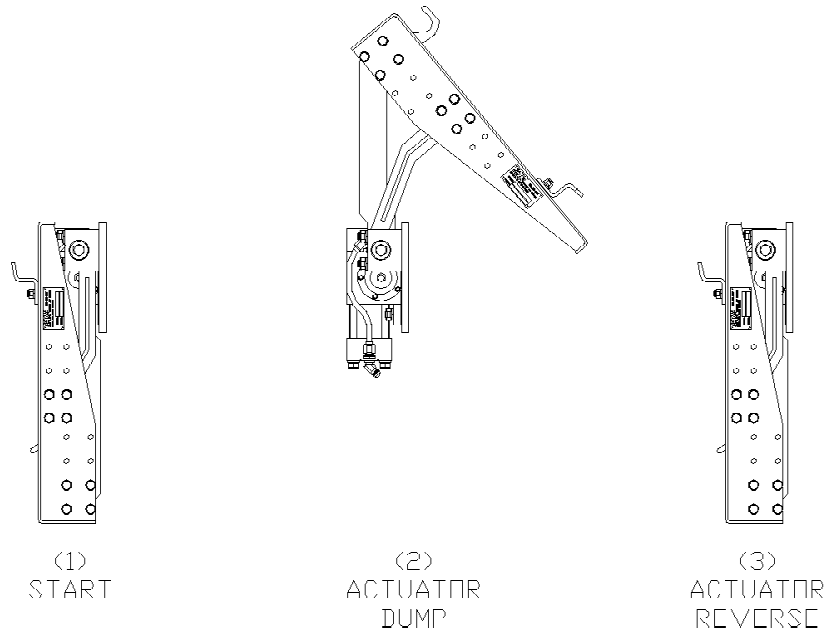

figure O-1

Warning: Exceeding the recommended cycle time on any lifter will void the manufacturer's warranty

The rotational motions of the cart lifter are controlled with the use of a hand valve. Moving the handle on the hand valve in one direction will cause the lifter to perform the actuator dump stage (figure O-1). Moving the handle in the opposite direction will cause the lifter to perform the actuator reverse stage.

SAFETY ZONES

Stand Clear Zone

To prevent serious injury or death, operators and bystanders should remain outside the Stand Clear Zone (figure O-2) at all times during the operating cycle of the lifter. If at any point during the cycle persons enter this area, the operator must stop all motion of the lifter until the area is cleared.

Dump Zone

To prevent serious injury or death, operators and bystanders should remain outside the Dump Zone (figure O-2) at all times. If it becomes necessary to enter this area, all applicable OSHA lockout/tagout regulations must be followed.

Operator Area

To provide a clear, unobstructed view of both the Stand Clear Zone and Dump Zone, operators should remain within the Operator Area (figure O-2) at all times during the operating cycle of the lifter.

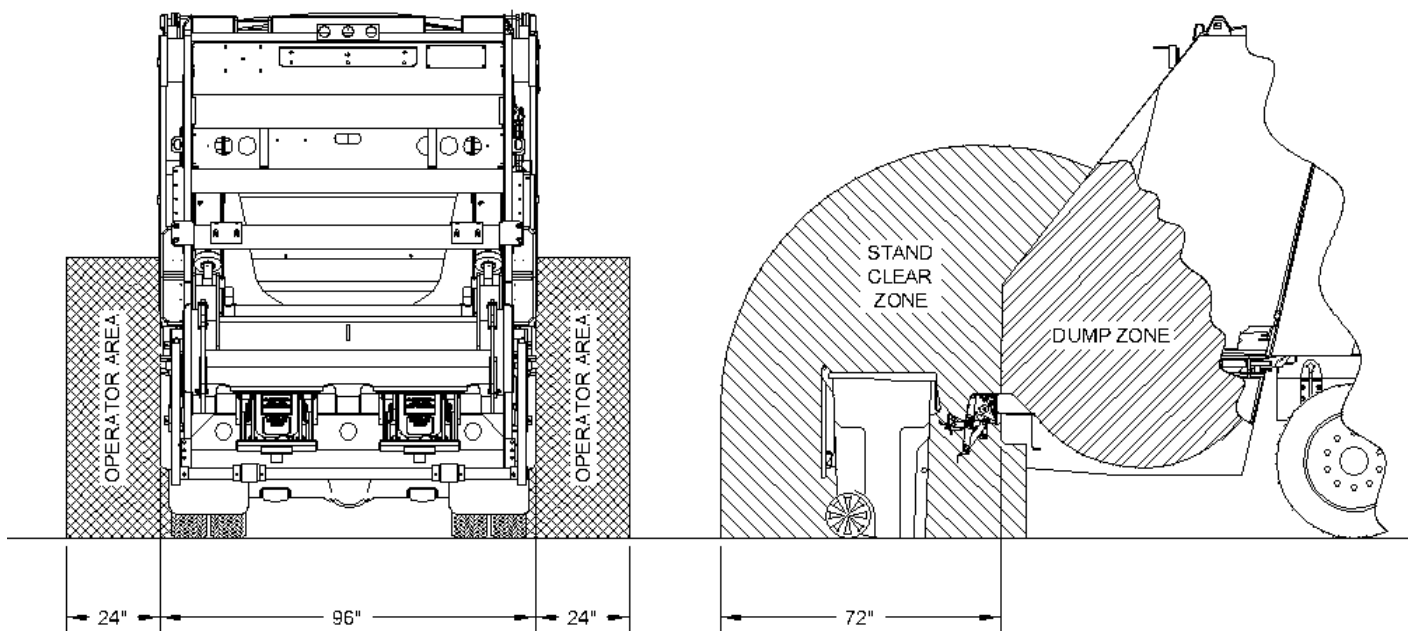

figure O-2

LOWER HOOK ADJUSTMENT

Check the distance (**A**) (figure O-3) between the saddle and lower hooks when the lifter faceplate is in the **FULL DUMP** position. Maintain this dimension at approximately **14 1/4"** for the proper "locking" of the cart to the lifter. To adjust the setting, loosen the jam nuts (1) on the spherical rod ends (2). Remove the bolts (3) that hold the rod ends to the lower hooks (4). Screw the rod ends in or out as required to obtain the correct dimension at (**A**). Replace the bolts (3) and tighten the jam nuts (1).

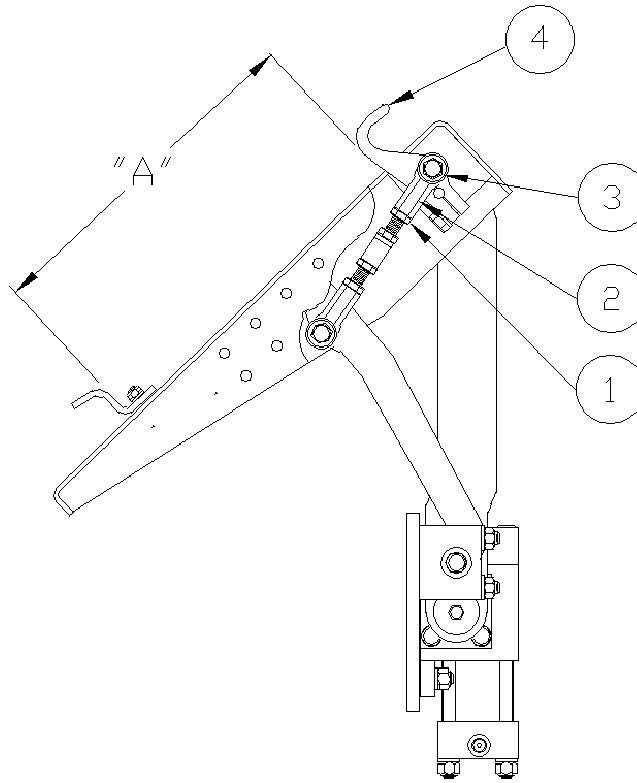

figure O-3

CAUTION: *The distance in figure 0-3 is an arbitrary figure based on information furnished by cart manufacturers. It is the responsibility of the owner / operator of this equipment to adjust these dimensions to be compatible with his specific application.*

6091/6092-0700 DIVERTER VALVE
OPERATION AND INSTALLATION INFORMATION
(WI-0026)

Bayne *THINLINE*[®] Premium Lift Systems

The Bayne diverter valve establishes priority flow to the lifter circuit “P1” and “P2” ports and bypasses oil to the “OUT” port, which typically supplies flow to the remainder of the truck’s hydraulic circuit. This bypass occurs only after the lifter circuit is satisfied. The priority flow is controlled by the flow regulator cartridge (FR1) (and FR2 in dual applications) in combination with the differential pressure sensing valve (DPS). This allows the valve to maintain constant flow regardless of changes in load pressure or volume flow rate. Since both the lifter circuit and bypass flow can be utilized in the operation of the truck regardless of which pressure is greater, a single pump can be used to supply two circuits or operations.

The lifter circuit flow is regulated and maintained by the flow regulator cartridge (FR1) (and FR2 in dual applications). The differential pressure sensing valve (DPS), rated for 75 gpm of flow and 3000 psi of pressure, is operated by an internal spring and dampening orifice (OR) which establishes a pressure drop across the block sufficient to ensure the correct operation of the flow regulator (FR1). For a dual diverter valve, a second flow regulator cartridge (FR2) is installed in the “FR2” cavity and a shuttle valve (DSV) is installed in place of the SAE plug in the “DSV” cavity. Once the pressure drop is established, a precision metered flow is provided to the tipper circuit(s) with additional flow being bypassed to the “OUT” port.

The operation of the diverter valve does not require the use of a tank line to be run to the “T” port. However, the efficiency of the block will be significantly increased if a tank line is installed. The logic circuit of the block will manage the flow of oil returning from the tipper circuit to ensure optimum performance. This is primarily controlled with the sequence valve (PSV) which is factory set and should not be adjusted. All oil returning from the tipper circuit will normally be regenerated into the outgoing flow to ensure that the downstream functions are not slowed in any way. When the downstream backpressure rises to a predetermined pressure, the block will redirect the flow to the “T” port to increase the overall efficiency of the block and reduce the pressure drop through the block. If the “T” port is connected to a tank line, the oil will be dumped through the block at a lower pressure. This allows downstream functions to operate at the highest possible pressure when pressure is being required. If the “T” port is blocked, the oil will be redirected back into the outgoing flow through the check valve (CV).

A relief circuit for the tipper function is controlled by a relief valve (RV), which is preset to 2300 psi. This can be adjusted to limit pressure to the tipper(s). This relief valve is more efficient than the relief in the hand valve and will operate with less noise. It is recommended that it be adjusted to relieve before the hand valve relief. It may also be used to limit the weight the lifter can dump. This may be beneficial in avoiding damage to cans resulting from overloading. This should be the only adjustment that the block may require. Any other adjustments should only be made after close consultation with Bayne’s Engineering Department to ensure proper operation.

POSSIBLE PROBLEMS

1. The most common cause of valve failure is dirty oil. If debris becomes lodged in the cartridge valves they will malfunction. Recommended filtration level is between 15 and 25 microns. Many systems filter the oil on the return side. This does not guarantee clean oil going into the system. It is important to ensure that the tank vent filtration element is properly maintained as well. Very small contaminants may not cause the valve to stop functioning, but can cause “stiction” in the cartridges between the body and the moving spool. This can cause improper operation. A slow moving tipper is most likely the result of contamination in the flow regulator cartridge. A pulsating noise may be the result of contamination in the differential pressure sensing valve causing it to stick. If any valve malfunctions, remove and thoroughly clean the valve, being extremely careful not to score or abrade the “o” ring seals or moving parts of the valve. Be sure that the spool moves freely in the valve body.
2. The flow regulator cartridges (FR1 and FR2) are designed to operate at a designated pressure of 80 psi. This means that in order for the valve to function properly, a minimum of 80 psi is required from the supply line through the “IN” port of the valve. This can present a problem on trucks with a dry valve pump system. Normally in the dry (off) mode of the pump, a flow of approximately 2 gpm at 20 psi is required to circulate through the open center system of the truck. This is for pump lubrication in the off mode. When the diverter valve is placed in the main pressure line of the truck, a blockage occurs because of the differential pressure sensing valve needing 80 psi to initially open and allow the flow regulators function. The path of the lubrication oil is therefore stopped because the valve does not open. When the oil is blocked, the pump will rotate and cavitate in the lubricating oil, causing heat to build up over an extended period of time, possibly leading to premature pump failure. To prevent this problem from occurring, a “bleed line” circuit needs be installed on the truck to allow passage of the lubricating oil back to tank.
3. On front load residential truck applications, several considerations need to be noted. The Bayne hand valve is an open center valve that allows for the lifter circuit to maintain flow through the hand valve and back to the diverter valve when the lifter is not being operated. If flow is not maintained through the hand valve, the oil will constantly be relieving over the lifter circuit relief valve (RV) in the diverter valve, which can cause an increase in operating temperature. Certain front load box designs allow for the hand valve to be located on the arms of the truck which keeps the hand valve in the lifter circuit at all times to maintain flow. Most problems occur with applications where the hand valve is located on the box itself. In this situation, when the operator disconnects the hydraulic lines to the box, a blocked condition occurs in the lifter circuit. To prevent this problem, the pump must be turned off prior to disconnecting the box hydraulic lines. Once the lines have been disconnected from the box, it is necessary to connect the two lines for the hand valve to each other to functionally complete the lifter circuit. It is recommended that male and female quick disconnects be used opposite each other on the truck to provide an uninterrupted circuit. Once the lines have been connected and the circuit continued, the pump could then be turned on to continue operations.

MAINTENANCE INSTRUCTIONS (WI-0140-A)

Bayne ***THINLINE***[®] Premium Lift Systems

NOTE:

THE MOST COMMON CAUSE OF HYDRAULIC COMPONENT FAILURE IS CONTAMINATION OF THE HYDRAULIC FLUID (WATER, CHIPS, DIRT, ETC.) THE Bayne ***THINLINE***[®] LIFT SYSTEM COMES CLEAN FROM THE FACTORY. IF REMOVED, BE SURE THE HOSES, CYLINDER AND FITTINGS ARE CLEAN BEFORE RE-INSTALLING THEM ON THE UNIT.

Inspect your cart lifter on a weekly basis for loose bolts, fittings, oil leaks, etc. Tighten loose hardware as necessary and replace necessary seals to repair oil leaks.

In order to maintain warranty and for preventive maintenance, grease all points weekly with a good multi-purpose grease at points shown in the lubrication drawing (*APPENDIX A*).

BAYNE

PREMIUM LIFT SYSTEMS

ASSEMBLY INSTRUCTIONS

1100 SERIES ROLLER BEARING ACTUATOR

PART NUMBER 1120-1025 (WI-1109-E)

LICENSED UNDER ONE OR MORE OF THE FOLLOWING U.S. PATENTS:
4,773,812 1,327,765 5,308,211 5,333,984

READ INSTRUCTIONS COMPLETELY BEFORE STARTING ASSEMBLY.

Before starting the assembly of the Rotary Actuator, refer to the exploded parts drawing and parts list (fig. A-13 found at the end of these instructions) to familiarize yourself with the individual components. Prepare a clean surface, in an area free of blowing dust and contaminants in which to assemble the Rotary Actuator. Be sure that all parts are thoroughly clean and dry before starting assembly.

NOTE: All torque values given apply to clean dry threads only. Follow these directions closely when repairing the Rotary Actuator.

1. Install the piston seal load ring (13) (fig. A-1) in the small groove on the head of the actuator rack (2). Place the “square” piston seal (17) over the load ring (13) in the same small groove (a small “blunt” flathead screwdriver may be used, taking care not to scratch or damage the seal). Install the wear ring (18) in the large groove on the head of the rack. Using a ring compressor, firmly seat the rings on the rack before setting it aside, this will help to reverse the effects of any stretching of the rings that occurred during installation. Repeat this procedure for the other rack.

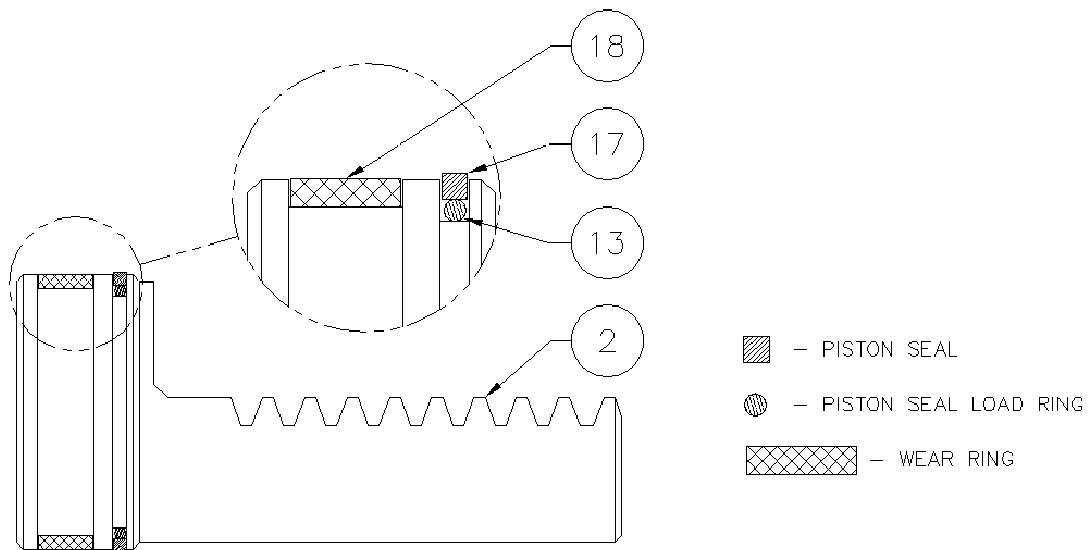

figure A-1

2. Install the tube seal (12) (fig. A-2) and “square” tube seal backup (16) on each end of the actuator tubes (3) (fig. A-13). Be sure that the “square” tube seal backup ring is toward the inside of the tubes at both ends as shown. Press all rings firmly into the grooves. Repeat this procedure for the other tube.

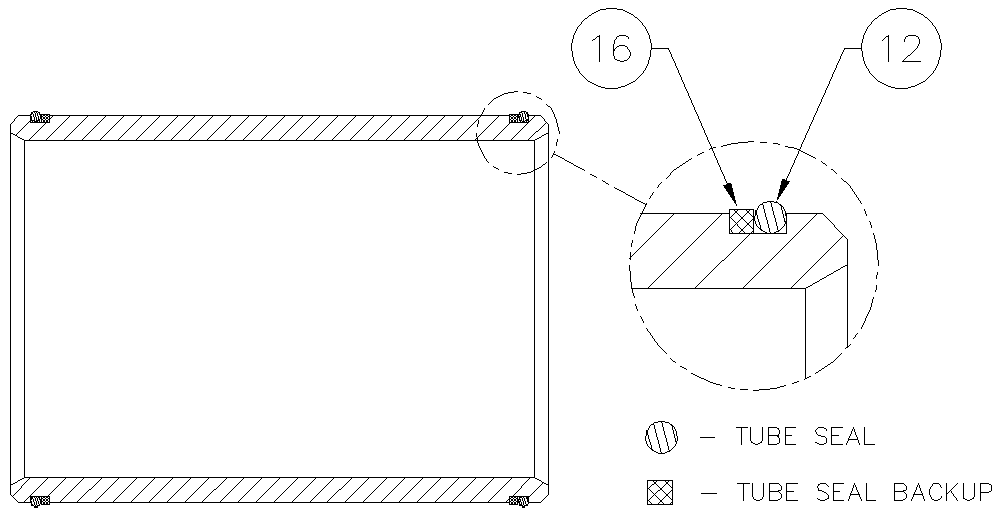

figure A-2

3. Thoroughly clean the pinion shaft (1) (fig. A-3) and inner races (10) with a mild solvent and dry completely. Spray the inner race contact area (shown in figure A-3) at each end of the pinion shaft and the inside diameter of the inner race thoroughly with *LOCTITE 7649 N PRIMER*. Apply *LOCTITE RETAINING COMPOUND 609* around the pinion shaft at contact area and the inside diameter of the inner races. Slide the inner races (10) on the pinion shaft (radius end first as shown in figure A-3) until the races seat against the gear teeth. After the races seat against the gear teeth, twist the races on the pinion 360° to spread the retaining compound evenly. Wipe off any excess retaining compound.

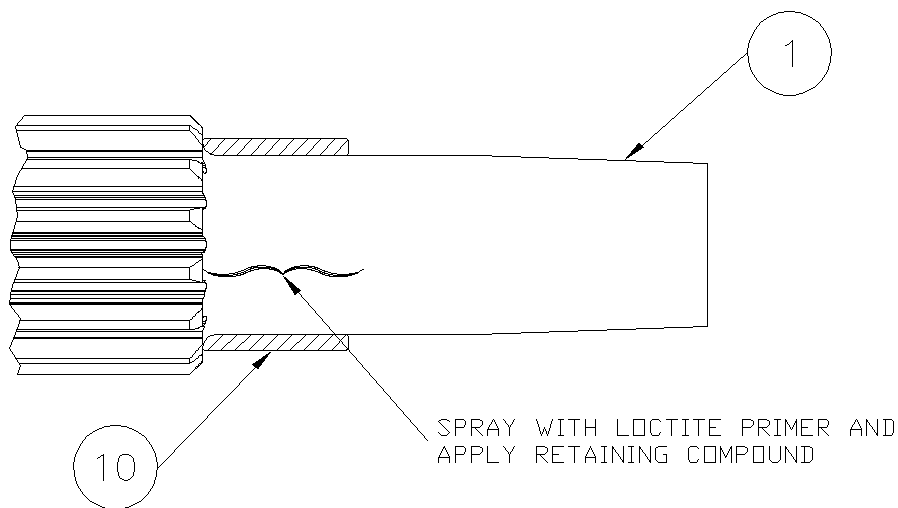

figure A-3

- Place the actuator body (7) (fig. A-4) on the edge of the table, mounting flanges closest to the assembler with the counter-bores facing up. Insert the pinion shaft (1) through the bore on either side of the actuator body with the key ways facing back toward the mounting flanges and up away from the table with the center line of the key ways pointing toward the center of the tapped hole shown in figure A-4. Center the pinion in the actuator body.

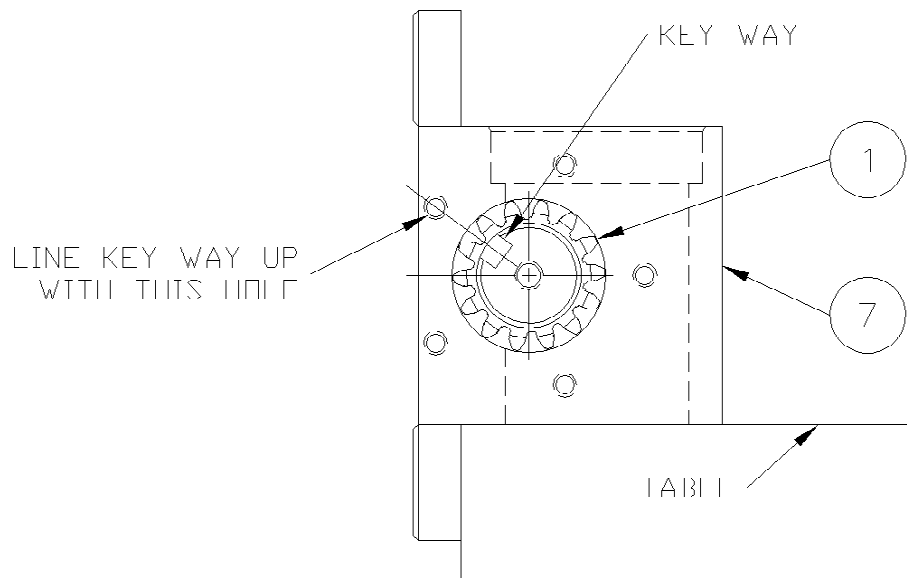

figure A-4

- Coat the head portion of the racks (2) (fig. A-13) with STP Oil Treatment. Install the racks, head portion up with the teeth facing the flanges of the actuator body, into the dual set of bores in the body. Simultaneously slide the racks into the bores so that the racks mesh with the pinion in the same position. Rotate the pinion shaft to engage the racks into the pinion.

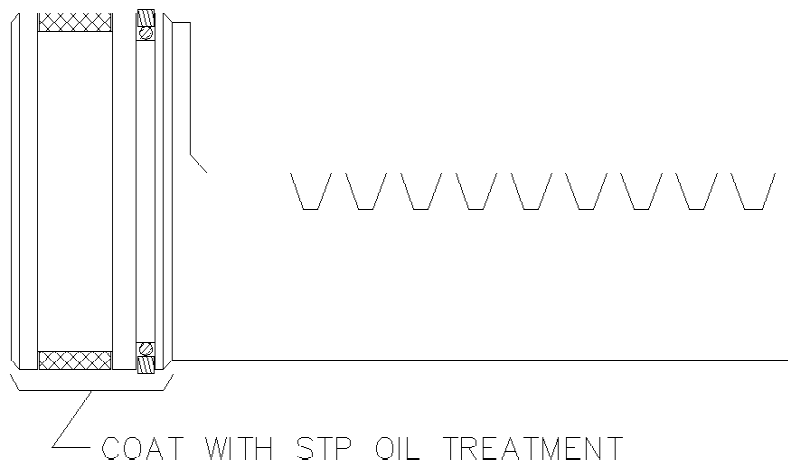

figure A-5

6. Check the position of the racks in the pinion by making sure both racks seat against the actuator body at the same time and also when the racks are seated against the body, the key ways on the pinion shaft should be facing down toward the table and very slightly back toward the mounting flanges on the actuator body as shown in figure A-6.

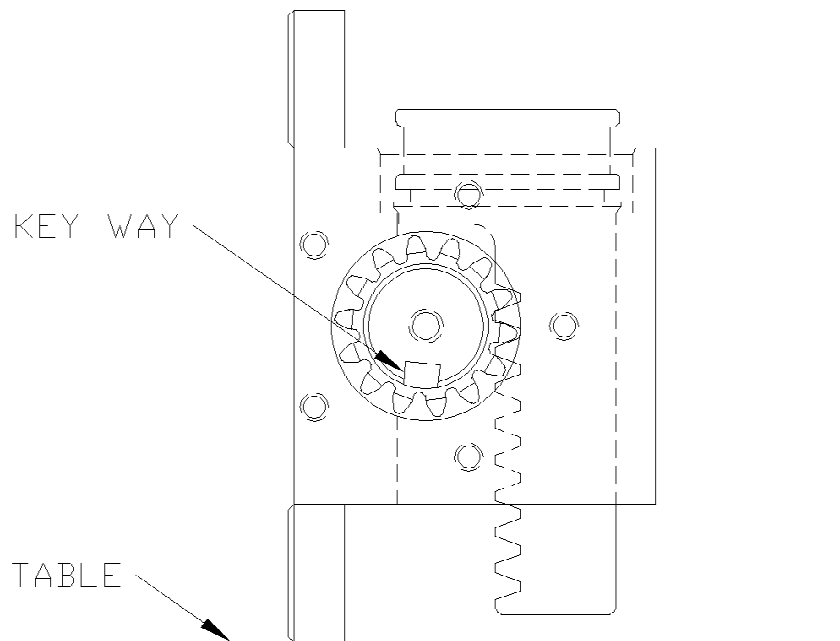

figure A-6

7. Coat one end of the actuator tubes (3) (fig. A-13) around the seal area with STP Oil Treatment as shown in figure A-7. Using a rubber mallet, drive the coated end of the tube onto the exposed rack until the tube end seats in the actuator body, making sure that the seals remain in place as the tube enters the counter-bore. Repeat this procedure for the other side.

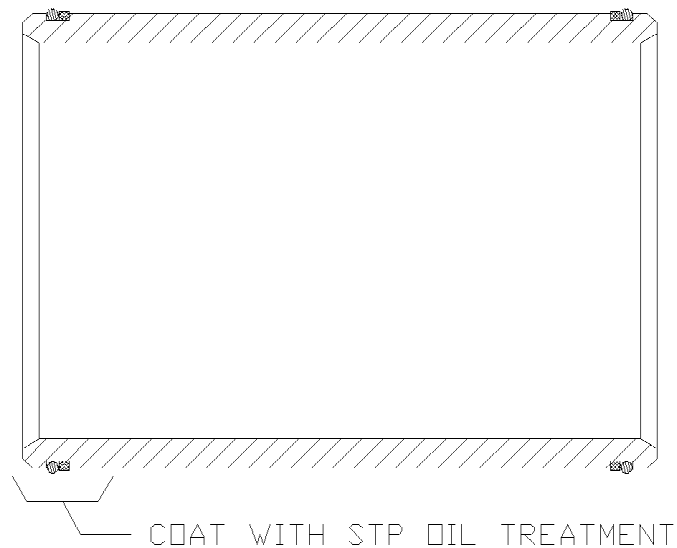
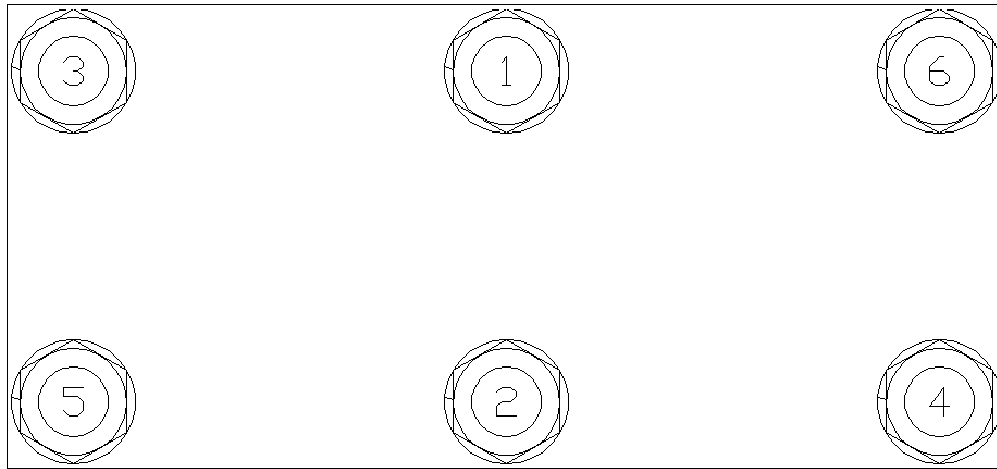

figure A-7

8. Install the six tie rod studs (6) (fig. A-13) by screwing the short threaded end into the actuator body. Hand tighten only at this time (the torque needed will be applied later in the procedure).
9. Place the tube cap (4) (fig. A-13) on the table. Coat the sides of the two bores in the tube cap with STP Oil Treatment. Install the cap over the tubes and rod studs with the oil port positioned to the left as shown in figure A-13. Using a rubber mallet, tap the tube cap over the tubes until the tubes seat in the cap, making sure that the seals remain in place.
10. Place the tube mounting bracket (30) (fig. A-13) over the two end rod studs opposite the oil port in the tube cap as shown in figure A-13.
11. Install the hex nuts (23) (fig. A-13) and lock washers (24) on the tie rod studs. Torque the nuts to 50 ft-lb. in the sequence shown in figure A-8.



TUBE CAP TORQUE SEQUENCE

figure A-8

12. Place the rack cap (5) (fig. A-13) bore side up on the table and coat the edge of each bore with STP Oil Treatment. Install the rack cap seals (14) (fig. A-9) in the rack cap.

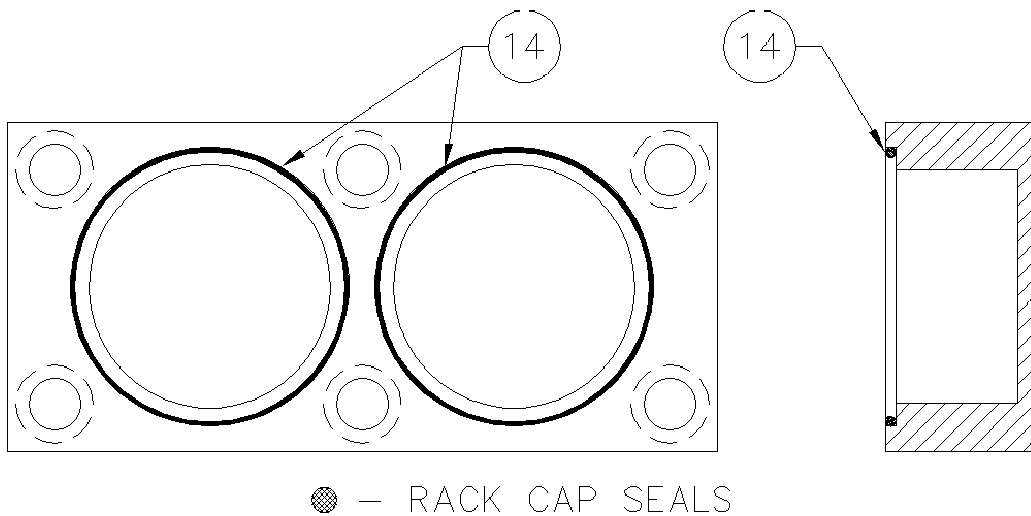
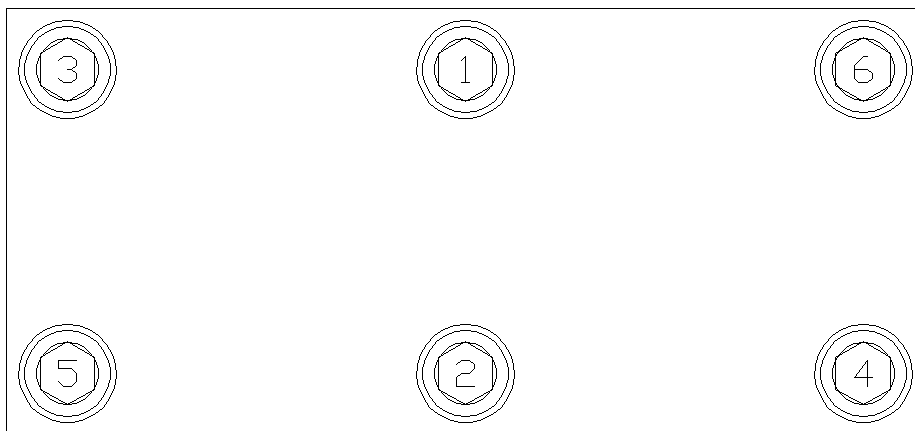

figure A-9

13. Reposition the actuator on the table mounting flanges down, and the lower tubes facing away from the assembler. Rotate the pinion shaft to allow 1" of the rack to protrude from the top of the actuator body. Install the rack cap with the oil port positioned to the left hand side of the actuator opposite the bottom oil port located in the tube cap as shown in figure A-13. Attach the rack cap to the actuator body using the socket head bolts (22) (fig. A-13) and lock washers (26). Torque the bolts to 90 ft-lb. in the sequence shown in figure A-10.



RACK CAP TORQUE SEQUENCE

figure A-10

14. Reposition the actuator so that the pinion shaft can be rotated with no obstacles. Rotate the pinion shaft to ensure that the racks move freely. Also make sure that the key ways point perfectly straight "up" toward the rack cap and "down" toward the tube cap at each end of the 180° stroke. If the assembly does not perform all of these functions correctly, it must be disassembled, cleaned, and reassembled.

15. Re-center the actuator pinion in the actuator body by tapping on one end of the shaft with a rubber mallet. Install the roller bearing (9) (fig. A-13), over the pinion shaft and inner race, and into the actuator body. Repeat this procedure for the other bearing.
16. Thoroughly clean the bearing caps (8) (fig. A-11) with a mild solvent and lubricate all seal grooves with STP oil treatment. Place the bearing caps (8) on the table (mounting surface down) and install the wiper ring (19) in the outside groove using a rubber mallet or small press. *(Avoid using tools that may damage seals or scratch bearing cap or bearing surfaces.)* Turn the bearing cap (8) over. Collapse the pinion seal (20) and carefully work it into the groove. Use fingers to carefully press the seal completely into the groove as shown in figure A-11. ***Be careful not to score or scratch the sealing surface during the installation.*** Install the bearing cap seal (15) and thrust washer (32) into their respective grooves on the bearing cap mounting surface as shown in figure A-11.
17. Coat the bearing cap seal area and pinion seal area shown in figure A-11 lightly with STP Oil Treatment.

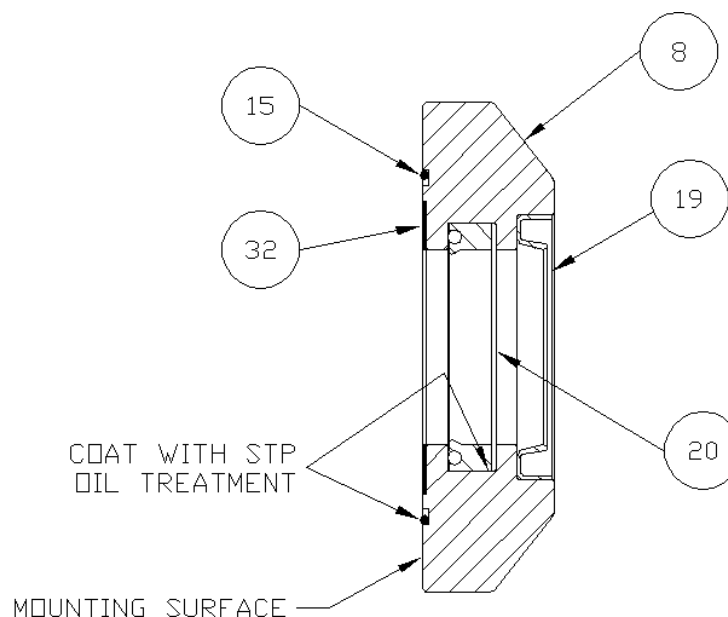

figure A-11

18. Wrap masking tape or electrical tape around the pinion to cover the edges at the keyway. Slide the bearing cap assembly over the pinion shaft with the bearing cap seal facing toward the actuator body and the flat surface of the flange shown in figure A-12 facing toward the actuator mounting flanges. Press against the bearing cap until the shoulder seats against the actuator body, making sure that the seals remain in place. Install the bearing cap bolts (21) (fig. A-13) and lock washers (25). Hand tighten only at this time. Repeat this procedure for other bearing cap.

19. After both bearing caps have been installed, torque all bearing cap bolts to 30 ft-lb. in the sequence shown in figure A-12.

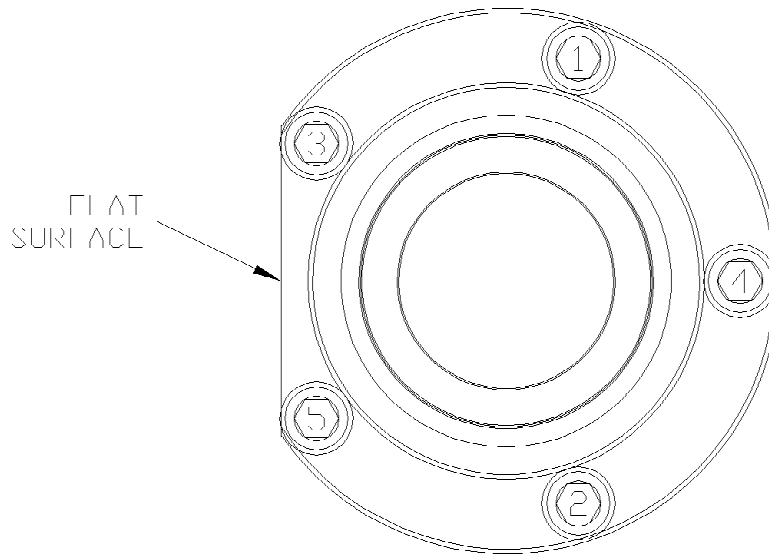

figure A-12

20. Install the 90° fitting (27) (fig. A-13) into the oil port on the side of the rack cap (5). Hand tighten only at this time.
21. Install the 45° bulk-head fitting (31) (fig. A-13) up through the hole in the tube mounting bracket (30) bolted to the tube cap as shown in figure A-13. The 45° end must be pointing down away from the rack cap (5) and back toward the mounting flanges on the actuator body. Hand tighten only at this time.
22. Install the rack cap extension tube assembly (29) (fig. A-13) between the 90° fitting in the rack cap and the 45° fitting in the tube mounting bracket as shown in figure A-13. Tighten all connections.
23. Install the orifice plug (11) (fig. A-13) into the oil port on the side of the tube cap (4), and install the 90° fitting (27) into the oil port over the orifice plug as shown in figure A-13. Turn the fitting so that it points down away from the rack cap (5) and back toward the mounting flanges on the actuator body and tighten.
24. Install the cap nuts (28) (fig. A-13) onto the open fittings to prevent contamination of the unit until the hoses are installed.
25. Install the actuator cover plate (33) (fig. A-13) onto the rack cap (5) using the cover plate bolts (34). Be sure to use *LOCTITE THREADLOCKER 242* on the cover plate bolts.

ACTUATOR ASSEMBLY

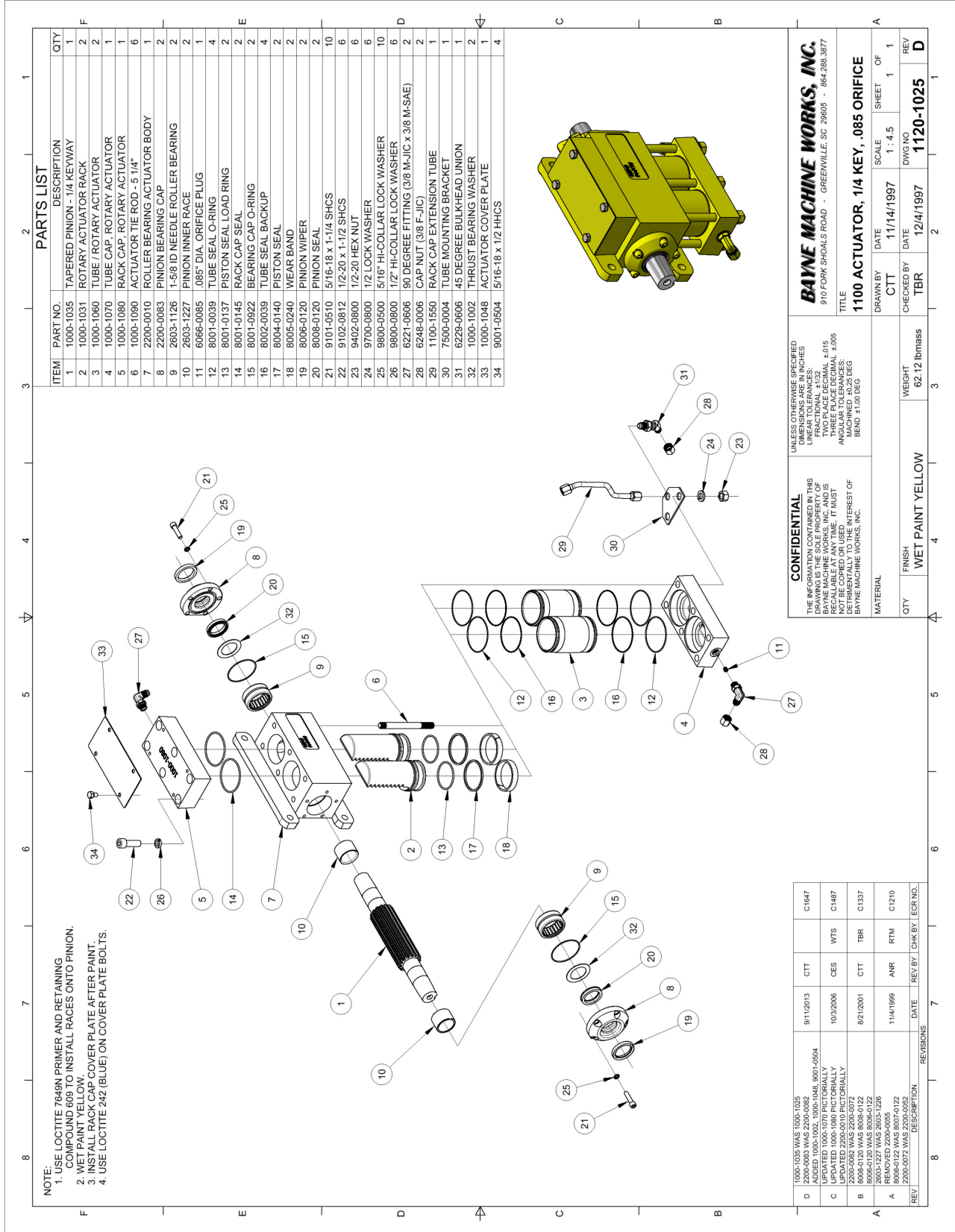

figure A-13

TROUBLE-SHOOTING CHART (WI-0046)

<i>SYMPTOM</i>	<i>POSSIBLE CAUSES</i>	<i>CORRECTIVE ACTION</i>
Lifter operation very erratic.	<ol style="list-style-type: none"> 1. Air trapped in system. 2. Low oil level. 	<ol style="list-style-type: none"> 1. Bleed all air from lifter hydraulic system. 2. Add oil to system.
Cart lifter will not pick up carts.	<ol style="list-style-type: none"> 1. Cart overweight. 2. Lifter system hydraulic pressure too low. 3. Truck system hydraulic pressure too low. 4. Faulty hand valve. 	<ol style="list-style-type: none"> 1. Reduce loaded weight of cart. 2. Check and adjust pressure relief on hand valve and lifter circuit relief in diverter valve. 3. Check and adjust pressure on truck system relief and full system relief in diverter valve. 4. Replace hand valve.
Lifter operates extremely slow.	<ol style="list-style-type: none"> 1. Engine idle too low. 2. Faulty hand valve. 3. Faulty truck hydraulic pump. 4. Trash in diverter valve. 5. Orifice in diverter valve is too small. 	<ol style="list-style-type: none"> 1. Adjust engine idle. 2. Replace hand valve. 3. Consult truck maintenance manual. 4. Remove orifice from diverter valve body and clean thoroughly. 5. Remove orifice from diverter valve body and increase diameter.
Lifter operates under recommended cycle time.	<ol style="list-style-type: none"> 1. Engine idle too high. 2. Orifice in diverter valve is too large. 	<ol style="list-style-type: none"> 1. Adjust engine idle. 2. Remove orifice from diverter valve body and replace with a smaller diameter.

TROUBLE-SHOOTING CHART (WI-0046)

<i>SYMPTOM</i>	<i>POSSIBLE CAUSES</i>	<i>CORRECTIVE ACTION</i>
Hydraulic components downstream of diverter valve not operating or operating extremely slow.	<ol style="list-style-type: none"> 1. Truck system hydraulic pressure too low. 2. Faulty full system relief valve cartridge in diverter valve. 3. Faulty truck system relief valve. 4. System flow is being restricted. 5. Trash in flow regulator cartridge. 	<ol style="list-style-type: none"> 1. Check and adjust pressure on truck system relief and full system relief in diverter valve. 2. Replace full system relief valve cartridge in diverter valve. 3. Consult truck maintenance manual. 4. Ensure there is proper flow throughout the hydraulic system. Remove any restrictions. 5. Remove flow regulator cartridge from diverter valve body and clean thoroughly.
Diverter valve leaking oil around cartridges.	<ol style="list-style-type: none"> 1. Worn or damaged seals on cartridge valves. 	<ol style="list-style-type: none"> 1. Install diverter valve seal kit.
Hand valve lever sticks in up or down position.	<ol style="list-style-type: none"> 1. Worn or broken spring center device. 2. Trash in or around hand valve shift spool. 3. Pressure (IN) and tank (OUT) ports are hooked up backwards. 	<ol style="list-style-type: none"> 1. Install spring center kit. 2. Disassemble and clean spool and housing. 3. Make sure all hoses are plumbed according to the hydraulic schematic.
Hand valve leaking oil around shift spool.	<ol style="list-style-type: none"> 1. Worn or damaged seals. 2. Worn spool. 	<ol style="list-style-type: none"> 1. Install hand valve seal kit. 2. Replace hand valve.

TROUBLE-SHOOTING CHART (WI-0046)

<i>SYMPTOM</i>	<i>POSSIBLE CAUSES</i>	<i>CORRECTIVE ACTION</i>
Actuator leaking oil around pinion shaft.	1. Worn pinion shaft seals.	1. Install pinion seal kit.
Actuator leaking oil around piston tubes or rack cap.	1. Worn seals in actuator.	1. Install actuator seal kit.
Lower hook connecting rods frequently breaking or bending.	1. Saddle to hook dimension out of adjustment. 2. Bars on carts are not standard spread dimensions.	1. Adjust saddle to hook dimension as described in the Operation Instructions of this manual. 2. Re-adjust saddle to hook dimension for these carts.
Lifter looses cart when dumping.	1. Saddle to hook dimension out of adjustment. 2. Lift bars on cart are bent or spread apart.	1. Adjust saddle to hook dimension as described in the Operation Instructions of this manual. 2. Replace cart or install new bars.
Lift bars on cart are being spread apart or damaged.	1. Saddle to hook dimension out of adjustment.	1. Adjust saddle to hook dimension as described in the Operation Instructions of this manual.

APPENDIX A
Assembly drawings and part numbers

ITEM NO	PART NO.	DESCRIPTION	QTY
1	1120-1025	1100 SERIES ROLLER BEARING ACTUATOR	1
2	2000-1101	21" STANDARD MAINFRAME	1
3	2024-1201	24" TORQUE ARM (R.H.)	1
4	2024-1205	24" TORQUE ARM (L.H.)	1
5	2000-1230	TORQUE BEARING ASSEMBLY	2
6	7500-0117	TORQUE ARM WASHER	2
7	7300-0410	KEY (1/4" x 1 3/16" LG.)	2
8	2024-1301	24" IDLER ARM (R.H.)	1
9	2024-1305	24" IDLER ARM (L.H.)	1
10	2000-1338	LOWER IDLER BEARING ASSEMBLY	2
11	2000-1335	UPPER IDLER BEARING ASSEMBLY	2
12	7500-0171	ARM WASHER	4
13	2000-1500	TL FACE PLATE	1
14	2000-3900	SADDLE	1
15	5000-0010	WARNING LABEL	1
16	5000-0060	NOTICE LABEL	1
17	7500-0070	MODEL/SERIAL NAME PLATE	1
18	7500-0071	DRIVE SCREW	4
19	2000-1400	HOOK	2
20	2000-1450	HOOK LINKAGE	1
21	2000-1470	HOOK SHAFT	1
22	7500-0006	ROD END SPACER	2
23	7202-0800	SPHERICAL ROD END	4
24	9001-0608	3/8-16 x 1" H.H.C.S.	21
25	9002-0608	3/8-24 x 1" H.H.C.S.	2
26	9401-0600	3/8-16 HEX NUT	3
27	9600-0500	5/16" FLAT WASHER	16
28	9700-0600	3/8" LOCK WASHER	21
29	9001-0808	1/2-13 x 1" H.H.C.S.	2
30	9001-0812	1/2-13 x 1 1/2" H.H.C.S.	2
31	9002-0816	1/2-20 x 2" H.H.C.S.	2
32	9402-0800	1/2-20 HEX NUT	8
33	9502-0800	1/2-20 HALF NUT	8
34	9600-0800	1/2" FLAT WASHER	4
35	9700-0800	1/2" LOCK WASHER	12

ITEM NO	PART NO.	DESCRIPTION	QTY
36	9902-0814	1/2-20 x 1 3/4" THREADED STUD	4
37	9902-0824	1/2-20 x 3" THREADED STUD	4
38	9902-0830	1/2-20 x 3 3/4" THREADED STUD	4
39	9201-0808	1/2-13 x 1" B.H.C.S.	2
40	9201-1010	5/8-11 x 1 1/4" B.H.C.S.	2
41	9600-1000	5/8" FLAT WASHER	2
42	5000-0015	BAYNE LOGO LABEL	1

NOTE:

- XX FIGURE ABOVE LINE INDICATES ITEM NO.
XX FIGURE BELOW LINE INDICATES QTY. REQD.
- USE LOCTITE #242 (BLUE) P/N 7500-0055 ON ALL THREADED FASTENERS UNLESS OTHERWISE NOTED.
- USE LOCTITE #271 (RED) P/N 7500-0057.

REV. LET.	REVISIONS	DATE	REV. BY	CHK. BY	IND.
E	5000-0060 WAS 5000-0020 ADDED 5000-0015	05/13/10	CTT		C1565
D	UPDATED 2000-1101 PICTORIALY	11/11/02	CTT	TJT	C1317
C	7500-0500 WAS 9600-0600 UPDATED 2000-1335 PICTORIALY	05/30/01	TBR	ANR	C1302
B	2000-1230 WAS 2000-1220 2000-1338 WAS 2000-1330 2000-1335 WAS 2000-1325 ADDED 7500-0171 & 9600-0600 REMOVED 7002-0400	04/10/00	ANR	RTM	C1251
A	RODATE HOOK LINKAGE	12/02/98	ANR	RTM	C1136

CONFIDENTIAL

This drawing is private and confidential communication and the property of BAYNE MACHINE WORKS, INC., Greenville, S.C. It MUST NOT be copied or lent without consent of BAYNE MACHINE WORKS, INC., and must be promptly returned with tender and/or completion of order to the purchasing department.

BAYNE MACHINE WORKS, INC.
 910 FORK SHOALS ROAD - GREENVILLE, SC 29605 - 864.288.3577

TOLERANCES IF NOT NOTED:
 0.000 ±0.005 - 0.000 ±0.015
 0/0 ±1/32 - ANGULAR ±0.25

SCALE: 1=2

SHEET 1 OF 3

REV. 1 E

CHKD BY: RTM

DATE: 04/17/98

TITLE: TL 1124 LIFTER ASSEMBLY

DWG. NO.: 1900-0021

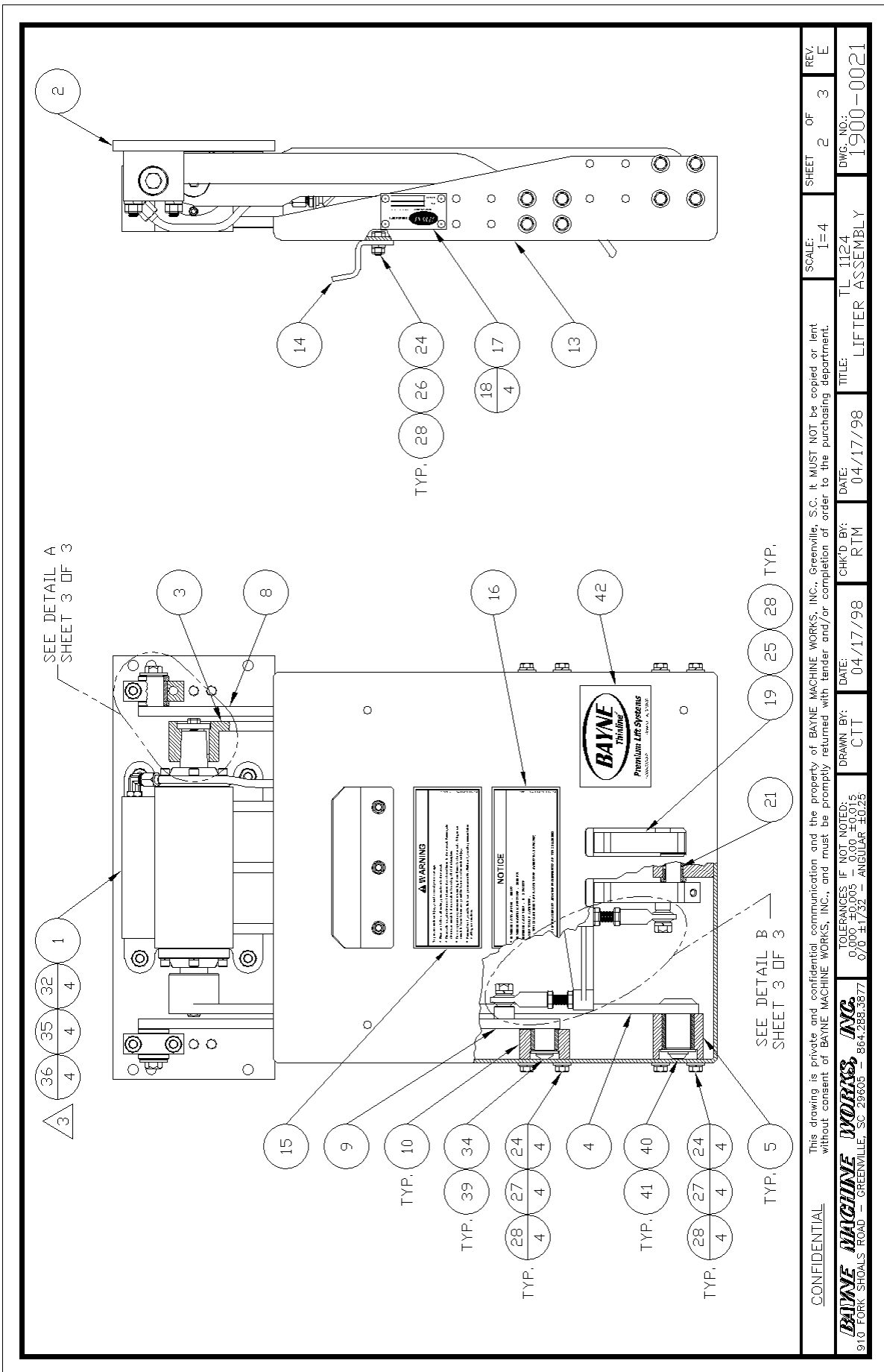

SCALE: 1=4 SHEET 2 OF 3 REV. E

DATE: 04/17/98 CHK'D BY: RIM TITLE: TL 1124 DWG. NO.: 1900-0021

CONFIDENTIAL

This drawing is private and confidential communication and the property of BAYNE MACHINE WORKS, INC., Greenville, S.C. It MUST NOT be copied or lent without consent of BAYNE MACHINE WORKS, INC., and must be promptly returned with tender and/or completion of order to the purchasing department.

BAYNE MACHINE WORKS, INC.
 910 FORK SHOALS ROAD - GREENVILLE, SC 29605 - 864.288.3577

TOLERANCES IF NOT NOTED:
 0.000 ±0.005 - 0.000 ±0.015
 0/0 ±1/32 - ANGULAR ±0.25

DRAWN BY: CTT DATE: 04/17/98

DATE: 04/17/98

DATE: 04/17/98

DATE: 04/17/98

DATE: 04/17/98

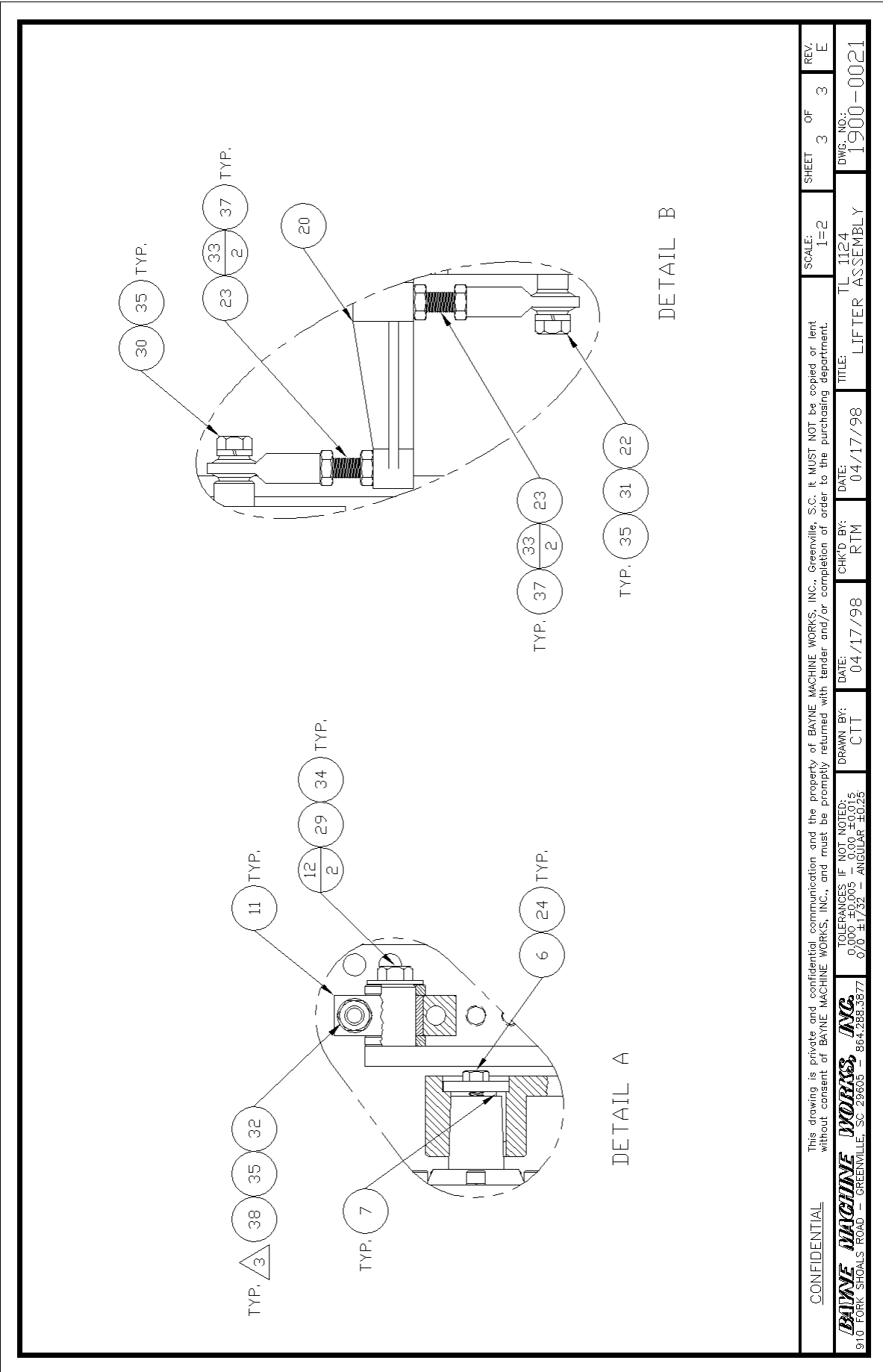

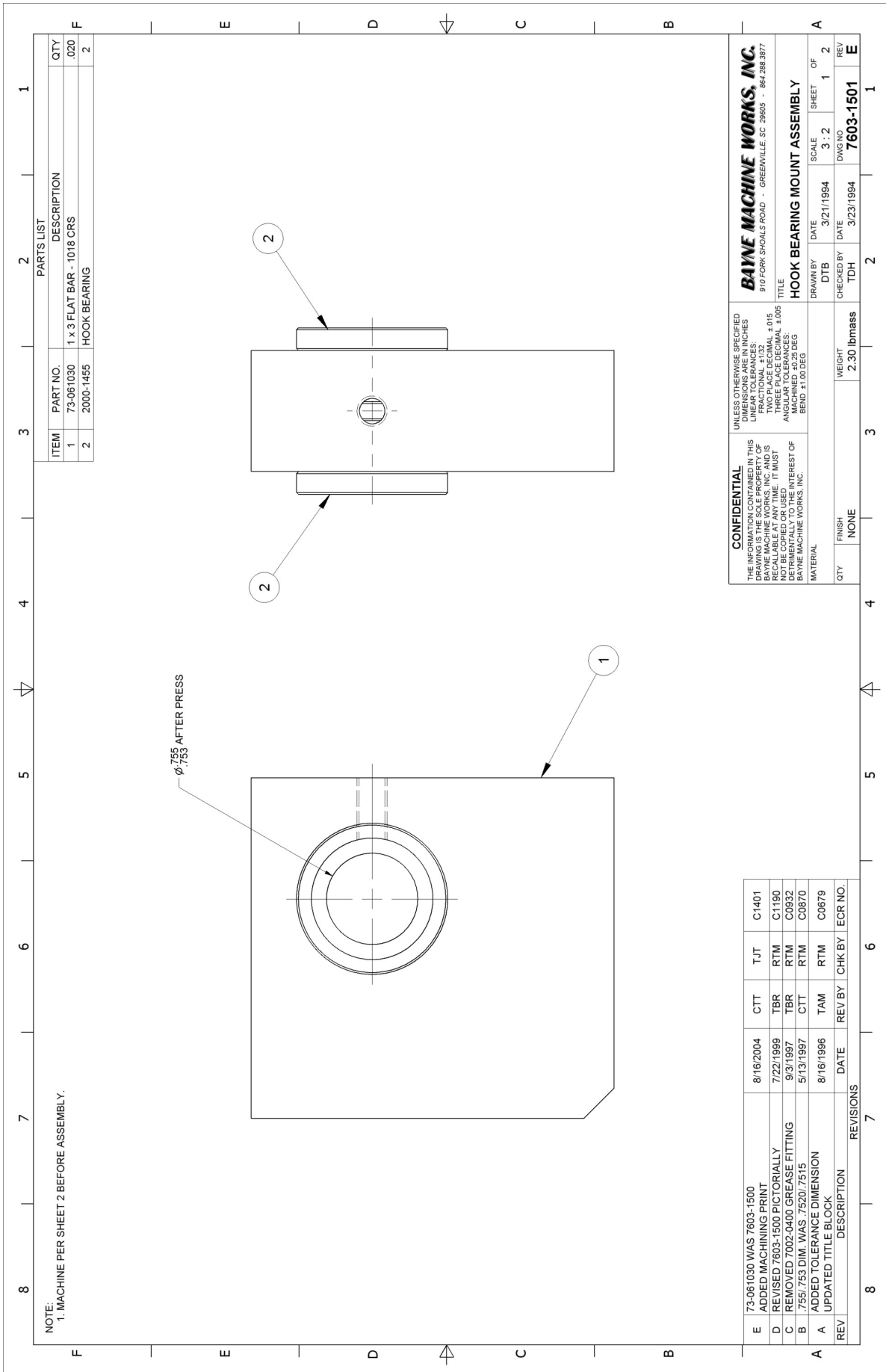

NOTE:
1. MACHINE PER SHEET 2 BEFORE ASSEMBLY.

PARTS LIST			
ITEM	PART NO.	DESCRIPTION	QTY
1	73-061030	1 X 3 FLAT BAR - 1018 CRS	.020
2	2000-1455	HOOK BEARING	2

<p>CONFIDENTIAL</p> <p>THE INFORMATION CONTAINED IN THIS DRAWING IS THE SOLE PROPERTY OF BAYNE MACHINE WORKS, INC. AND IS NOT TO BE REPRODUCED OR TRANSMITTED IN ANY FORM OR BY ANY MEANS, ELECTRONIC OR MECHANICAL, INCLUDING PHOTOCOPYING, RECORDING, OR BY ANY INFORMATION STORAGE AND RETRIEVAL SYSTEM. ANY UNAUTHORIZED USE OF THIS DRAWING IS STRICTLY PROHIBITED AND WILL BE DEEMED TO BE A VIOLATION OF THE PATENT RIGHTS OF BAYNE MACHINE WORKS, INC.</p>		<p>UNLESS OTHERWISE SPECIFIED DIMENSIONS ARE IN INCHES FRACTIONAL ± 1/32 TWO PLACE DECIMAL ± 0.015 THREE PLACE DECIMAL ± 0.005 ANGULAR TOLERANCES MACHINED ± 0.25 DEG BEND ± 1.00 DEG</p>	
<p>BAYNE MACHINE WORKS, INC. 910 FORK SHOALS ROAD - GREENVILLE, SC 29605 - 864-298-3977</p>		<p>HOOK BEARING MOUNT ASSEMBLY</p>	
<p>DATE: 3/21/1994</p>	<p>SCALE: 3 : 2</p>	<p>SHEET: 1</p>	<p>OF: 2</p>
<p>DRAWN BY: DTB</p>	<p>CHECKED BY: TDH</p>	<p>DWG NO: 7603-1501</p>	<p>REV: E</p>
<p>DATE: 3/23/1994</p>	<p>WEIGHT: 2.30 lbmss</p>	<p>3</p>	<p>2</p>

REV	DESCRIPTION	DATE	REV BY	CHK BY	ECR NO.
E	73-061030 WAS 7603-1500 ADDED MACHINING PRINT	8/16/2004	CTT	TJT	C1401
D	REVISED 7603-1500 PICTORIALY	7/22/1999	TBR	RTM	C1190
C	REMOVED 7002-0400 GREASE FITTING	9/3/1997	TBR	RTM	C0932
B	.755/.753 DIM. WAS .7520/.7515	5/13/1997	CTT	RTM	C0870
A	ADDED TOLERANCE DIMENSION	8/16/1996	TAM	RTM	C0679
	UPDATED TITLE BLOCK				

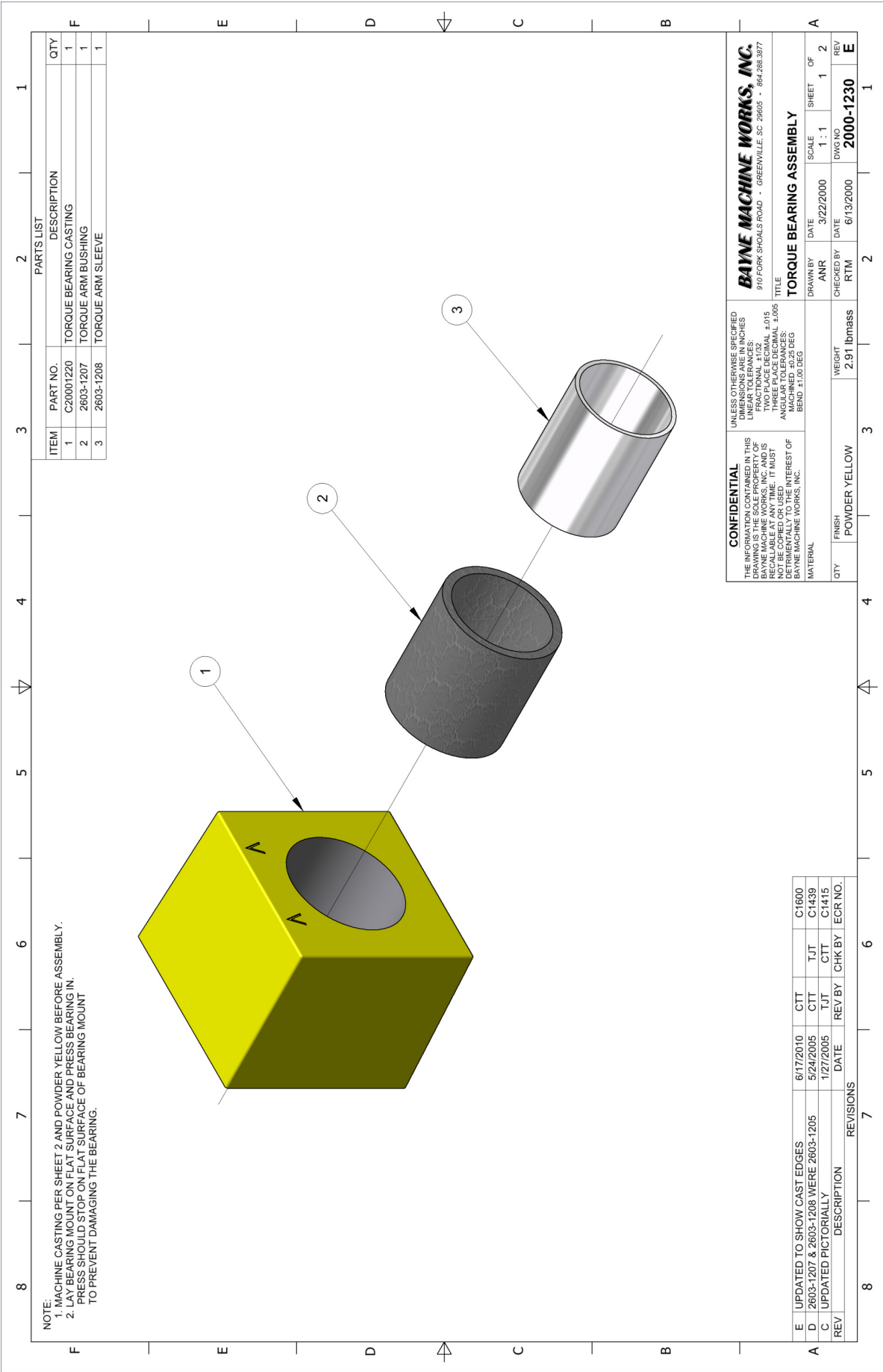

NOTE:
 1. MACHINE CASTING PER SHEET 2 AND POWDER YELLOW BEFORE ASSEMBLY.
 2. LAY BEARING MOUNT ON FLAT SURFACE AND PRESS BEARING IN.
 PRESS SHOULD STOP ON FLAT SURFACE OF BEARING MOUNT
 TO PREVENT DAMAGING THE BEARING.

PARTS LIST			
ITEM	PART NO.	DESCRIPTION	QTY
1	C20001220	TORQUE BEARING CASTING	1
2	2603-1207	TORQUE ARM BUSHING	1
3	2603-1208	TORQUE ARM SLEEVE	1

CONFIDENTIAL
 THE INFORMATION CONTAINED IN THIS DRAWING IS THE SOLE PROPERTY OF BAYNE MACHINE WORKS, INC. AND IS NOT TO BE REPRODUCED OR TRANSMITTED IN ANY FORM OR BY ANY MEANS, ELECTRONIC OR MECHANICAL, INCLUDING PHOTOCOPYING, RECORDING, OR BY ANY INFORMATION STORAGE AND RETRIEVAL SYSTEM. ANY UNAUTHORIZED USE, REPRODUCTION, OR TRANSMISSION OF THIS DRAWING IS STRICTLY PROHIBITED AND WILL BE DEEMED TO BE A VIOLATION OF THE PATENT RIGHTS OF BAYNE MACHINE WORKS, INC. IN THE EVENT OF A VIOLATION, THE USER SHALL BE RESPONSIBLE FOR ALL DAMAGES AND COSTS INCURRED BY BAYNE MACHINE WORKS, INC. IN THE EVENT OF A VIOLATION.

UNLESS OTHERWISE SPECIFIED DIMENSIONS ARE IN INCHES
 DECIMALS TO TWO PLACES
 FRACTIONAL $\pm 1/32$
 TWO PLACE DECIMAL ± 0.015
 ANGULAR DIMENSIONS ± 0.005
 ANGULAR TOLERANCES MACHINED ± 0.25 DEG
 BEND ± 1.00 DEG

BAYNE MACHINE WORKS, INC.
 910 FORK SHOALS ROAD - GREENVILLE, SC 29605 - 864.298.3977

TORQUE BEARING ASSEMBLY

DATE	3/22/2000	SCALE	1:1	SHEET	1	OF	2
DRAWN BY	ANR	CHECKED BY	RTM	DWG NO	2000-1230		
DATE	6/13/2000	REV	E				

MATERIAL: POWDER YELLOW
 WEIGHT: 2.91 lbmass

REV	DESCRIPTION	DATE	REV BY	CHK BY	ECR NO.
E	UPDATED TO SHOW CAST EDGES	6/17/2010	CTT	TJT	C1600
D	2603-1207 & 2603-1208 WERE 2603-1205	5/24/2005	CTT	TJT	C1439
C	UPDATED PICTORIALY	1/27/2005	TJT	CTT	C1415

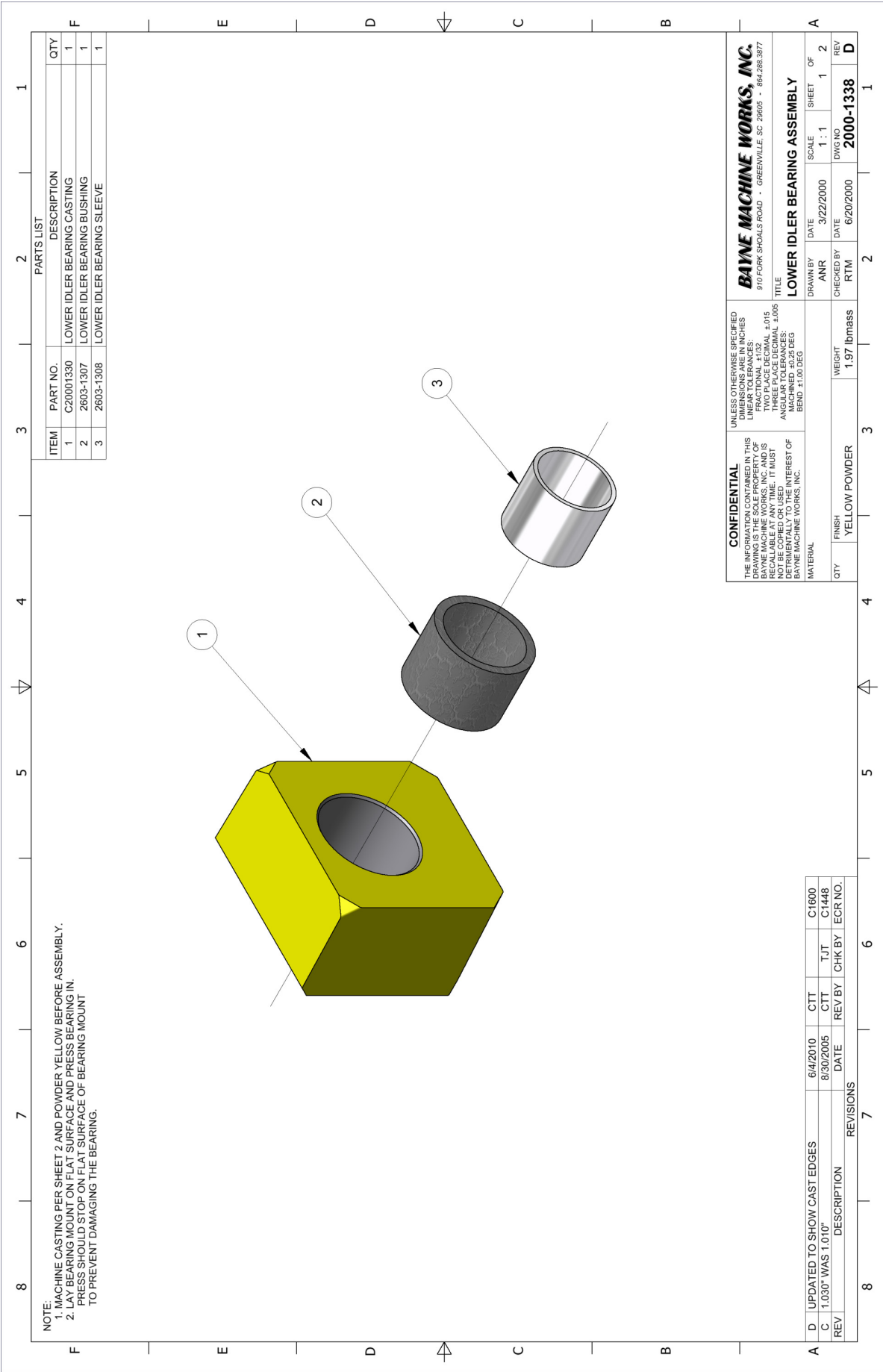

NOTE:
 1. MACHINE CASTING PER SHEET 2 AND POWDER YELLOW BEFORE ASSEMBLY.
 2. LAY BEARING MOUNT ON FLAT SURFACE AND PRESS BEARING IN.
 PRESS SHOULD STOP ON FLAT SURFACE OF BEARING MOUNT
 TO PREVENT DAMAGING THE BEARING.

PARTS LIST			
ITEM	PART NO.	DESCRIPTION	QTY
1	C20001330	LOWER IDLER BEARING CASTING	1
2	2603-1307	LOWER IDLER BEARING BUSHING	1
3	2603-1308	LOWER IDLER BEARING SLEEVE	1

CONFIDENTIAL		UNLESS OTHERWISE SPECIFIED DIMENSIONS ARE IN INCHES TWO PLACE DECIMAL ±.015 FRACTIONAL ±1/32	
THE INFORMATION CONTAINED IN THIS DRAWING IS THE SOLE PROPERTY OF BAYNE MACHINE WORKS, INC. AND IS NOT TO BE REPRODUCED OR TRANSMITTED IN ANY FORM OR BY ANY MEANS, ELECTRONIC OR MECHANICAL, INCLUDING PHOTOCOPYING, RECORDING, OR BY ANY INFORMATION STORAGE AND RETRIEVAL SYSTEM, WITHOUT THE WRITTEN CONSENT OF BAYNE MACHINE WORKS, INC.		TITLE LOWER IDLER BEARING ASSEMBLY	
MATERIAL YELLOW POWDER		WEIGHT 1.97 lbmass	SCALE 1:1
QTY	FINISH	DATE	SHEET OF
		3/22/2000	1 1
		6/20/2000	2 2
			DWG NO 2000-1338
			REV D

REV	DESCRIPTION	DATE	REV BY	CHK BY	ECR NO.
D	UPDATED TO SHOW CAST EDGES	6/4/2010	CTT	TJT	C1600
C	1.030" WAS 1.010"	8/30/2005	CTT	TJT	C1448

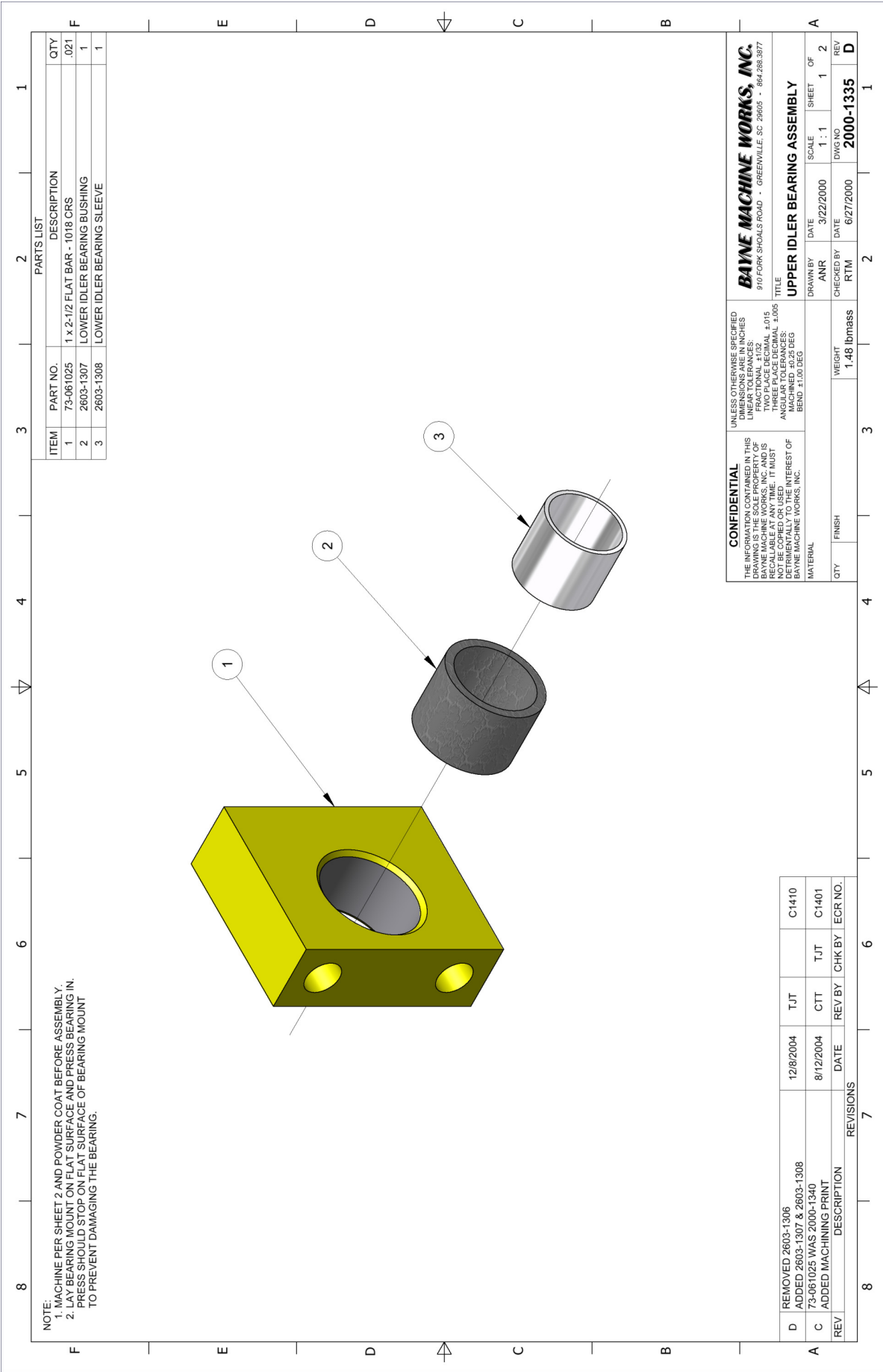

NOTE:
 1. MACHINE PER SHEET 2 AND POWDER COAT BEFORE ASSEMBLY.
 2. BUSHING MOUNT ON FLAT SURFACE AND PRESS BEARING IN.
 3. PRESS SHOULD STOP ON THE SURFACE OF BEARING MOUNT TO PREVENT DAMAGING THE BEARING.

PARTS LIST			
ITEM	PART NO.	DESCRIPTION	QTY
1	73-061025	1 x 2-1/2 FLAT BAR - 1018 CRS	.021
2	2603-1307	LOWER IDLER BEARING BUSHING	1
3	2603-1308	LOWER IDLER BEARING SLEEVE	1

CONFIDENTIAL
 THE INFORMATION CONTAINED IN THIS DRAWING IS THE SOLE PROPERTY OF BAYNE MACHINE WORKS, INC. AND IS NOT TO BE REPRODUCED OR TRANSMITTED IN ANY FORM OR BY ANY MEANS, ELECTRONIC OR MECHANICAL, INCLUDING PHOTOCOPYING, RECORDING, OR BY ANY INFORMATION STORAGE AND RETRIEVAL SYSTEM. ANY UNAUTHORIZED USE OF THIS DRAWING IS STRICTLY PROHIBITED AND WILL BE DEEMED TO BE A VIOLATION OF THE PATENT RIGHTS OF BAYNE MACHINE WORKS, INC.

UNLESS OTHERWISE SPECIFIED DIMENSIONS ARE IN INCHES
 DECIMALS TO TWO PLACES
 FRACTIONAL 1/32
 TWO PLACE DECIMAL ±.015
 ANGULAR TO TOLERANCES ±.005
 MACHINED ±.025 DEG
 BEND ±1.00 DEG

BAYNE MACHINE WORKS, INC.
 910 FORK SHOALS ROAD - GREENVILLE, SC 29695 - 864.298.3977

TITLE: **UPPER IDLER BEARING ASSEMBLY**

DRAWN BY	ANR	DATE	3/22/2000	SCALE	1:1	SHEET	1	OF	2
CHECKED BY	RTM	DATE	6/27/2000	DWG NO	2000-1335		REV	D	

MATERIAL	QTY	FINISH	WEIGHT
			1.48 lbmass

REV	DESCRIPTION	DATE	REV BY	CHK BY	ECR NO.
D	REMOVED 2603-1306	12/8/2004	TJT		C1410
C	ADDED 2603-1307 & 2603-1308	8/12/2004	CTT	TJT	C1401
A	ADDED MACHINING PRINT				

REVISIONS

NOTE:

1. DIMENSIONS ACCOMMODATE ANSI Z245.60-2008 TYPE B CONTAINERS (DOMESTIC 2-BAR CARTS), BUT MAY VARY DUE TO CONTAINER SPECIFICATIONS OR APPLICATIONS.
2. ALL DIMENSIONS ARE APPROXIMATE.
3. UNITS MARKED WITH "*" HAVE A SLOW DOWN ACTUATOR.
4. FOR BOLT-ON APPLICATIONS USE MOUNTING PLATE KIT 2000-1112.
5. PART NUMBERS: SEE CHART

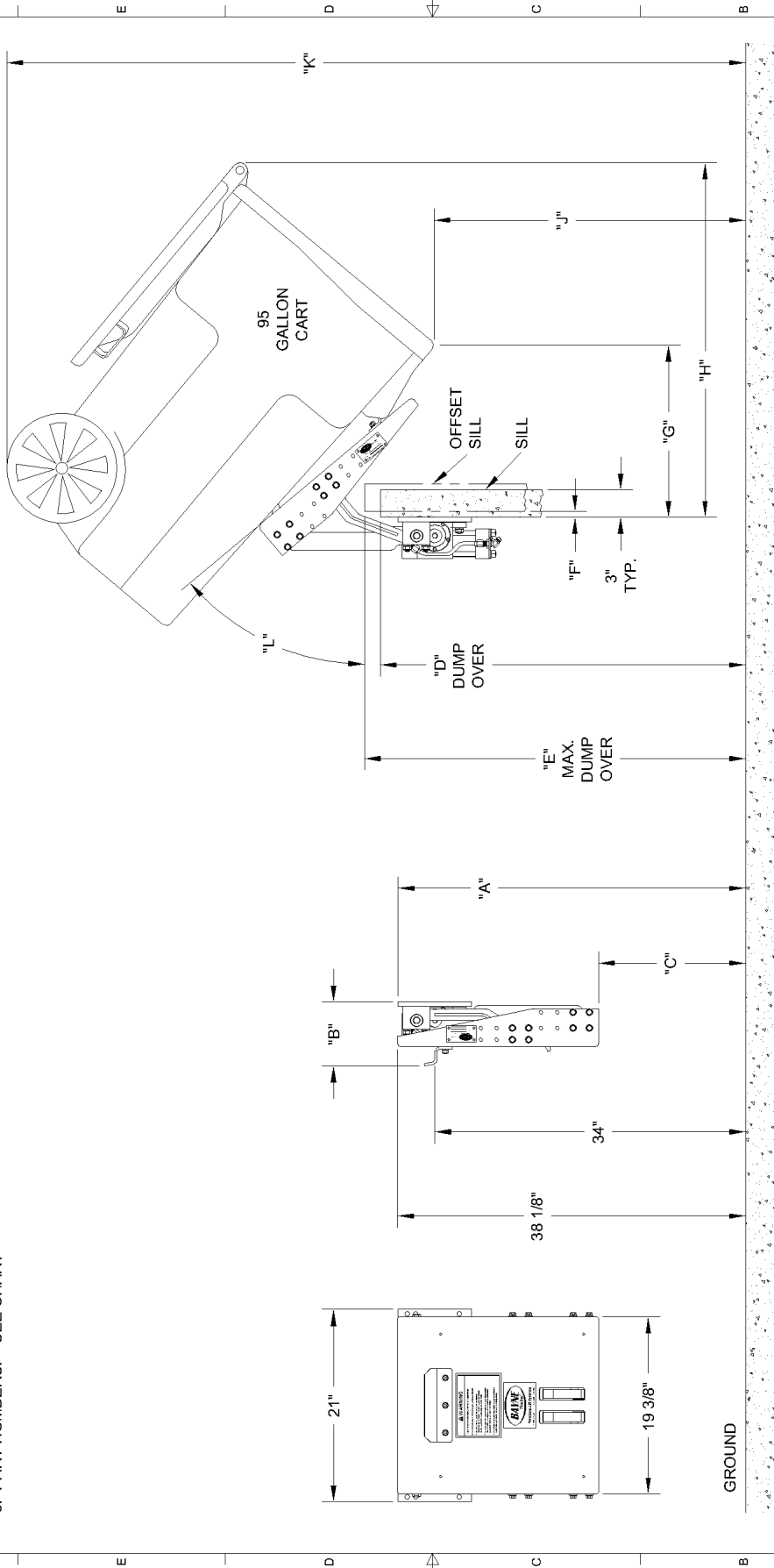

CONFIDENTIAL
 THE INFORMATION CONTAINED IN THIS DRAWING IS THE PROPERTY OF BAYNE MACHINE WORKS, INC. AND IS NOT BE COPIED OR REPRODUCED IN ANY MANNER WITHOUT THE WRITTEN CONSENT OF BAYNE MACHINE WORKS, INC.

UNLESS OTHERWISE SPECIFIED DIMENSIONS ARE IN INCHES
 LINEAR DIMENSIONS: FRACTIONS: TWO PLACE DECIMAL 0.015 THREE PLACE DECIMAL 0.005 ANGLES: DEGREES: 0.1 DEGREES BEND: 1:1.00 DEG

BAYNE MACHINE WORKS, INC.
 910 FORK SHOALS ROAD - GREENVILLE, SC 29605 - 864.288.3877

TITLE
 TL SERIES SPECIFICATIONS

DRAWN BY	DATE	SCALE	SHEET	OF
CTT	10/22/2009	NONE	1	4
CHECKED BY	DATE	DWG NO	REV	
		H3000027	-	

QTY	FINISH	WEIGHT

MODEL NUMBER	PART #	"A" DIM.	"B" DIM.	"C" DIM.	"D" DIM.	"E" DIM.	"F" DIM.	"G" DIM.	"H" DIM.	"J" DIM.	"K" DIM.	"L" DIM.
TL 1116	1900-0017	38"	7"	16 1/8"	40"	41 3/4"	5/8"	18 7/8"	38 3/4"	34 1/8"	80 3/4"	50°
TL 1116 F.L.B.	1900-3017											
TL 1116 (TOP HOLES)	1900-0250	41 1/2"	7"	16 1/8"	43 1/2"	45 3/4"	1"	16 5/8"	36 1/2"	40 1/4"	87"	50°
TL 2216 (TOP HOLES)**	1900-0228											
TL 1116-2524	1900-0033	38 3/8"	12 1/2"	16 1/4"	40 7/8"	43 1/8"	1 7/8"	21 1/8"	43 1/8"	32 3/8"	80 1/4"	56°
TL 2216-2524 **	1900-0237											
TL 1116-2524 (TOP HOLES)	1900-0170	41 7/8"	12 1/8"	16 1/4"	44 3/8"	46 3/4"	2 1/8"	19 1/8"	41 1/8"	38 3/4"	86 5/8"	56°
TL 2216-2524 (TOP HOLES)**	1900-0171											
TL 1116-2526	1900-0120	38"	13"	16 1/8"	40 1/4"	42 7/8"	2 1/4"	20 3/4"	44 7/8"	29 5/8"	78 3/8"	63°
TL 2216-2526 **	1900-0190											
TL 1116-2526 (TOP HOLES)	1900-0172	41 1/2"	13"	16 1/8"	43 3/4"	46 3/8"	2 1/4"	19 1/8"	43 3/8"	36 1/4"	85"	63°
TL 2216-2526 (TOP HOLES)**	1900-0173											
TL 1120	1900-0019											
TL 1120 F.L.B.	1900-3019	42"	7"	16 1/8"	45 3/8"	49 3/4"	1 1/4"	19 5/8"	38 1/2"	43 1/4"	89 1/8"	47°
TL 2220 **	1900-0023											
TL 1120 (TOP HOLES)	1900-0252	45 1/2"	7"	16 1/8"	48 7/8"	53 7/8"	1 1/2"	17 1/4"	36 1/8"	49 1/4"	95 1/4"	47°
TL 2220 (TOP HOLES)**	1900-0257											
TL 1120 (1/4" OFFSET IDLER)	1900-0166	42 3/8"	8 1/2"	16 1/4"	45 3/4"	49 3/4"	1 1/8"	19 1/8"	38 3/4"	42 7/8"	89 1/4"	49°
TL 1120-2524	1900-0119	42 3/8"	12 1/2"	16 1/4"	46 1/8"	51 1/8"	2 5/8"	22 1/4"	43"	41 3/4"	88 7/8"	52°
TL 2220-2524 **	1900-0138											
TL 1120-2524 (TOP HOLES)	1900-0167	45 7/8"	12 1/8"	16 1/4"	49 5/8"	54 7/8"	2 7/8"	20 1/8"	40 3/4"	48"	95 1/8"	52°
TL 2220-2524 (TOP HOLES)**	1900-0168											
TL 1120-2526	1900-0035	42 1/8"	13 3/8"	16 1/8"	45 1/2"	51"	3"	22 5/8"	45 1/8"	39 1/2"	87 5/8"	58°
TL 2220-2526 **	1900-0039											
TL 1120-2526 (TOP HOLES)	1900-0169	45 5/8"	13 1/4"	16 1/8"	49"	54 5/8"	3"	20 3/4"	43 1/4"	46"	94 1/8"	58°
TL 2220-2526 (TOP HOLES)**	1900-0174											

CONFIDENTIAL
 THE INFORMATION CONTAINED IN THIS DRAWING IS THE PROPERTY OF BAYNE MACHINE WORKS, INC. AND IS NOT TO BE REPRODUCED OR TRANSMITTED IN ANY FORM OR BY ANY MEANS, ELECTRONIC OR MECHANICAL, INCLUDING PHOTOCOPYING, RECORDING, OR BY ANY INFORMATION STORAGE AND RETRIEVAL SYSTEM. WITHOUT THE WRITTEN PERMISSION OF BAYNE MACHINE WORKS, INC.

UNLESS OTHERWISE SPECIFIED DIMENSIONS ARE IN INCHES
 DIMENSIONS IN PARENTHESES ARE FRACTIONS
 DIMENSIONS IN BRACKETS ARE DECIMALS
 TWO PLACE DECIMAL .0015
 THREE PLACE DECIMAL .0005
 ANGLES ARE TO BE MAINTAINED AS SHOWN
 UNLESS OTHERWISE SPECIFIED BEND .0100 DEG

BAYNE MACHINE WORKS, INC.
 930 FORK SHOALS ROAD - GREENVILLE, SC 29605 - 864.288.3877

TITLE: TL SERIES SPECIFICATIONS

DRAWN BY: CTT DATE: 10/22/2009 SCALE: NONE SHEET OF 4
 CHECKED BY: DATE: DWG NO: H3000027 REV: -

MODEL NUMBER	PART #	"A" DIM.	"B" DIM.	"C" DIM.	"D" DIM.	"E" DIM.	"F" DIM.	"G" DIM.	"H" DIM.	"J" DIM.	"K" DIM.	"L" DIM.
TL 1124	1900-0021											
TL 1124 **	1901-0021											
TL 1124 (.059" ORIFICE)	1900-0232	46"	7"	16 1/8"	50 1/8"	57 5/8"	1 5/8"	20"	38 1/4"	51 7/8"	97 3/8"	45°
TL 1124 (3/8" KEY)	1900-0176											
TL 1124 (3/8" KEY) (.059" ORIFICE)	1900-0276											
TL 2224 **	1900-0025											
TL 1124 (TOP HOLES)	1900-0177											
TL 1124 (TOP HOLES)**	1900-0254	49 1/2"	7"	16 1/8"	53 5/8"	61 3/4"	1 7/8"	17 5/8"	35 3/4"	57 7/8"	103 1/4"	45°
TL 1124 (TOP HOLES)(3/8" KEY)	1900-0221											
TL 2224 (TOP HOLES)**	1900-0259											
TL 1124 (1/4" OFFSET IDLER)	1900-0236	46 1/2"	8 1/2"	16 1/4"	50 1/2"	57 5/8"	1 1/2"	19 1/2"	38 1/2"	51 1/2"	97 1/2"	48°
TL 1124 (1/2" OFFSET IDLER)	1900-0240	46 7/8"	9 3/4"	16 1/2"	51"	57 1/2"	1 3/8"	19"	38 3/4"	51 1/8"	97 3/4"	49°
TL 1124-2524	1900-0137											
TL 1124-2524 **	1901-0022	46"	11"	16 1/8"	50 1/8"	58 1/4"	2 1/2"	22 1/4"	43"	49 3/8"	96 1/2"	52°
TL 2224-2524 **	1900-0139											
TL 1124-2524 (TOP HOLES)	1900-0178	49 1/2"	11"	16 1/8"	53 5/8"	62 1/4"	3 1/8"	20 1/8"	40 3/4"	55 5/8"	102 3/4"	52°
TL 2224-2524 (TOP HOLES)**	1900-0179											
TL 1124-2526	1900-0162											
TL 1124-2526 **	1900-0037	46"	13"	16 1/8"	50 1/2"	58 3/4"	3"	23 3/8"	45 1/8"	48 3/8"	96 1/8"	55°
TL 2224-2526 **	1900-0041											
TL 1124-2526 (TOP HOLES)	1900-0184	49 1/2"	13"	16 1/8"	54"	62 5/8"	3 3/8"	21 3/8"	43 1/8"	54 3/4"	102 3/8"	55°
TL 2224-2526 (TOP HOLES)**	1900-0185											

CONFIDENTIAL
 THE INFORMATION CONTAINED IN THIS DRAWING IS THE PROPERTY OF BAYNE MACHINE WORKS, INC. AND IS NOT TO BE REPRODUCED OR TRANSMITTED IN ANY FORM OR BY ANY MEANS, ELECTRONIC OR MECHANICAL, INCLUDING PHOTOCOPYING, RECORDING, OR BY ANY INFORMATION STORAGE AND RETRIEVAL SYSTEM. WITHOUT THE WRITTEN PERMISSION OF BAYNE MACHINE WORKS, INC.

UNLESS OTHERWISE SPECIFIED DIMENSIONS ARE IN INCHES
 DIMENSIONS IN PARENTHESES ARE FRACTIONS
 DIMENSIONS IN BRACKETS ARE DECIMALS
 TWO PLACE DECIMAL .0015
 THREE PLACE DECIMAL .0005
 ANGLES ARE TO NEAREST .01 DEGS
 MACHINED .0015 DEGS
 BEND .11.00 DEGS

BAYNE MACHINE WORKS, INC.
 910 FORK SHOALS ROAD - GREENVILLE, SC 29605 - 864.288.3877

TITLE: TL SERIES SPECIFICATIONS

DRAWN BY: CTT DATE: 10/22/2009 SCALE: NONE SHEET OF: 4
 CHECKED BY: DATE: DWG NO: H3000027 REV: -

MATERIAL: _____ WEIGHT: _____

QTY: _____ FINISH: _____

MODEL NUMBER	PART #	"A" DIM.	"B" DIM.	"C" DIM.	"D" DIM.	"E" DIM.	"F" DIM.	"G" DIM.	"H" DIM.	"J" DIM.	"K" DIM.	"L" DIM.
TL 1128 **	1900-0186	50"	7"	16 1/8"	54 5/8"	65 3/8"	2"	20 3/8"	38"	60 3/8"	105 3/8"	44°
TL 2228 **	1900-0027	53 1/2"	7"	16 1/8"	58 1/8"	69 5/8"	2 1/8"	17 7/8"	35 1/2"	66 1/4"	111 3/8"	44°
TL 2228-2524 **	1900-0121	50"	11"	16 1/8"	55 1/4"	66 1/8"	2 5/8"	22 7/8"	42 3/4"	58 1/8"	104 7/8"	50°
TL 1128-2524 (MID HOLES) **	1900-0274	51 3/4"	11"	16 1/8"	57"	68 1/4"	2 1/2"	21 3/4"	41 5/8"	61 1/4"	107 7/8"	50°
TL 2228-2524 (MID HOLES) **	1900-0275	53 1/2"	11"	16 1/8"	58 3/4"	70 1/8"	3 1/8"	20 5/8"	40 1/2"	64 3/8"	111"	50°
TL 2228-2524 (TOP HOLES) **	1900-0188	50 1/4"	13 7/8"	16 1/4"	56 3/8"	67 1/4"	3"	24 5/8"	44 7/8"	58"	104 7/8"	51°
TL 2228-2526 **	1900-0043	53 3/4"	13 3/4"	16 1/4"	59 7/8"	71 1/4"	3 5/8"	22 3/8"	42 5/8"	64 1/4"	111 1/8"	51°
TL 1132 **	1900-0277	54"	7"	16 1/8"	60 5/8"	73 1/4"	2"	20 1/2"	37 7/8"	68 3/4"	113 1/2"	43°
TL 2232 **	1900-0029	57 1/2"	7"	16 1/8"	64 1/8"	77 1/2"	2 1/8"	18 1/8"	35 1/4"	74 5/8"	119 3/8"	43°
TL 1132 (TOP HOLES) **	1900-0278	54"	11"	16 1/8"	60 3/8"	73 7/8"	2 5/8"	23 3/8"	42 5/8"	66 3/4"	113"	48°
TL 2232 (TOP HOLES) **	1900-0263	57 1/2"	11"	16 1/8"	63 7/8"	78"	3 1/8"	21"	40 1/4"	72 7/8"	119 1/8"	48°
TL 2232-2524 **	1900-0116	54"	13"	16 1/8"	60 5/8"	74 3/8"	2 7/8"	24 5/8"	44 7/8"	65 7/8"	112 3/4"	51°
TL 2232-2524 (TOP HOLES) **	1900-0270	57 1/2"	13"	16 1/8"	64 1/8"	78 1/2"	3 1/2"	22 1/2"	42 5/8"	72 1/8"	118 7/8"	51°
TL 2232-2526 **	1900-0045	56"	7"	16 1/8"	63 1/8"	77 1/8"	2 1/8"	20 5/8"	37 3/4"	72 7/8"	117 1/2"	43°
TL 2232-2526 (TOP HOLES) **	1900-0271	59 1/2"	7"	16 1/8"	66 5/8"	81 3/8"	2 1/8"	18"	35 1/4"	78 3/4"	123 3/8"	43°
TL 1134 **	1900-0279	56"	11"	16 1/8"	62 7/8"	77 3/4"	2 5/8"	23 1/2"	42 1/2"	71"	117 1/8"	48°
TL 2234 **	1900-0031	59 1/2"	11"	16 1/8"	66 3/8"	81 7/8"	3"	21 1/8"	40 1/8"	77 1/8"	123 1/8"	48°
TL 2234 (TOP HOLES) **	1900-0265	56 1/4"	13 7/8"	16 1/4"	64 1/8"	79"	2 7/8"	25 3/8"	44 5/8"	71"	117 1/4"	48°
TL 2234-2524 **	1900-0140	59 3/4"	13 3/4"	16 1/4"	67 5/8"	83"	3 1/2"	23"	42 1/4"	77 1/8"	123 3/8"	48°
TL 2234-2524 (TOP HOLES) **	1900-0272	56 1/4"	13 7/8"	16 1/4"	64 1/8"	79"	2 7/8"	25 3/8"	44 5/8"	71"	117 1/4"	48°
TL 2234-2526 **	1900-0117	59 3/4"	13 3/4"	16 1/4"	67 5/8"	83"	3 1/2"	23"	42 1/4"	77 1/8"	123 3/8"	48°
TL 2234-2526 (TOP HOLES) **	1900-0273	59 3/4"	13 3/4"	16 1/4"	67 5/8"	83"	3 1/2"	23"	42 1/4"	77 1/8"	123 3/8"	48°

CONFIDENTIAL
 THE INFORMATION CONTAINED IN THIS DRAWING IS THE PROPERTY OF BAYNE MACHINE WORKS, INC. AND IS NOT TO BE COPIED OR REPRODUCED IN ANY MANNER WITHOUT THE WRITTEN PERMISSION OF BAYNE MACHINE WORKS, INC.

UNLESS OTHERWISE SPECIFIED DIMENSIONS ARE IN INCHES
 DIMENSIONS IN PARENTHESES ARE FRACTIONS
 TWO PLACE DECIMAL .0015
 THREE PLACE DECIMAL .0005
 ANGLES UNLESS OTHERWISE SPECIFIED ARE TO BE MAINTAINED TO THE NEAREST 0.100 DEGREE

BAYNE MACHINE WORKS, INC.
 910 FORK SHOALS ROAD - GREENVILLE, SC 29605 - 864.288.3877

TITLE: TL SERIES SPECIFICATIONS

DRAWN BY: CTT DATE: 10/22/2009 SCALE: NONE SHEET OF 4
 CHECKED BY: DATE: DWG NO: H3000027 REV: -

QTY: FINISH: WEIGHT: MATERIAL:

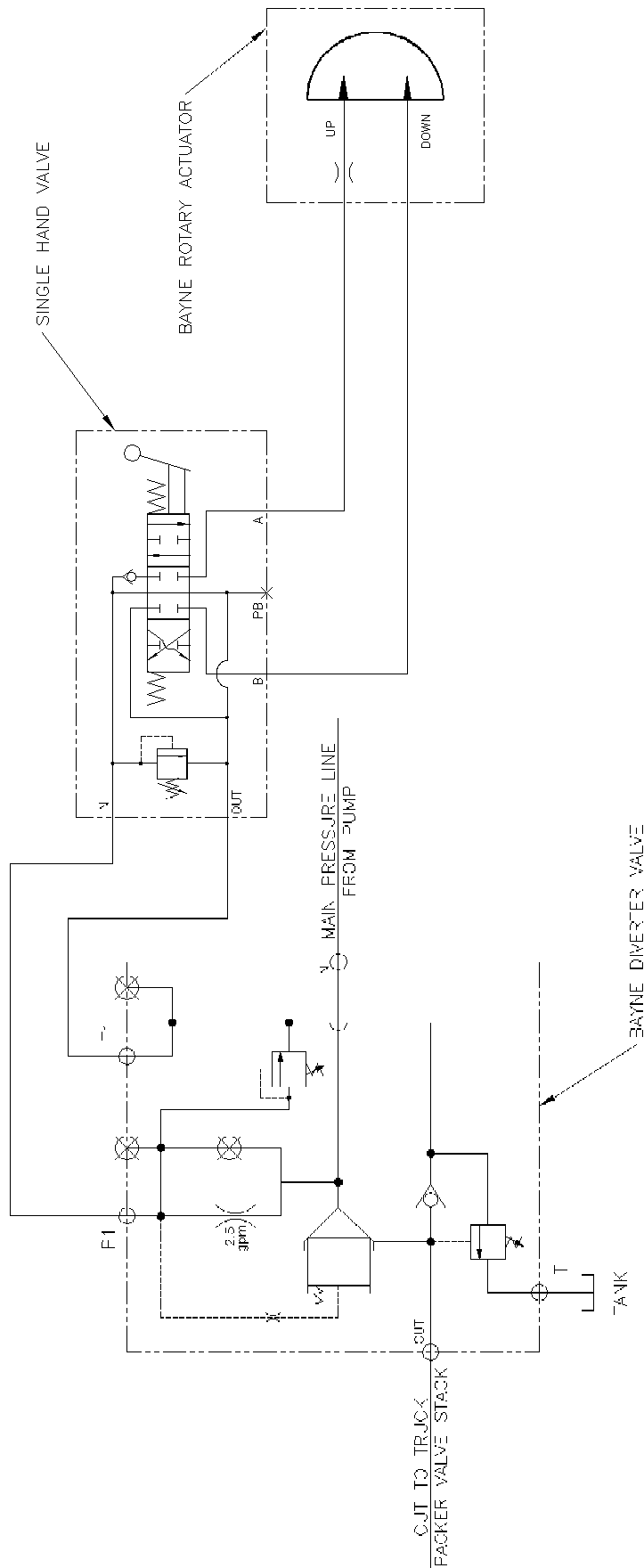

THIS IS A TYPICAL HYDRAULIC SCHEMATIC FOR A SINGLE LIFTER WITHOUT A VERTICAL INSTALLED ON A REAR OR SIDE LOAD REFUSE TRUCK.

CONFIDENTIAL		This drawing is private and confidential communication and the property of BAYNE MACHINE WORKS, INC., Greenville, S.C. It MUST NOT be copied or lent without consent of BAYNE MACHINE WORKS, INC., and must be promptly returned with tender and/or completion of order to the purchasing department.		SCALE:	SHEET	OF	REV.
BAYNE MACHINE WORKS, INC.		DATE:	CHKD BY:	NTS	1	:	-
3-D DRR SHOPS ROAD - GREENVILLE, SC 29635 - 664-2881-3377		TO: ERANCES IF NOT NOTED: 2000 = 2.0005 - 2.000 = 0.005 0.75 = 1.750 - 1.750 = 0.000	T.J.T.	DATE:	10/14/04		
		TITLE:		HYDRAULIC SCHEMATIC		DWG. NO.: 6900-073C	

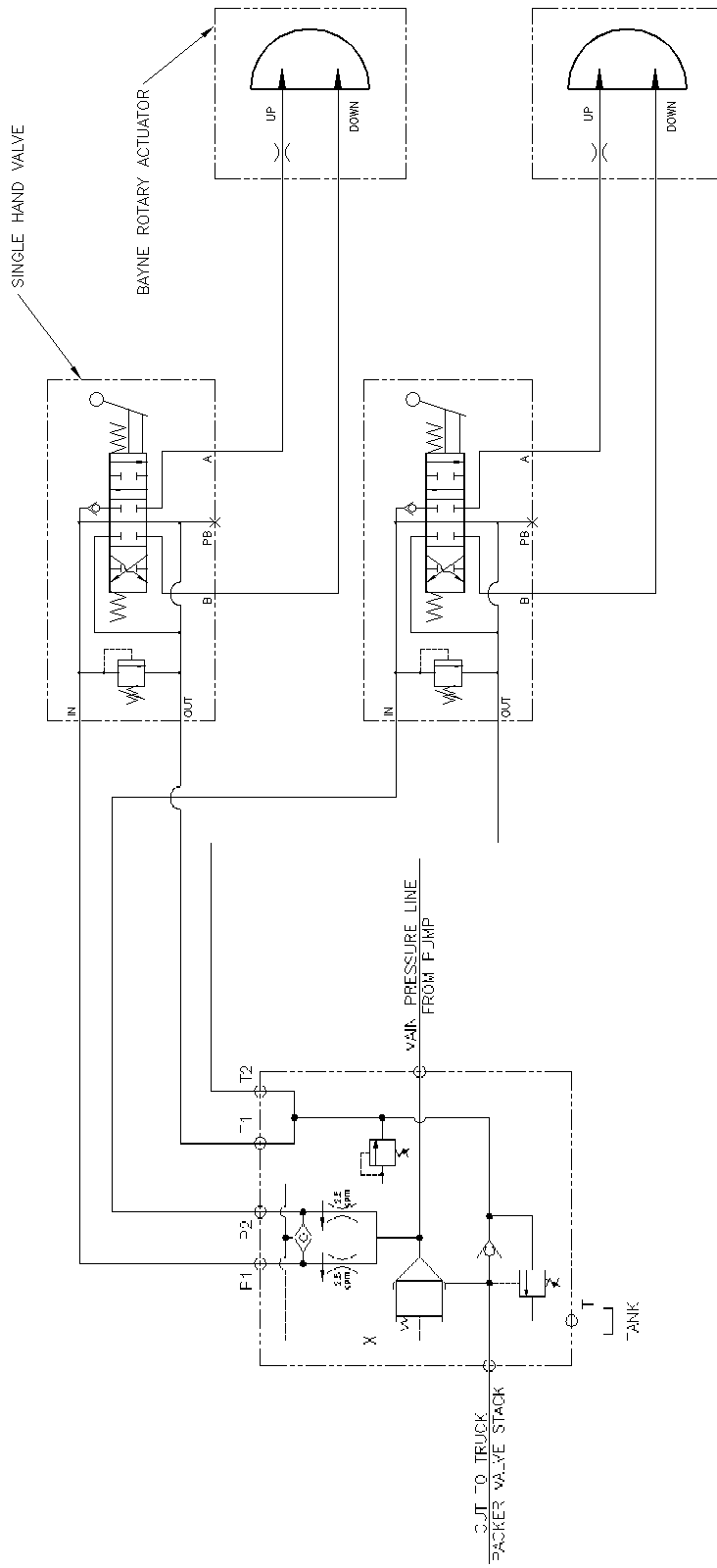

THIS IS A TYPICAL HYDRAULIC SCHEMATIC FOR A DUAL JIFTER WITHOUT A VERTICAL INSTALLED ON A REAR OR SIDE PACKER TRUCK.

CONFIDENTIAL		This drawing is private and confidential information and the property of BAYNE MACHINE WORKS, INC., Greenville, S.C. It MUST NOT be copied or lent without consent of BAYNE MACHINE WORKS, INC. and must be promptly returned to the purchasing department.		SCALE:	SHEET	OF	REV.
BAYNE MACHINE WORKS, INC.		D-BAYNE BY T.J.T.		NTS	1	1	-
3-0-DRR SHOPS ROAD - GREENVILLE, SC 29635 - 664-2881-3377		DATE: 10/20/04		TITLE:		DWG. NO:	
		CHKD BY:		HYDRAULIC SCHEMATIC		6900-C704	

SERVICE PARTS

ITEM	PORT	PART NO.	DESCRIPTION	SEAL KIT	APPLICATIONS
1	DFS	6091-0716	DIFF. PRESSURE SENSING VALVE	8000-0782	ALL
2	RV	6091-0712	RELIEF VALVE	8000-0784	ALL
3	PSV	6091-0713	PRESSURE SEQUENCE VALVE	8000-0781	ALL
4	FR-1	6091-0710	FLOW REGULATOR	8000-0784	FOR DUAL LIFTERS
5	FR-2	6091-0710	FLOW REGULATOR	8000-0783	FOR SINGLE LIFTER
6		6091-0715	CAVITY PLUG	8000-0783	FOR DUAL LIFTERS
7	DSV	6091-0720	SHUTTLE VALVE	8000-0784	ALL
8		6246-0008	INL. 8 SAE SOCKET HEAD PLUG	-	ALL
9	CV	6091-0714	CHECK VALVE	8000-0784	ALL
10	DR	6066-0028	Ø.028" DRIFICE	-	ALL

NOTE:

1. MAXIMUM WORKING PRESSURE 3000 PSI
2. MAXIMUM WORKING FLOW 50 GPM
3. TEMPERATURE RANGE = 16C° MAXIMUM
4. PORT SIZES
IN & OUT = #16 SAE
T = #10 SAE
5. T1, T2, P1 & P2 = #6 SAE
P1, P2 & P3 ARE PLUGGED USING #6 SAE
PLUGS IN SINGLE LIFTER APPLICATIONS

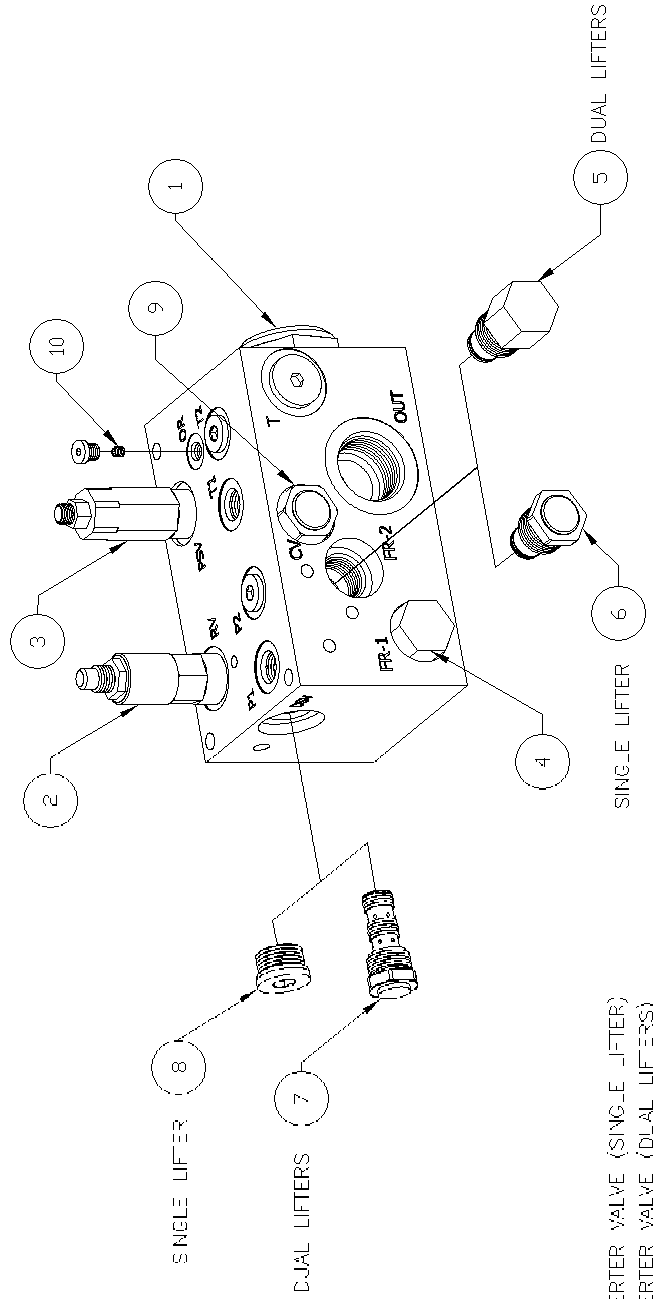

6091-0700 COMPLETE DIVERTER VALVE (SINGLE LIFTER)
 6092-0700 COMPLETE DIVERTER VALVE (DUAL LIFTERS)

CONFIDENTIAL		This drawing is private and confidential; communication and its property of BAYNE MACHINE WORKS, INC., Greenville, S.C. It MUST NOT be copied or lent without consent of BAYNE MACHINE WORKS, INC., and must be properly returned with tender and/or completion of order to the purchasing department.		SCALE:	SHEET	OF	REV.
BAYNE MACHINE WORKS, INC.		DATE:	CHKD BY:	1=2	1	1	A
3 CORK SHOALS ROAD - GREENVILLE, SD 57603 - 605-286-3377		DATE:	CHKD BY:	TITLE: SINGLE/DUAL		DWG. NO.:	
		DATE:	CHKD BY:	DIVERTER VALVE PARTS		M3500J05	

ITEM NO	PART NO.	DESCRIPTION	QTY
1	8000-0781	PRES. SEQUENCE VALVE SEAL KIT	1
2	8000-0782	PRESSURE SENSING VALVE SEAL KIT	1
3	8000-0783	SHUTTLE VALVE SEAL KIT	1
4		RELIEF VALVE SEAL KIT	1
5	8000-0784	FLOW REGULATOR SEAL KIT	1
6		FLOW REG. CAVITY PLUG SEAL KIT	1
7		CHECK VALVE SEAL KIT	1

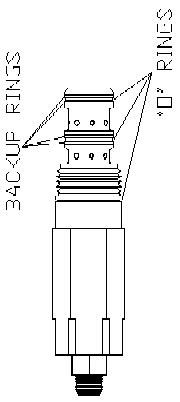

PRESSURE SEQUENCE VALVE SEAL KIT

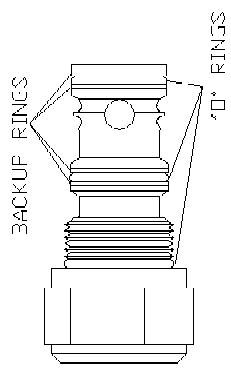

DIFFERENTIAL PRESSURE SENSING VALVE SEAL KIT

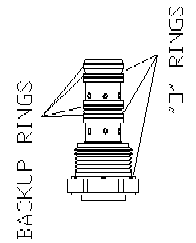

SHUTTLE VALVE SEAL KIT

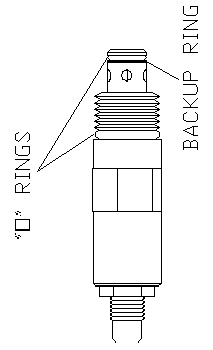

RELIEF VALVE SEAL KIT

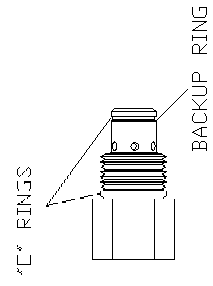

FLOW REGULATOR SEAL KIT

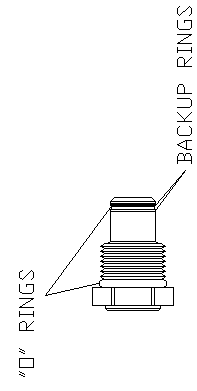

FLOW REGULATOR CAVITY PLUG SEAL KIT

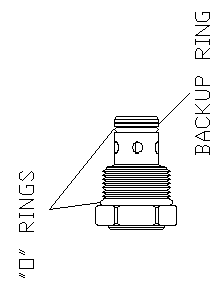

CHECK VALVE SEAL KIT

CONFIDENTIAL This drawing is private and confidential communication and the property of BAYNE MACHINE WORKS, INC., Greenville, S.C. It MUST NOT be copied or lent without consent of BAYNE MACHINE WORKS, INC., and must be promptly returned to the tender and/or completion of order to the purchasing department.

BAYNE MACHINE WORKS, INC.
 3-0 -DRK SHOLS ROAD - GREENVILLE, SC 29635 - 864-288-3377

TO: ERANCES IF NOT NOTED:
 200C = 2005 - 2006 - 2007 - 2008
 300C = 1/2009 - ANNUAL #0.25

DRAWN BY: T.C.T. DATE: 09/29/04
 CHKD BY: DATE:

SCALE: 2=3 SHEET 1 OF 1 REV: -

TITLE: DIVERTER VALVE SEAL KIT DWG. NO.: 8000-078C

ITEM	PART NO.	DESCRIPTION	CTY
1	6083-1025	HAND VALVE - 1750 PSI RELIEF	1
2	6083-1510	UNIVERSAL C-HOOK	1
3	6083-1511	CLEVIS PIN (ø3/16" x 7/8")	1
4	6083-1520	METRO/EATON H.V. HANDLE	1
5	8810-0303	COTTER PIN (1/16" x 1/2")	2
6	6220-0806	ST ADAPTER (#6 JIC x #6 SAE)	2
7	6248-0006	#6 JIC CAP NUT	2
8	7601-0003	HAND VALVE MOUNTING BRACKET	1
9	9001-0416	1/4-20 x 2" H.H.C.S.	2
10	9401-0400	1/4-20 HEX NUT	2
11	9700-0400	1/4" LOCK WASHER	2

NOTE:
 1. SEAL REPAIR KIT P/N : 8003-C385
 2. HANDLE REPLACEMENT KIT P/N : 5083-1501

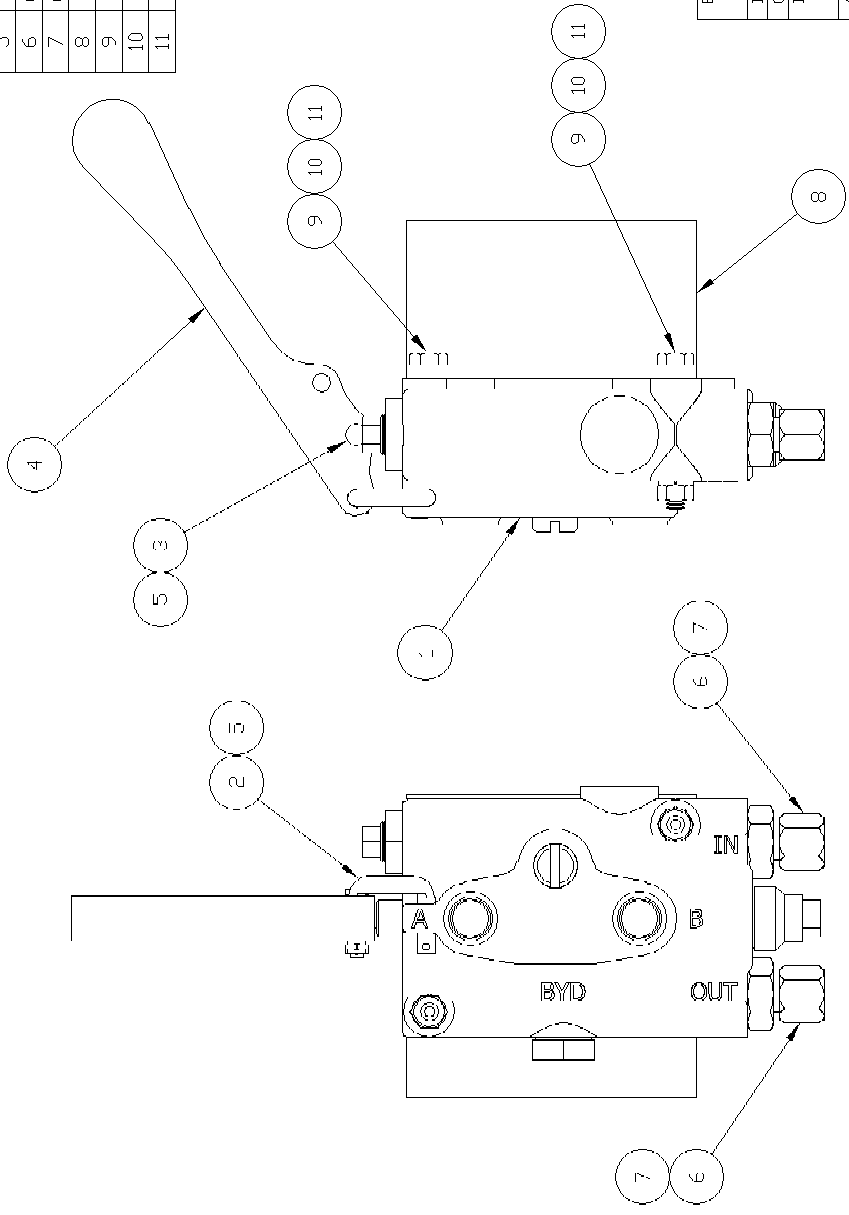

REV.	REVISED	DATE	REV. BY	CHK. BY	DATE	REV. BY	CHK. BY	DATE	REV. BY	CHK. BY	DATE	
E	6083-1025 WAS 6083-1020 ADDED 6083-1510 & 6083-1511 ADDED 6083-1520 & 8810-0303	05/24/07	CTT								05/24/07	CTT
D	REVISED 6083-1020 PICTORIALY	07/13/05	TJT									CTT
C	REVISED 6083-1020 PICTORIALY	03/30/99	TBR	RTM								CTT
B	6083-1020 WAS 6083-0420 ADDED 6220-0806 & 6248-0006 UPDATED DRAWING & TITLE BLOCK	05/15/98	CTT	RTM								RTM
A	REVISED 7601-0003 PICTORIALY	08/27/97	EFJ	RTM								08/27/97

CONFIDENTIAL This drawing is private and confidential information and the property of BAYNE MACHINE WORKS, INC., Greenville, S.C. It MUST NOT be copied or lent without consent of BAYNE MACHINE WORKS, INC. and must be promptly returned with tender and/or completion of order to the purchasing department.

TO: ERANCES IF NOT NOTED:
 200C = 1/32" - 200C = 0.015"
 30C = 1/32" - ANGULAR #0.25

DATE: 06/07/96 DATE: 06/11/96 DATE: 06/11/96

CHKD BY: BKB CHKD BY: BKB CHKD BY: BKB

TIER: TIER TIER TIER

SCALE: 2=3

SHEET 1 OF 1

TITLE: VALVE W/BRACKET

DWG. NO.: 6083-1020

ITEM NO	DESCRIPTION	QTY
1	RETAINING RING	1
2	3/32" x 1/2" I.D. O-RING	2
3	WIPER SEAL	1
4	3/32" x 41/64" I.D. O-RING	1
5	3/32" x 3/8" I.D. O-RING	1
6	1/16" x 1/2" I.D. O-RING	1
7	1/16" x 1/2" BACK-UP WASHER	1
8	3/32" x 5/8" I.D. O-RING	1
9	5/64" x 15/32" I.D. O-RING	1

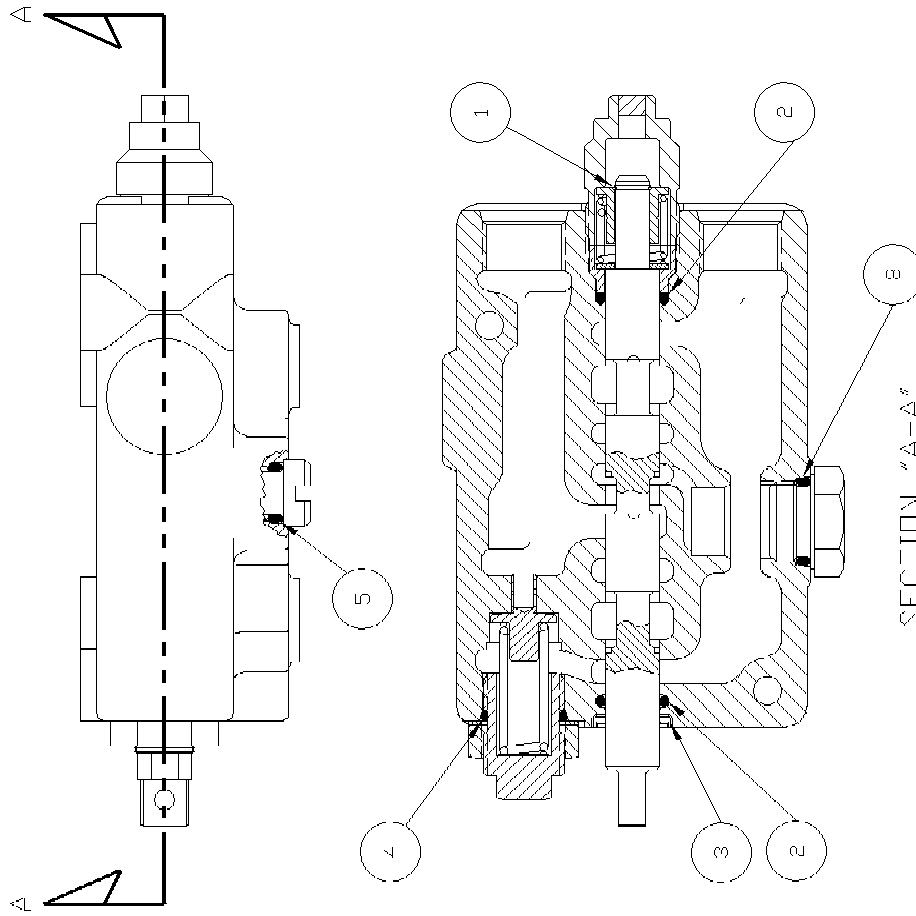

NOTES:

1. ASSEMBLY INSTRUCTIONS ARE INCLUDED WITH EACH KIT.
2. ITEMS 6,7 AND 9 ARE NOT USED WITH THIS HAND VALVE.

CONFIDENTIAL		This drawing is private and confidential communication and the property of BAYNE MACHINE WORKS, INC., Greenville, S.C. It MUST NOT be copied or lent without consent of BAYNE MACHINE WORKS, INC. and must be promptly returned with tender and/or completion of order to the purchasing department.		SCALE:	SHEET	OF	REV.
BAYNE MACHINE WORKS, INC.		DATE:	DATE:	1=1	1	:	-
3-D -DRK -SHOLS ROAD - GREENVILLE, SC 29635 - 664-2881-3377		DRAWN BY:	DATE:	TITLE:		DWG. NO.:	
		T.S.T.	07/20/05	HAND VALVE SEAL REPAIR KIT		8000-3085	
TOLERANCES IF NOT NOTED: 3/16" = 3/32" ± .001 3/8" = 1/32" ± .001							

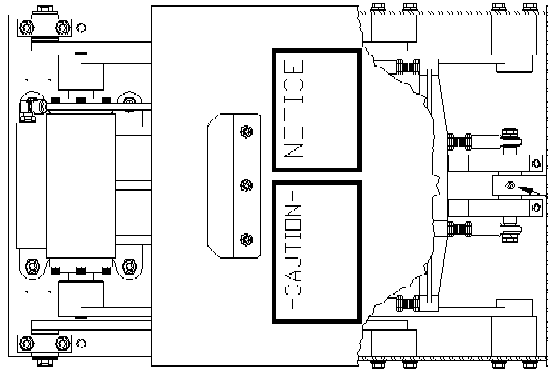

1
LOCATED
IN BACK

TO MAINTAIN WARRANTY AND FOR PREVENTIVE
MAINTENANCE GREASE ALL LUBRICATION POINTS
AT LEAST ONCE A WEEK

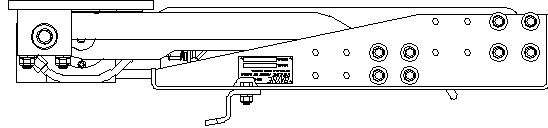

LUB POINTS 2-5 ARE
LOCATED ONE ON
EACH ROD END.

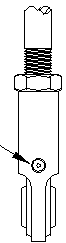

CONFIDENTIAL		This drawing is private and confidential communication and the property of BAYK E MACHINE WORKS, INC., Greenville, S.C. It MUST NOT be copied or lent without consent of BAYK E MACHINE WORKS, INC. and must be promptly returned with tender and/or completion of order to the purchasing department.		SCALE:	SHEET	OF	REV.
BAYK E MACHINE WORKS, INC. 301 DRR SHOLS ROAD - GREENVILLE, SC 29635		DATE:	CHKD BY:	NTS	1	1	-
TOLERANCES IF NOT NOTED: DIM = 0.005 - 0.001 DIA = 0.005 - 0.001 ANGULAR = 0.025		DATE:	CHKD BY:	TITLE:		DWG. NO.:	
		10/03/00	ANR	LUBRICATION POINTS		LUB2000P	



www.baynethinline.com

Customer Care:
800.535.2671

Fax:
256.585.6762

The Heil Co.
4301 Gault Avenue North
Fort Payne, AL 35967