



# Cart Lifter General Operation Guidelines

Always adhere to your company's safety guidelines when using this lifter. This includes wearing appropriate clothing and personal protective equipment, including reflective gear. Keep in mind that you are operating the lifter on public roads or alleys with moving traffic. Stay vigilant and watch out for vehicles and pedestrians.

The lifter should only be used for lifting ANSI-approved carts that are in good condition. It is not designed to be used as a step, to assist in lifting commercial containers, or to crush or break down items. Use with non-approved carts or misuse can result in serious injury or damage and will void the warranty.

Make sure the area around the lifter is free of personnel before operation. Always maintain a safe distance from the lifter to avoid pinch points that can cause serious injury.

Cart lifters can hang very low to the ground at certain points in the lift cycle. It is the operator's responsibility to move the lifter to a safe position, such as raising the lifter fully or placing the lifter in the storage position before driving. Lifters left hanging low risk bottoming out on the street, road, or alley. This can cause serious damage. Damages from bottoming out are not covered by the warranty.

It is the operator's responsibility to position the cart lifter safely before approaching any obstacles. Damages from collisions are not covered by the warranty.

## **TABLE OF CONTENTS**

|  | Page |
|--|------|
| I. <b>THINLINE</b> <sup>®</sup> Specifications _____                 | 3    |
| II. <b>THINLINE</b> <sup>®</sup> Installation Instructions _____     | 5    |
| III. <b>THINLINE</b> <sup>®</sup> Operation Instructions _____       | 12   |
| IV. <b>THINLINE</b> <sup>®</sup> Maintenance Instructions _____      | 14   |
| V. <b>THINLINE</b> <sup>®</sup> Actuator Assembly Instructions _____ | 15   |
| VI. Trouble-shooting Chart _____                                     | 27   |
| VII. Appendix A  |      |
| 1. Unit Assembly Drawings _____                                      | 31   |
| 2. Mounting Height Drawing _____                                     | 41   |
| 3. Hydraulic Schematic Drawings _____                                | 43   |
| 4. Lubrication Drawing _____   | 44   |

SPECIFICATIONS ( WI-0082-A )  
Bayne **THINLINE**<sup>®</sup> Premium Lift Systems

- A.** Rotary Actuator - rack and pinion style design.
- Rack, pinion, and shaft bearings are constantly lubricated by the hydraulic oil for extended life.
  - Body and caps are made of high quality ductile iron.
  - Pinion output shaft and racks are made of high tensile alloy steel.
  - The rotary actuator provides smooth motion throughout the lift cycle, which results in longer cart life with virtually no cart damage or abuse.
- B.** Arm bearings are made of a composite material which provides superior compression strength along with self-lubrication, thus eliminating the need to grease the arm bearings.
- C.** The **THINLINE**<sup>®</sup> lift unit can measure as little as 8 1/2” thick from the back of the mainframe to the front of the lifter, depending on the types of arms used.
- D.** The faceplate is normally at 45 degrees in the dump position and extends 13” to 15” from the back of the mainframe into the hopper or container opening. This places the cart or barrel 16” to 18” into the truck or container opening thus reducing any potential spillage of materials.
- E.** Cycle times for safe, fast, efficient service.
- **6 - 8 seconds** for Actuator to rotate up and down.
  - **3 - 4 seconds** for GTL arms to rotate down, clamp, unclamp, and rotate up.
- Note : Cycle time is controlled by flowrate, as flowrate increases, cycle times decrease.*
- Warning : Never exceed the cycle times listed above. In order to avoid injury and maintain manufacturer’s warranty never operate outside of these recommendations.***
- F.** Recommended flow rates are as follows:
- **2 to 2 1/2 GPM** for 1100 series units
  - **2 to 4 GPM** for 2200 series units
- G.** Hydraulic pressure requirements are as follows:
- **1800-2000 PSI** normal working pressure
  - **3000 PSI** maximum pressure



- H. All lifters can be a bolt on type installation for easy, quick maintenance and less downtime.
- I. All parts are manufactured and kept in stock at Bayne Machine Works, Inc. for fast response to customer request.
- J. Two ( 2 ) year limited warranty from date of delivery on all units and models when properly maintained and operated within the recommended cycle time.

*All lift units and parts are inspected by our Quality Control Department before shipment to insure that you always receive the highest quality available in the lift business.*

For more information, please contact us at 1/800/535-2671 or by fax at 1/864/458-7519.

# INSTALLATION INSTRUCTIONS ( WI-0216-B)

## Bayne *THINLINE*<sup>®</sup> Premium Lift Systems

The following information is intended to be a **GENERAL GUIDE** to installing the Bayne *THINLINE*<sup>®</sup> lifter on a typical refuse truck. Before starting the installation, read these instructions completely. **ALWAYS** use the proper tools, lift devices, and personal protective equipment to prevent injury while performing the installation.

**NOTE:** If a Bayne *THINLINE*<sup>®</sup> Tap-In Kit was also acquired for this installation, refer to the installation instructions included in the Tap-In Kit manual for more detailed information.

### I. Mounting lifter on the truck :

1. The truck should be emptied and cleaned before any installation. The truck should be parked on a level solid surface, a concrete floor if possible.
2. All lights, tags, steps, etc. that will interfere with the installation should be removed and/or relocated.
3. Position the lifter(s) on the sill of the truck per *figures I-1 & I-2* and mounting height drawing ( *Appendix A* ) and tack weld in place ( *later in the installation procedure the final weld will be applied* ).

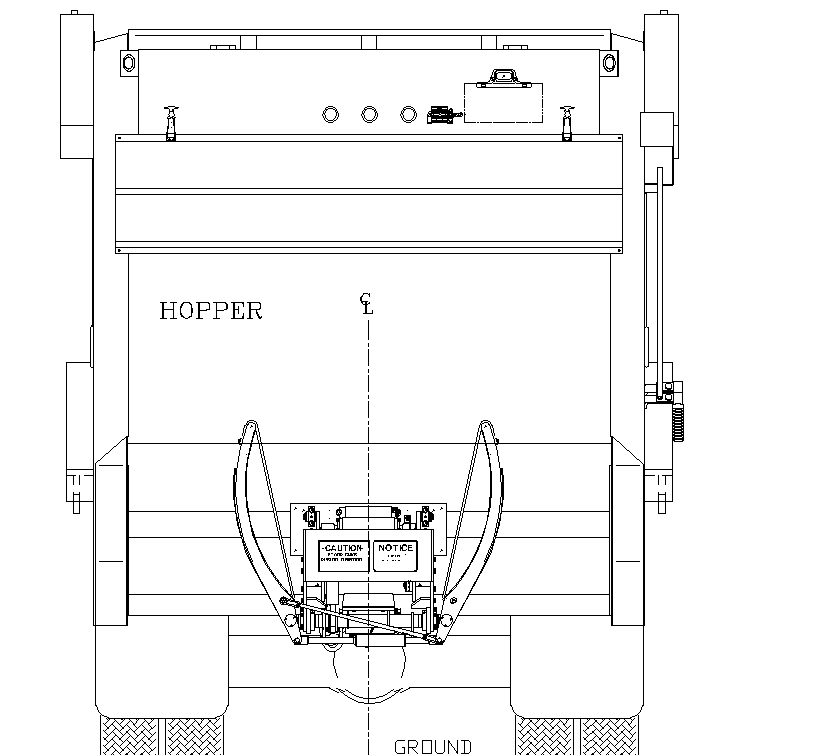
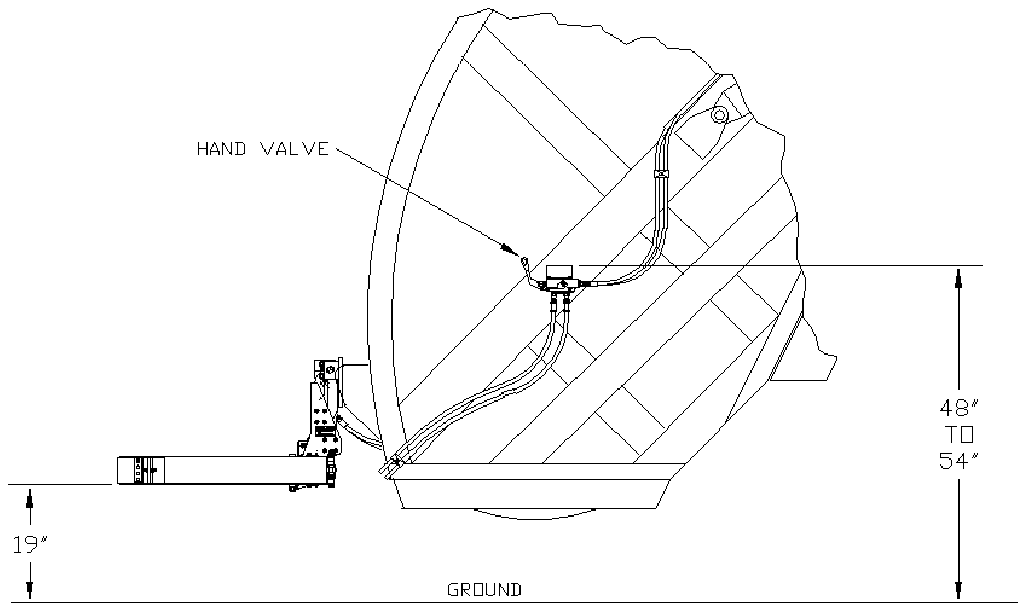

figure I-1



**figure I-2**

**II. Making Hydraulic Connections :**

*Before attempting any hydraulic connections, turn the truck's engine off and release all hydraulic pressure from the system. Refer to the hydraulic layout ( figure I-3 ) and hydraulic schematic ( Appendix A ) while performing the following steps.*

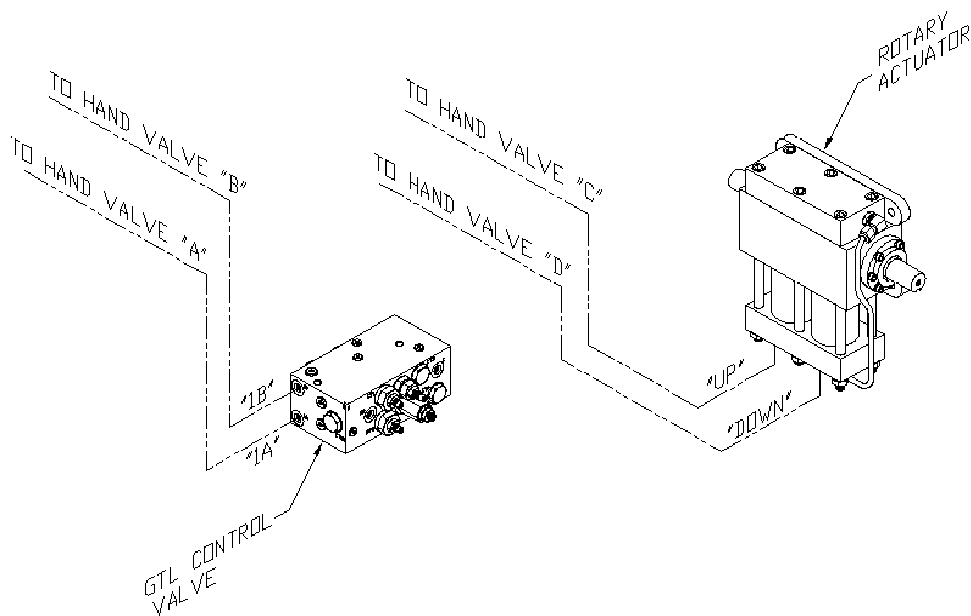

**figure I-3**

1. Connect the hose from the “UP” port of the rotary actuator to the “C” port of the dual hand valve.
2. Connect the hose from the “DOWN” port of the rotary actuator to the “D” port of the hand valve.
3. Connect the hose from the “1A” port of the GTL control valve to the “A” port of the hand valve.
4. Connect the hose from the “1B” port of the GTL control valve to the “B” port of the hand valve.

### III. Adjusting the GTL control valve :

*The rotational and clamping motions of the THINLINE<sup>®</sup> GTL lifter’s arms are controlled through a series of valves in the GTL control valve mounted to the lifter.*

*Pressurizing the “1A” port of this manifold will rotate the arms down to the horizontal position. As the arms reach the horizontal position, the sequence valve in port “CT4” senses the pressure increase, then shifts to direct oil to the clamping cylinder, causing the arms to clamp. Pressurizing the “1B” port of the control valve will unclamp the arms. As the arms reach the fully unclamped position, the sequence valve in port “CT1” senses the pressure increase, then shifts to direct oil to the rotate cylinder, returning the arms to the upright position.*

*The GTL control valve includes a pressure reducing valve in port “CT5” to control the clamping pressure.*

*It is very important to make sure the hydraulic oil is at operating temperature, and the flow rate and relief valve settings have been properly adjusted before setting the GTL control valve pressures. The proper flow rate and relief settings are 2 gpm at 1800 psi.*

*Start the adjustment process with the GTL arms in the “up” position as shown in figure I-4 and rotate the lifter into the dump position as far as you can without hitting the arms on the truck. This should allow better access to the GTL control valve.*

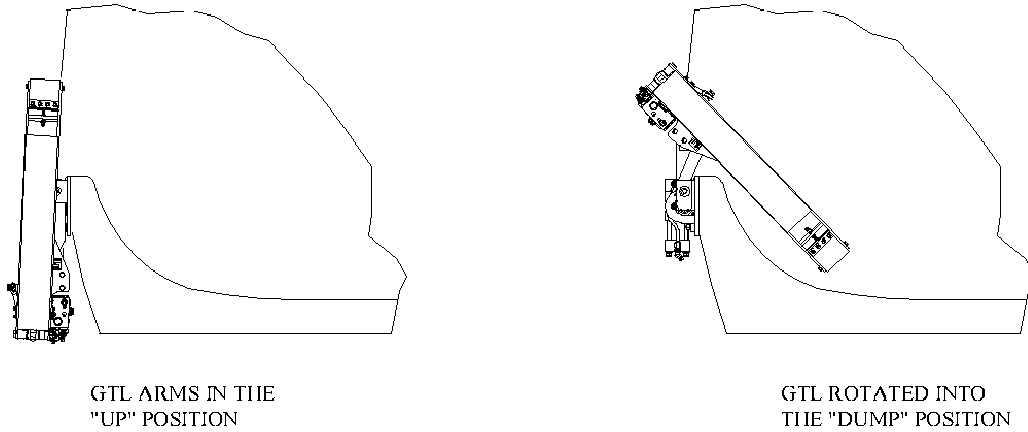
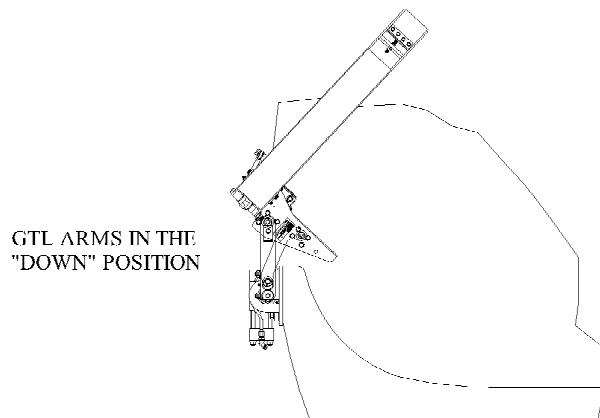

**figure I-4**

1. Adjusting the GTL Sequence Valves :

*As stated above the rotational and clamping motions of the GTL arms are controlled with the use of sequence valves. These valves are preset from the factory to operate properly on most trucks without any adjustment. However, if the arms will rotate down but will not clamp, or if the arms will unclamp but not rotate up, refer to Figure I-6 while performing the following steps to properly adjust the sequence valves.*

- a) Start the truck's engine and engage the hydraulic system.
- b) Loosen the lock nuts on the sequence valves in ports "CT1" and "CT4" of the GTL control valve, and using an allen wrench turn the adjustment screws clockwise until they bottom out.



**figure I-5**

- c) Shift the handle of the dual hand valve to move the arms to the “down” position. ( *Figure I-5* ) After the arms completely rotate down, release the handle on the dual hand valve.
- d) Use the allen wrench to turn the adjustment screw ( *figure I-6* ) on the sequence valve in port “CT4” counter-clockwise 1/4 turn. Remove the allen wrench and move the handle on the dual hand valve to see if the valve will shift to clamp the arms. If the arms do not clamp, release the handle on the dual hand valve, and repeat this procedure, backing the adjustment screw out in 1/4 turn increments until the arms clamp. **Note: It may take as many as 10 to 15 adjustments.**
- e) Move the handle on the dual hand valve the opposite direction, causing the GTL arms to unclamp. After the arms completely unclamp, release the handle on the dual hand valve.

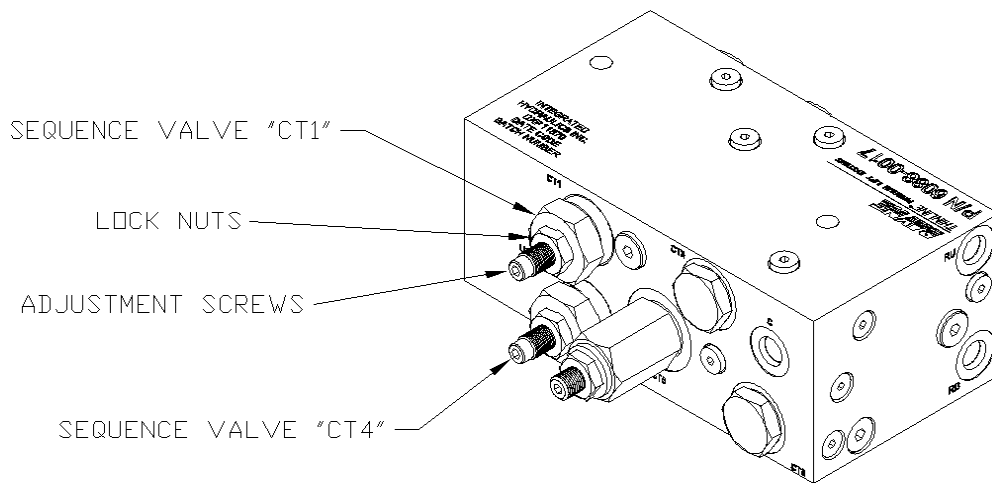

**figure I-6**

- f) Use the allen wrench to turn the adjustment screw on the sequence valve in port “CT1” counter-clockwise 1/4 turn. Remove the allen wrench and move the handle on the dual hand valve to see if the valve will shift to rotate the arms to the “up” position. If the arms do not rotate to the “up” position, release the handle on the dual hand valve, and repeat this procedure, backing the adjustment screw out in 1/4 turn increments until the arms rotate. **Note: It may take as many as 10 to 15 adjustments.**
- g) Tighten the lock nuts on the sequence valves to secure the correct pressure settings.

## 2. Adjusting the Clamp Pressure Valve :

*The amount of pressure the GTL arms use to clamp the container is controlled with a pressure reducing valve in the “CT5” port of the GTL control valve. This valve is preset at the factory to operate with most containers. However, if the lifter seems to be crushing or losing grip on your specific containers, refer to Figure I-7 while performing the following steps to properly adjust the clamping pressure.*

- a) Place a container into the grabber arms, clamp, and rotate the lifter to the dump position.
- b) Loosen the lock nut on the pressure reducing valve in port “CT5” of the GTL control valve.
- c) If the lifter is crushing the waste container, turn the adjustment screw counter-clockwise 1/4 turn. If the lifter is losing grip on the waste container, turn the adjustment screw clockwise 1/4 turn.

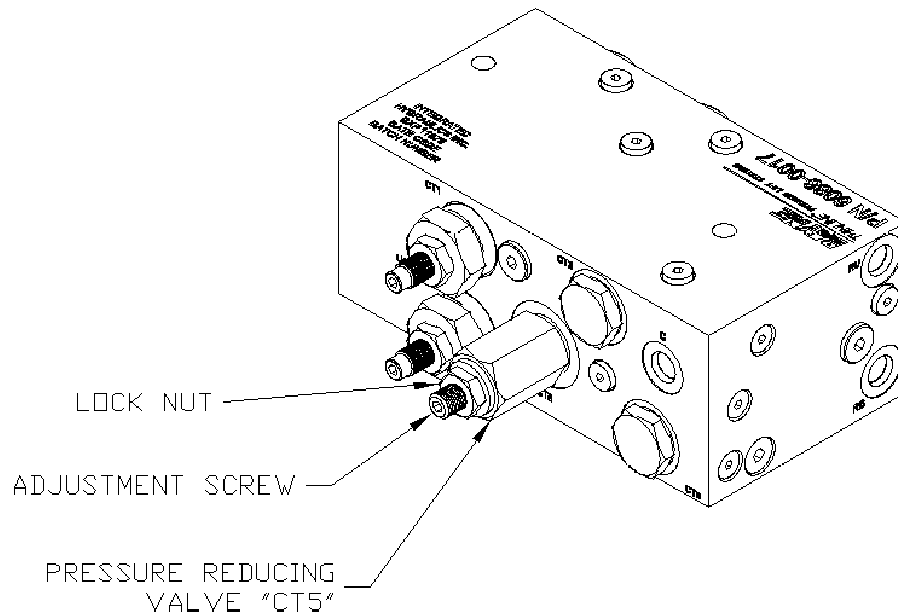

*figure I-7*

- d) Lower the container back down, unclamp, and rotate the grabber arms back to the “up” position.
- e) Repeat clamping and dumping the container, making necessary adjustments to the pressure reducing valve in 1/4 turn increments until the lifter securely holds the container without crushing it.
- f) Tighten the lock nut on the pressure reducing valve to secure the correct pressure setting.

#### **IV. Final operation and mounting:**

1. Start the truck's engine and engage the hydraulic system.
2. Operate the lifter and bleed all air from the hydraulic system.
3. Place a cart on the lifter and operate to make sure there are no clearance problems and that the lifter engages the cart properly. Make any adjustments to the mounting position of the lifter to ensure correct operation.
4. After locating an acceptable mounting position, complete the welding of the lifter to the truck.



## OPERATION INSTRUCTIONS ( WI-0135-A )

### *Bayne THINLINE*® Premium Lift Systems

The *Bayne THINLINE*® Premium Lift System is a high quality durable cart lifter built to meet your industry's requirements. To insure the safety of all operators of this equipment, please read this manual carefully before operating the lifter. ***FAILURE TO COMPLY WITH INSTRUCTIONS COULD RESULT IN PERSONAL INJURY AND/OR PROPERTY DAMAGE.***

The operating stages ( *figure O-1* ) in the cycle of the cart lifter are as follows:

- 1) ***START*** - The cart to be dumped is rolled up to the lifter. *The cart must be placed in close proximity to the front of the lifter to ensure that the clamp arms will fully engage the cart. Also, the cart must be centered to ensure there is no interference when the clamp arms are lowered.*
- 2) ***CLAMPING*** - The clamp arms are lowered and engaged around the cart.
- 3) ***ACTUATOR DUMP*** - The rotary actuator is cycled to dump the contents of the cart.
- 4) ***ACTUATOR REVERSE*** - The rotary actuator is reversed, returning the cart to the ground.
- 5) ***UNCLAMPING*** - The clamp arms are unclamped and return to the upright position.

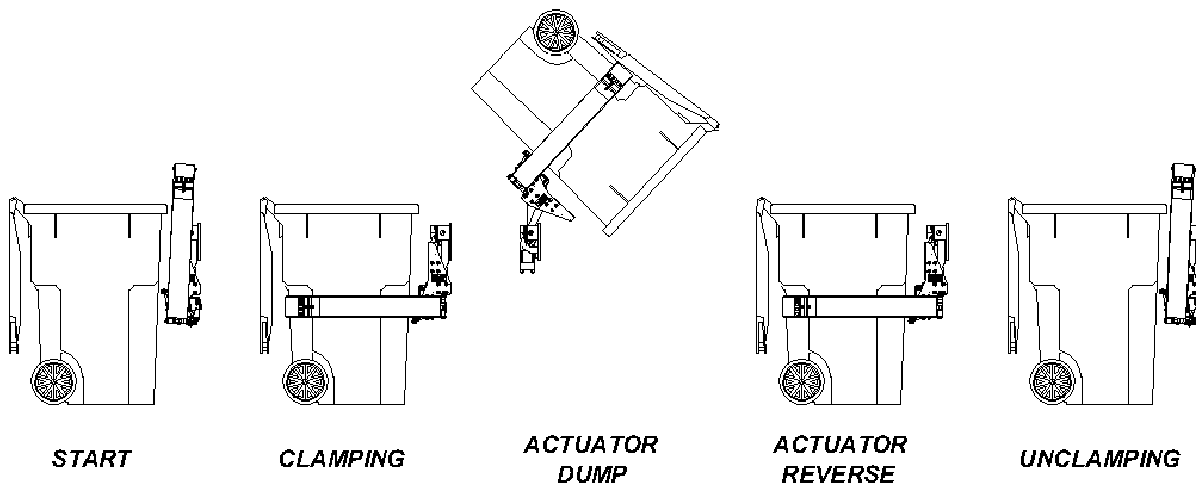

**figure O-1**

The rotational and clamping motions of the cart lifter are controlled with the use of a dual hand valve. Moving the grabber arm handle on the dual hand valve in the upward direction will cause the grabber arms to perform the *CLAMPING* stage (*figure O-1*). Moving the actuator handle in the upward direction will cause the lifter to perform the *ACTUATOR DUMP* stage. Moving the actuator handle in the downward direction will cause the lifter to perform the *ACTUATOR REVERSE* stage. Finally, moving the grabber arm handle in the downward direction will cause the lifter to perform the *UNCLAMPING* stage.

## UNCLAMPED WIDTH ADJUSTMENT

Check the distance between the outsides of the grabber arms when the lifter is in the fully *UNCLAMPED* position as shown in figure O-2. Maintain this dimension at **41 1/2"**.

To adjust the setting, loosen the jam nuts on the spherical rod ends. Remove the bolt that holds the rod end to the grabber arm. Screw the rod ends in or out as required to obtain the proper dimension of **41 1/2"**. Reinsert the bolt to attach the rod end to the grabber arm and tighten the jam nuts.

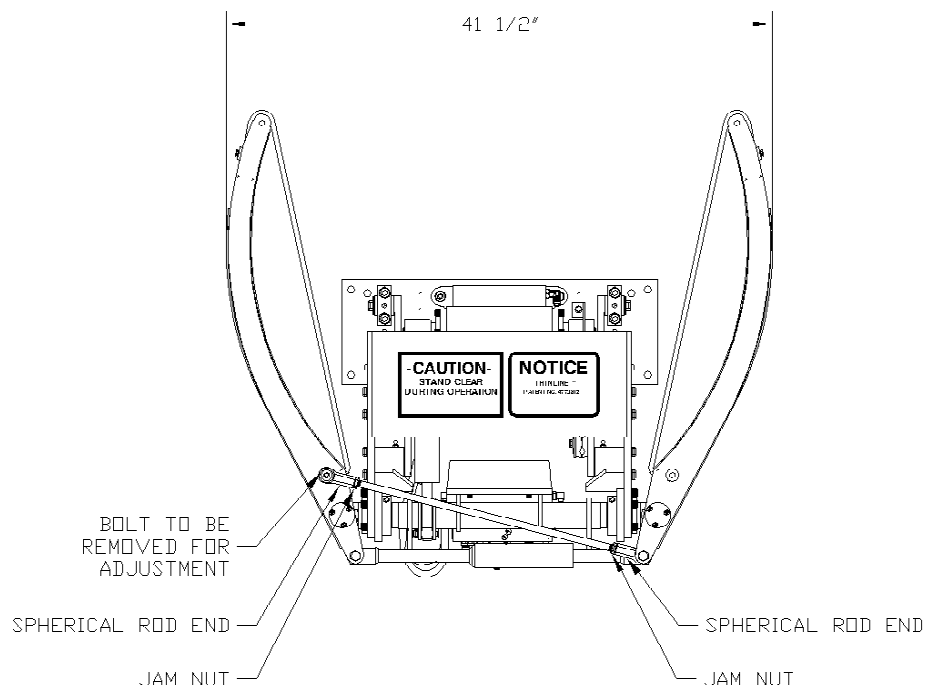

**figure O-2**

MAINTENANCE INSTRUCTIONS ( WI-0140-A )

Bayne ***THINLINE***<sup>®</sup> Premium Lift Systems

**NOTE:**

THE MOST COMMON CAUSE OF HYDRAULIC COMPONENT FAILURE IS CONTAMINATION OF THE HYDRAULIC FLUID ( WATER, CHIPS, DIRT, ETC. ) THE Bayne ***THINLINE***<sup>®</sup> LIFT SYSTEM COMES CLEAN FROM THE FACTORY. IF REMOVED, BE SURE THE HOSES, CYLINDER AND FITTINGS ARE CLEAN BEFORE RE-INSTALLING THEM ON THE UNIT.

Inspect your cart lifter on a weekly basis for loose bolts, fittings, oil leaks, etc. Tighten loose hardware as necessary and replace necessary seals to repair oil leaks.

In order to maintain warranty and for preventive maintenance, grease all points weekly with a good multi-purpose grease at points shown in the lubrication drawing ( *APPENDIX A* ).

# BAYNE

## PREMIUM LIFT SYSTEMS

### ASSEMBLY INSTRUCTIONS

#### 1100 SERIES ROLLER BEARING ACTUATOR

PART NUMBER 1122-1015 ( WI-1116-D )

LICENSED UNDER ONE OR MORE OF THE FOLLOWING U.S. PATENTS:  
4,773,812    1,327,765    5,308,211    5,333,984

#### READ INSTRUCTIONS COMPLETELY BEFORE STARTING ASSEMBLY.

Before starting the assembly of the Rotary Actuator, refer to the exploded parts drawing and parts list (fig. A-13 found at the end of these instructions) to familiarize yourself with the individual components. Prepare a clean surface, in an area free of blowing dust and contaminants in which to assemble the Rotary Actuator. Be sure that all parts are thoroughly clean and dry before starting assembly.

**NOTE:** All torque values given apply to clean dry threads only. Follow these directions closely when repairing the Rotary Actuator.

1. Install the piston seal load ring (13) (fig. A-1) in the small groove on the head of the actuator rack (2). Place the “square” piston seal (17) over the load ring (13) in the same small groove (a small “blunt” flathead screwdriver may be used, taking care not to scratch or damage the seal). Install the wear ring (18) in the large groove on the head of the rack. Using a ring compressor, firmly seat the rings on the rack before setting it aside, this will help to reverse the effects of any stretching of the rings that occurred during installation. Repeat this procedure for the other rack.

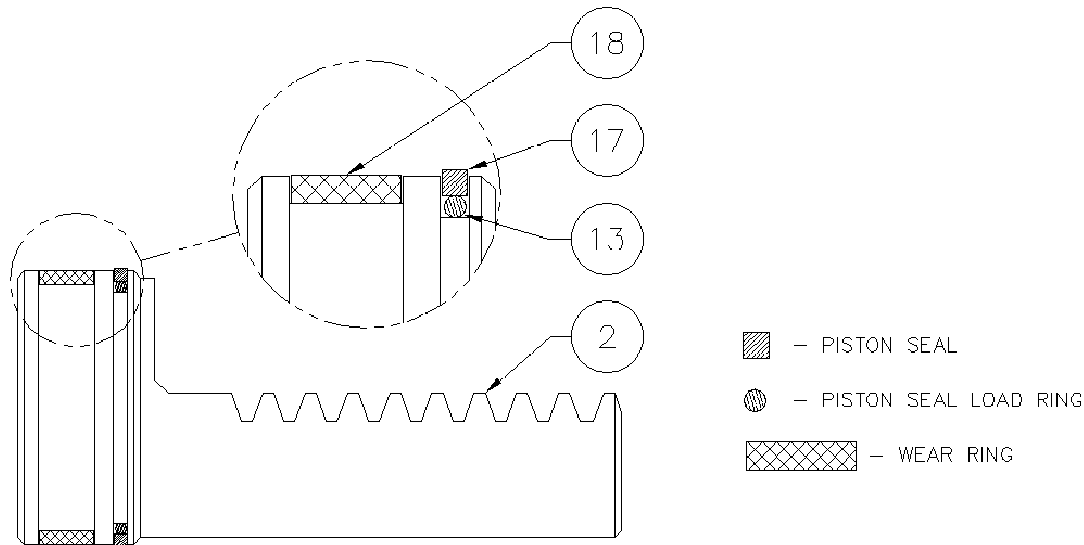
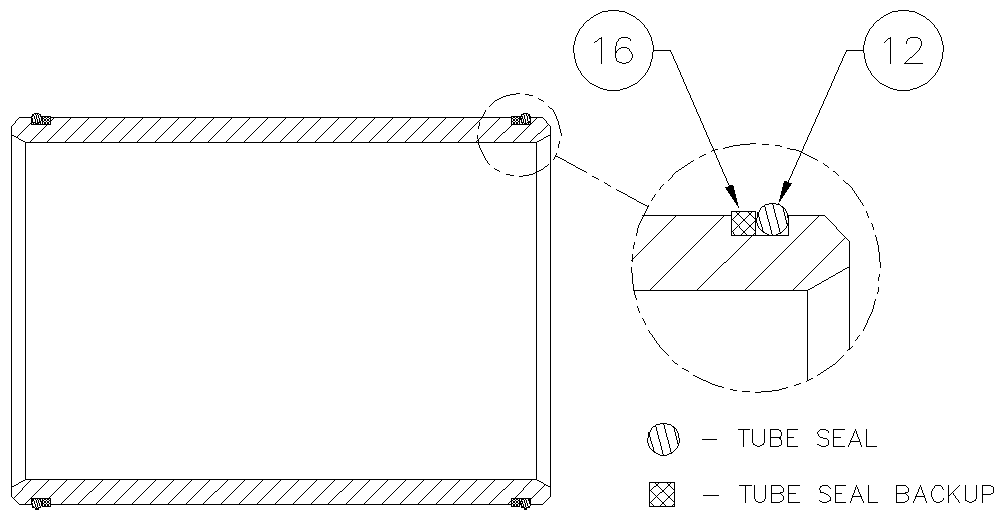

figure A-1

2. Install the tube seal (12) (fig. A-2) and “square” tube seal backup (16) on each end of the actuator tubes (3) (fig. A-13). Be sure that the “square” tube seal backup ring is toward the inside of the tubes at both ends as shown. Press all rings firmly into the grooves. Repeat this procedure for the other tube.



**figure A-2**

3. Thoroughly clean the pinion shaft (1) (fig. A-3) and inner races (10) with a mild solvent and dry completely. Spray the inner race contact area (shown in figure A-3) at each end of the pinion shaft and the inside diameter of the inner race thoroughly with *LOCTITE 7649 N PRIMER*. Apply *LOCTITE RETAINING COMPOUND 609* around the pinion shaft at contact area and the inside diameter of the inner races. Slide the inner races (10) on the pinion shaft (radius end first as shown in figure A-3) until the races seat against the gear teeth. After the races seat against the gear teeth, twist the races on the pinion 360° to spread the retaining compound evenly. Wipe off any excess retaining compound.

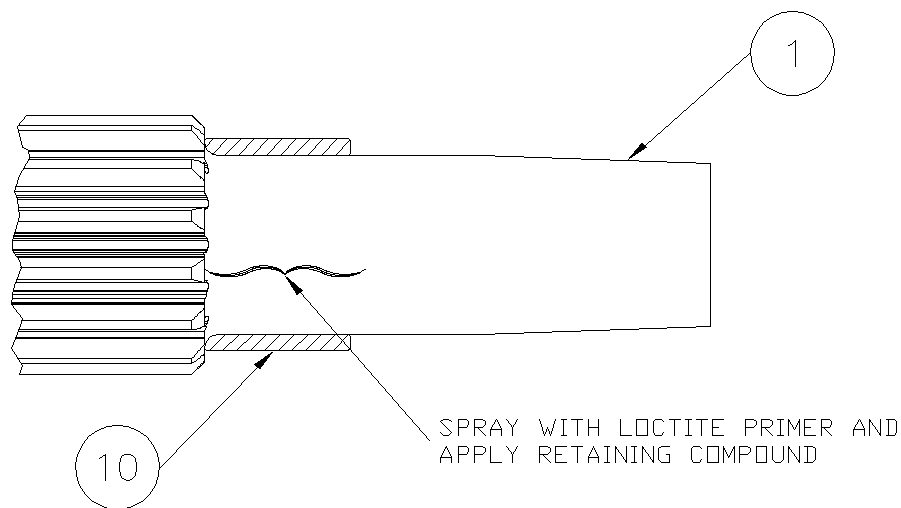

**figure A-3**

- Place the actuator body (7) (fig. A-4) on the edge of the table, mounting flanges closest to the assembler with the counter-bores facing up. Insert the pinion shaft (1) through the bore on either side of the actuator body with the key ways facing back toward the mounting flanges and up away from the table with the center line of the key ways pointing toward the center of the tapped hole shown in figure A-4. Center the pinion in the actuator body.

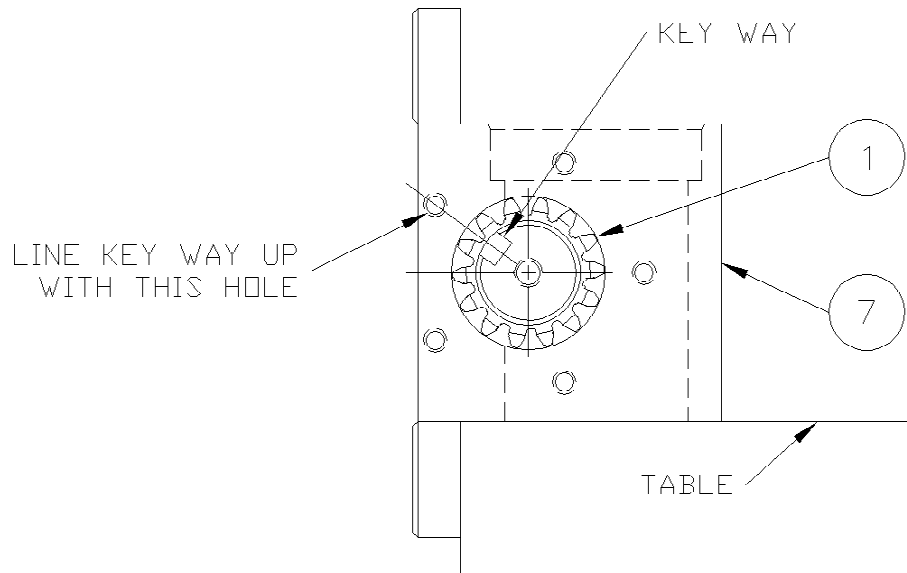

**figure A-4**

- Coat the head portion of the racks (2) (fig. A-13) with STP Oil Treatment. Install the racks, head portion up with the teeth facing the flanges of the actuator body, into the dual set of bores in the body. Simultaneously slide the racks into the bores so that the racks mesh with the pinion in the same position. Rotate the pinion shaft to engage the racks into the pinion.

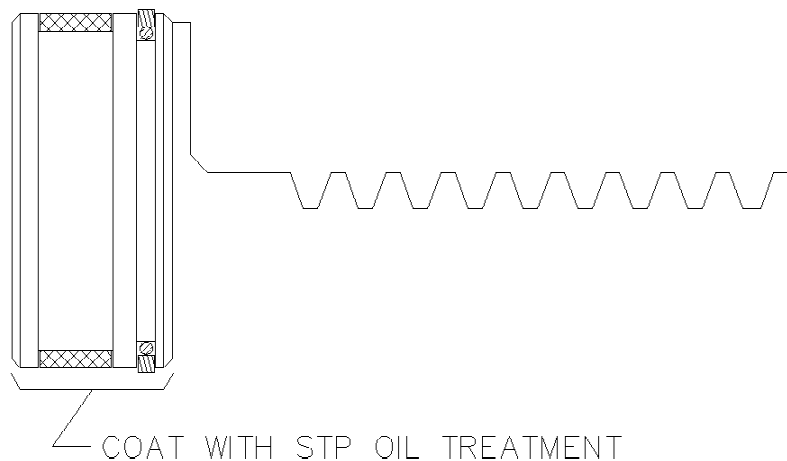

**figure A-5**

6. Check the position of the racks in the pinion by making sure both racks seat against the actuator body at the same time and also when the racks are seated against the body, the key ways on the pinion shaft should be facing down toward the table and very slightly back toward the mounting flanges on the actuator body as shown in figure A-6.

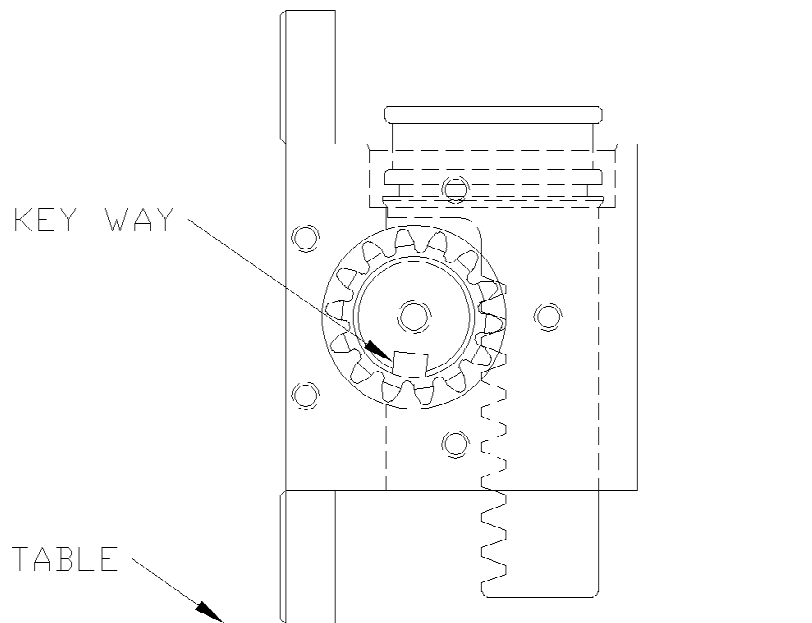

**figure A-6**

7. Coat one end of the actuator tubes (3) (fig. A-13) around the seal area with STP Oil Treatment as shown in figure A-7. Using a rubber mallet, drive the coated end of the tube onto the exposed rack until the tube end seats in the actuator body, making sure that the seals remain in place as the tube enters the counter-bore. Repeat this procedure for the other side.

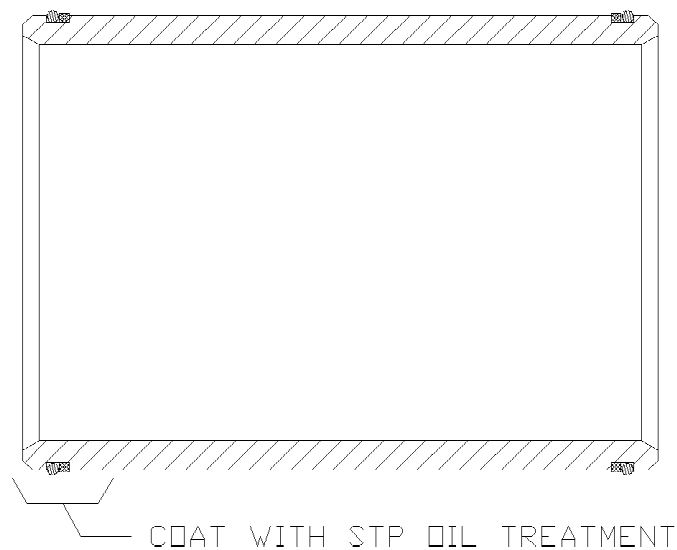

**figure A-7**

8. Install the six tie rod studs (6) (fig. A-13) by screwing the short threaded end into the actuator body. Hand tighten only at this time (the torque needed will be applied later in the procedure).
9. Place the tube cap (4) (fig. A-13) on the table. Coat the sides of the two bores in the tube cap with STP Oil Treatment. Install the cap over the tubes and rod studs with the oil port positioned to the left as shown in figure A-13. Using a rubber mallet, tap the tube cap over the tubes until the tubes seat in the cap, making sure that the seals remain in place.
10. Place the tube mounting bracket (30) (fig. A-13) over the two end rod studs opposite the oil port in the tube cap as shown in figure A-13.
11. Install the hex nuts (23) (fig. A-13) and lock washers (24) on the tie rod studs. Torque the nuts to 50 ft-lb. in the sequence shown in figure A-8.

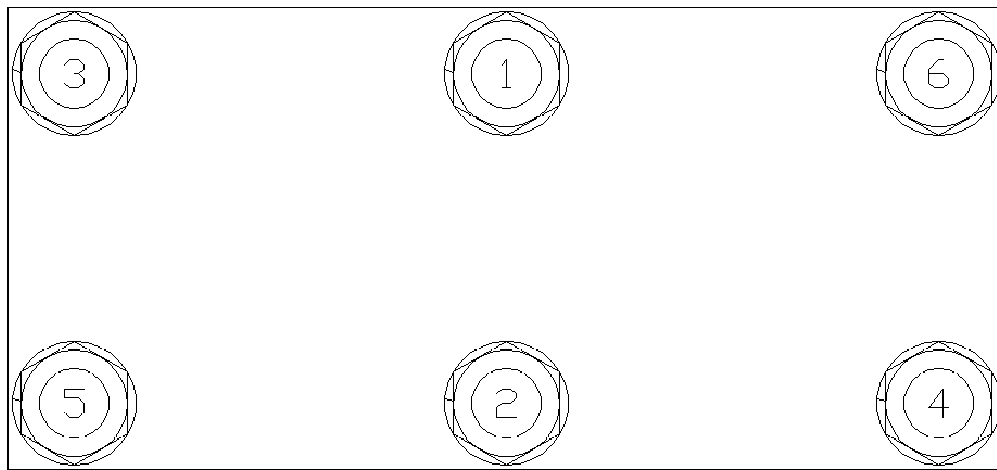

TUBE CAP TORQUE SEQUENCE

**figure A-8**

12. Place the rack cap (5) (fig. A-13) bore side up on the table and coat the edge of each bore with STP Oil Treatment. Install the rack cap seals (14) (fig. A-9) in the rack cap.



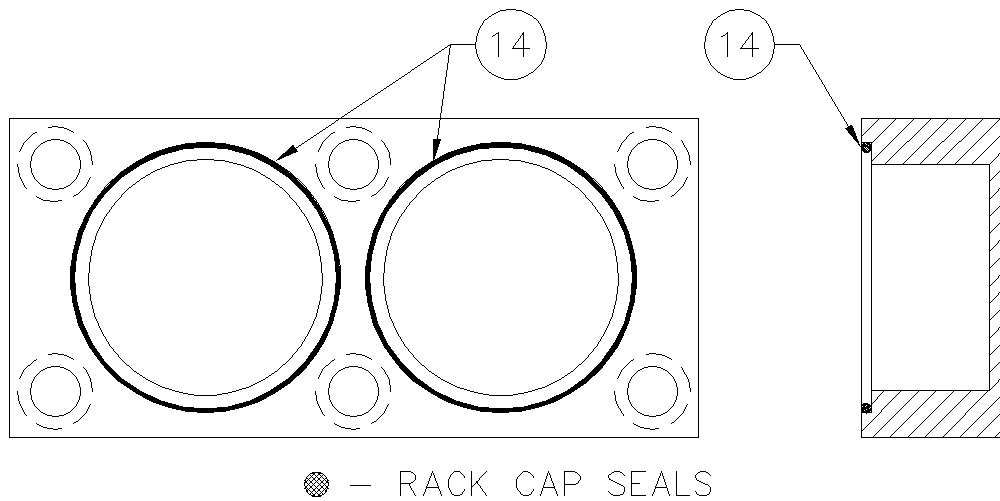

**figure A-9**

13. Reposition the actuator on the table mounting flanges down, and the lower tubes facing away from the assembler. Rotate the pinion shaft to allow 1” of the rack to protrude from the top of the actuator body. Install the rack cap with the oil port positioned to the left hand side of the actuator opposite the bottom oil port located in the tube cap as shown in figure A-13. Attach the rack cap to the actuator body using the socket head bolts (22) (fig. A-13) and lock washers (26). Torque the bolts to 90 ft-lb. in the sequence shown in figure A-10.

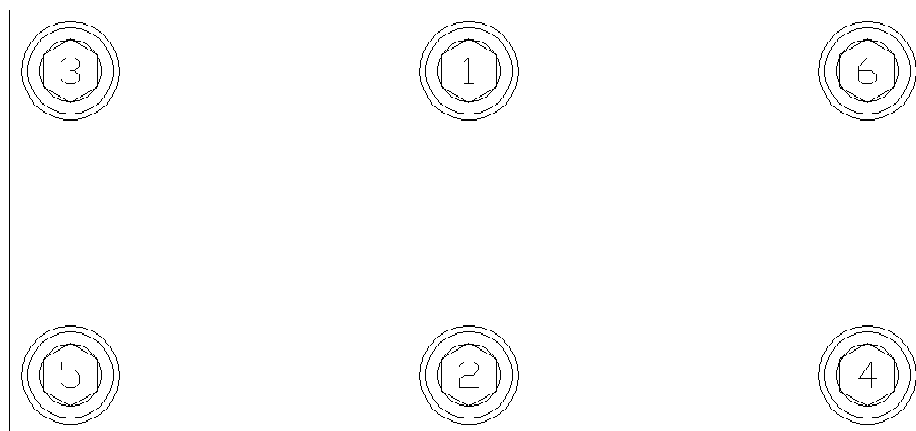

RACK CAP TORQUE SEQUENCE

**figure A-10**

14. Reposition the actuator so that the pinion shaft can be rotated with no obstacles. Rotate the pinion shaft to ensure that the racks move freely. Also make sure that the key ways point perfectly straight “up” toward the rack cap and “down” toward the tube cap at each end of the 180° stroke. If the assembly does not perform all of these functions correctly, it must be disassembled, cleaned, and reassembled.

15. Re-center the actuator pinion in the actuator body by tapping on one end of the shaft with a rubber mallet. Install the roller bearing (9) (fig. A-13), over the pinion shaft and inner race, and into the actuator body. Repeat this procedure for the other bearing.
16. Thoroughly clean the bearing caps (8) (fig. A-11) with a mild solvent and lubricate all seal grooves with STP oil treatment. Place the bearing caps (8) on the table (mounting surface down) and install the wiper ring (19) in the outside groove using a rubber mallet or small press. *(Avoid using tools that may damage seals or scratch bearing cap or bearing surfaces.)* Turn the bearing cap (8) over. Collapse the pinion seal (20) and carefully work it into the groove. Use fingers to carefully press the seal completely into the groove as shown in figure A-11. *Be careful not to score or scratch the sealing surface during the installation.* Install the bearing cap seal (15) and thrust washer (32) into their respective grooves on the bearing cap mounting surface as shown in figure A-11.
17. Coat the bearing cap seal area and pinion seal area shown in figure A-11 lightly with STP Oil Treatment.

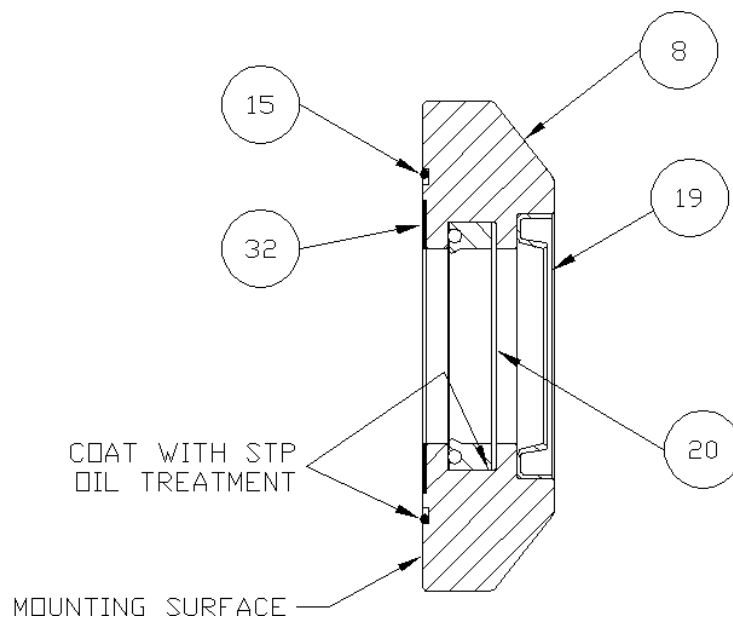

**figure A-11**

18. Wrap masking tape or electrical tape around the pinion to cover the edges at the keyway. Slide the bearing cap assembly over the pinion shaft with the bearing cap seal facing toward the actuator body and the flat surface of the flange shown in figure A-16 facing toward the actuator mounting flanges. Press against the bearing cap until the shoulder seats against the actuator body, making sure that the seals remain in place. Install the bearing cap bolts (21) (fig. A-13) and lock washers (25). Hand tighten only at this time. Repeat this procedure for other bearing cap.

19. After both bearing caps have been installed, torque all bearing cap bolts to 30 ft-lb. in the sequence shown in figure A-12.

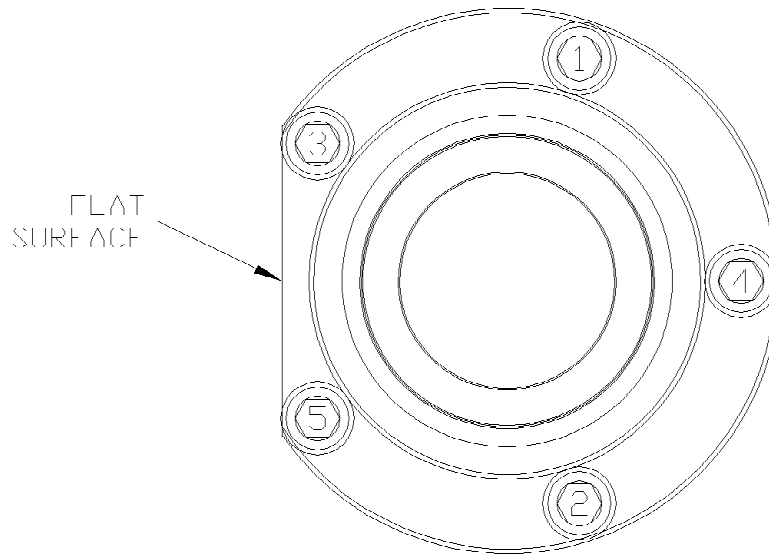

**figure A-12**

20. Install the 90° fitting (27) (fig. A-13) into the oil port on the side of the rack cap (5). Hand tighten only at this time.
21. Install the 45° bulk-head fitting (31) (fig. A-13) up through the hole in the tube mounting bracket (30) bolted to the tube cap as shown in figure A-13. The 45° end must be pointing down away from the rack cap (5) and back toward the mounting flanges on the actuator body. Hand tighten only at this time.
22. Install the rack cap extension tube assembly (29) (fig. A-13) between the 90° fitting in the rack cap and the 45° fitting in the tube mounting bracket as shown in figure A-13. Tighten all connections.
23. Install the orifice plug (11) (fig. A-13) into the oil port on the side of the tube cap (4), and install the 90° fitting (27) into the oil port over the orifice plug as shown in figure A-13. Turn the fitting so that it points down away from the rack cap (5) and back toward the mounting flanges on the actuator body and tighten.
24. Install the cap nuts (28) (fig. A-13) onto the open fittings to prevent contamination of the unit until the hoses are installed.

# ACTUATOR ASSEMBLY

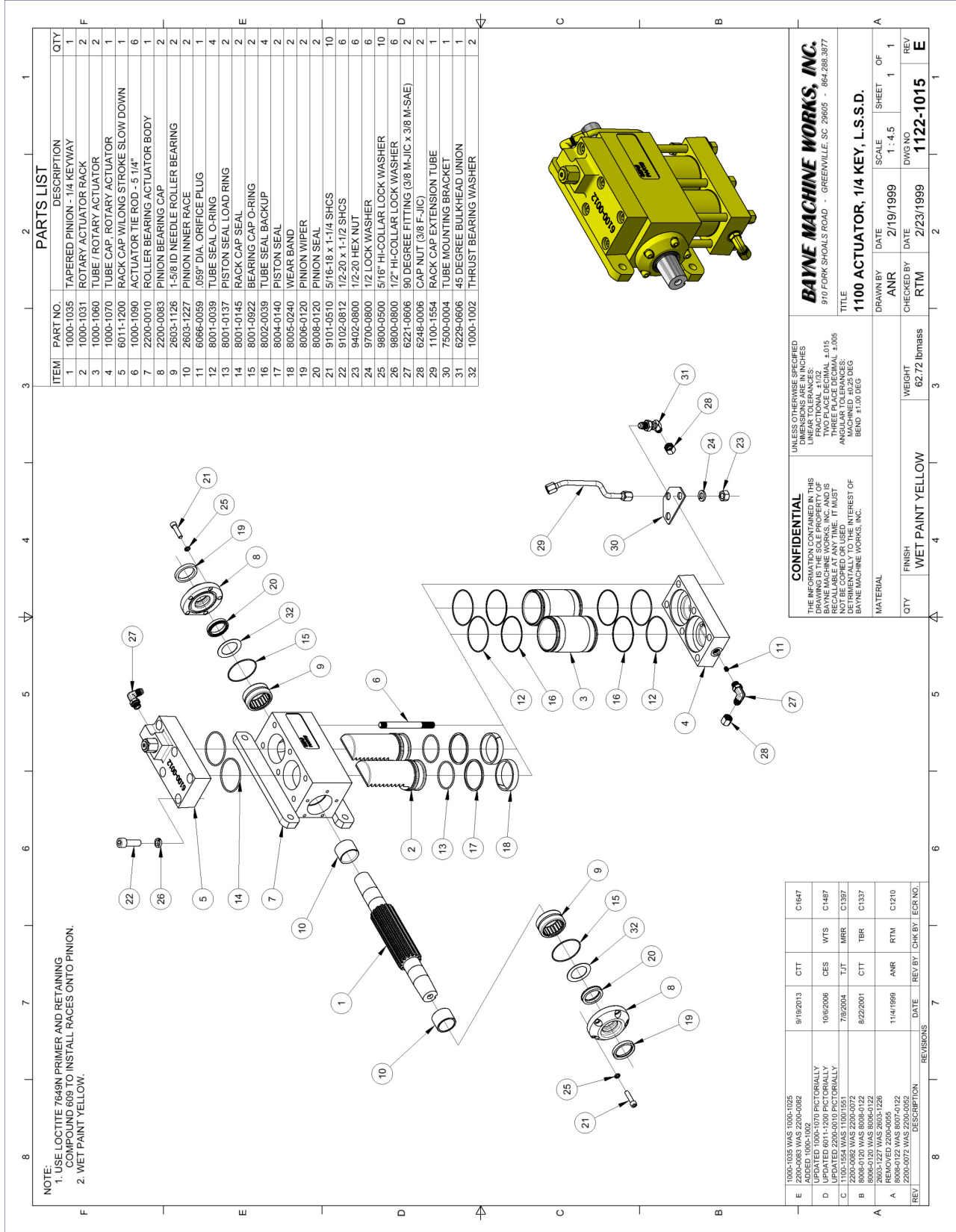

figure A-13

# ***BAYNE***

## **PREMIUM LIFT SYSTEMS**

### **ASSEMBLY INSTRUCTIONS**

#### **LONG STROKE SLOWDOWN**

PART NUMBER 6011-1200 ( WI-2301-A )

**LICENSED UNDER ONE OR MORE OF THE FOLLOWING U.S. PATENTS:**

**4,773,812      1,327,765      5,308,211      5,333,984**

#### **READ INSTRUCTIONS COMPLETELY BEFORE STARTING ASSEMBLY.**

The Slowdown is a patented device used to cushion the unit as it completes its rotation into the dump position. This cushioning prevents the tearing of carts and helps protect the dumper from abuse. The Slowdown is part of the Actuator assembly and is assembled into the rack cap.

Before starting the assembly of the Slowdown, refer to the exploded parts drawing ( figure S-4 ) and parts list to familiarize yourself with the individual components. Prepare a clean surface in an area free from blowing dust and contaminants in which to assemble the Slowdown. Be sure that all parts are clean and dry before starting assembly. NOTE: All torque values given apply to clean dry threads only. Follow these directions when assembling the Slowdown:

1. Install the housing seal ( 5 ) ( figure S-1 ) in the groove next to the hexagon head of the plunger housing ( 1 ). Place the square backup ring ( 7 ) in the groove at the end of the plunger housing ( 1 ). Place the o-ring ( 6 ) in the same groove as the square backup ring ( 7 ) closest to the hexagon head of the plunger housing ( 1 ).

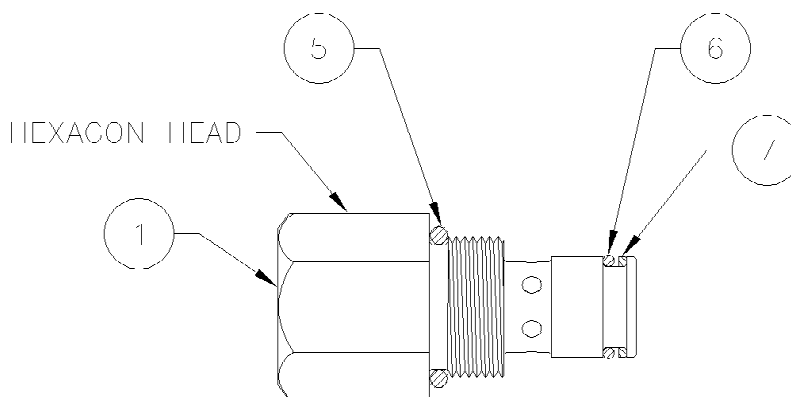

**figure S-1**

2. Place the plunger ( 2 ) ( figure S-2 ) into the plunger housing ( 1 ). Place the spring ( 4 ) on top of the plunger ( 2 ). Coat the o-ring on the o-ring plug ( 9 ) with STP Oil Treatment. Screw the o-ring plug ( 9 ) into the plunger housing ( 1 ) on top of the spring ( 4 ) and tighten to 30 in-lb. torque.

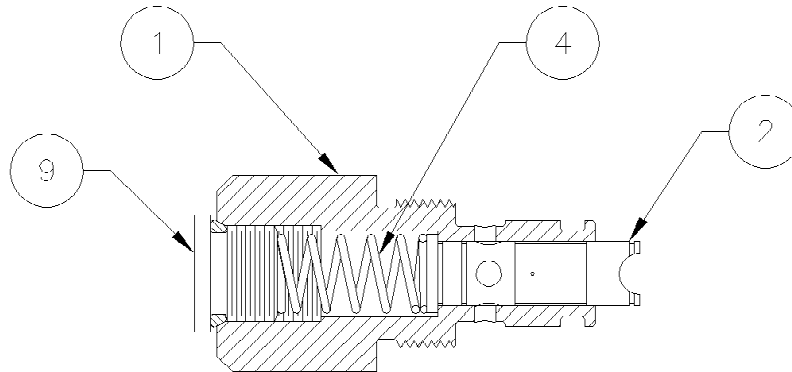

**figure S-2**

3. Coat the o-rings on the plunger housing ( 1 ) ( figure S-3 ) and the o-ring on the o-ring plug ( 8 ) with STP Oil Treatment. Screw the plunger housing ( 1 ) into the top of the rack cap ( 3 ) ( figure S-4 ) and tighten. Screw the o-ring plug ( 8 ) into the side of the rack cap ( 3 ) in the bottom port and tighten.

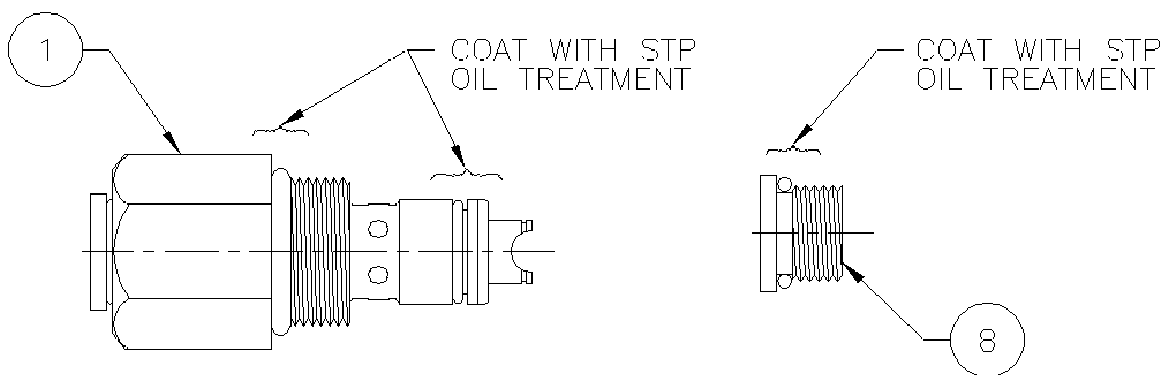

**figure S-3**

# SLOWDOWN ASSEMBLY LONG STROKE PART NO. 6011-1200

| ITEM NO | PART NO.  | DESCRIPTION                      | QTY |
|---------|-----------|----------------------------------|-----|
| 1       | 6100-0011 | PLUNGER HOUSING                  | 1   |
| 2       | 6100-0006 | VALVE-PLUNGER-LONG STROKE        | 1   |
| 3       | 6100-0012 | RACK CAP- SOFT START/SLOW DOWN   | 1   |
| 4       | 3400-0020 | SPRING-SLOWDOWN/SOFT START VALVE | 1   |
| 5       | 8001-0910 | O-RING                           | 1   |
| 6       | 8001-0014 | O-RING                           | 1   |
| 7       | 8002-4014 | BACK-UP WASHER                   | 1   |
| 8       | 6246-0004 | PLUG (ST. THREAD HOLLOW HEX)     | 1   |
| 9       | 6246-0006 | PLUG (ST. THREAD HOLLOW HEX)     | 1   |
| 10      | 6011-1214 | LONG STROKE SLOW DOWN ASSEMBLY   | 1   |

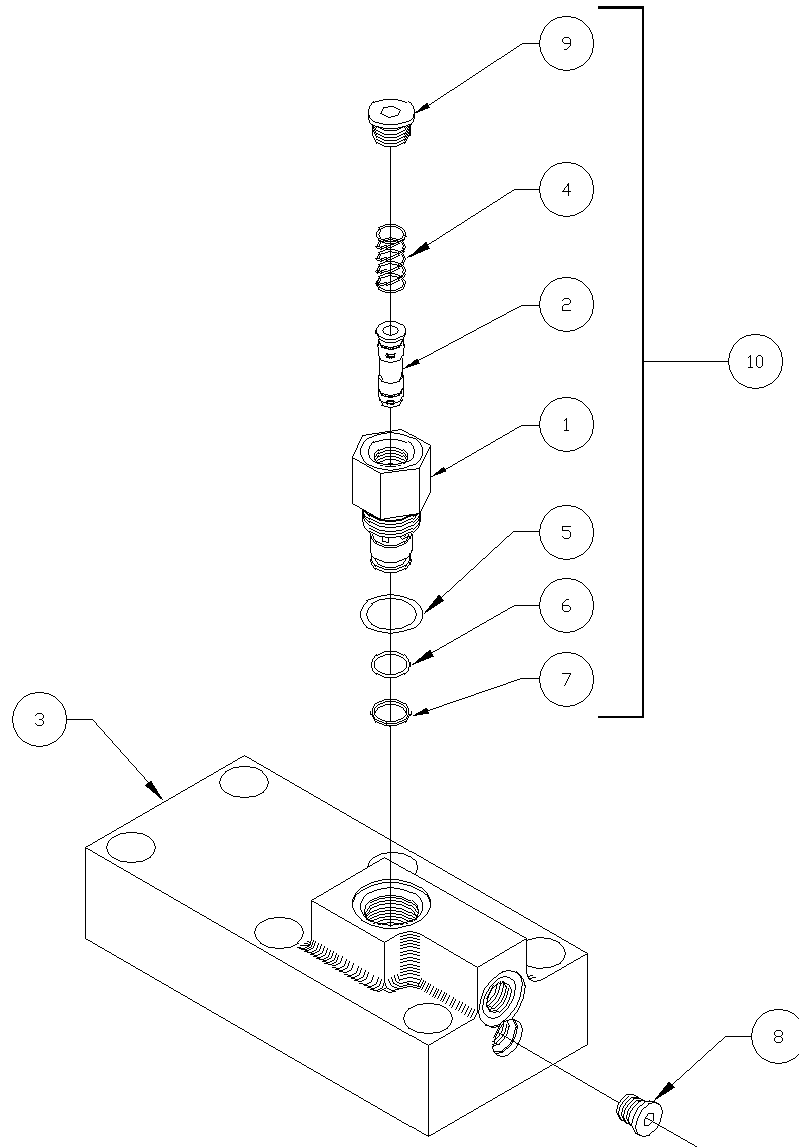

**figure S-4**

## TROUBLE-SHOOTING CHART ( WI-0308-A )

| <i>SYMPTOM</i>                                | <i>POSSIBLE CAUSES</i>  | <i>CORRECTIVE ACTION</i>   |
|---|---|--|
| Lifter operation very erratic.                | <ol style="list-style-type: none"> <li>1. Air trapped in system.</li> <li>2. Low oil level.</li> </ol>  | <ol style="list-style-type: none"> <li>1. Bleed all air from lifter hydraulic system.</li> <li>2. Add oil to system.</li> </ol>  |
| Cart lifter will not pick up carts.           | <ol style="list-style-type: none"> <li>1. Cart overweight.</li> <li>2. Lifter system hydraulic pressure too low.</li> <li>3. Truck system hydraulic pressure too low.</li> <li>4. Faulty hand valve.</li> </ol> | <ol style="list-style-type: none"> <li>1. Reduce loaded weight of cart.</li> <li>2. Check and adjust pressure relief on hand valve.</li> <li>3. Check and adjust pressure on truck system relief.</li> <li>4. Replace hand valve.</li> </ol> |
| Lifter operates extremely slow.               | <ol style="list-style-type: none"> <li>1. Engine idle too low.</li> <li>2. Faulty hand valve.</li> <li>3. Low hydraulic flow to lifter circuit.</li> <li>4. Faulty truck hydraulic pump.</li> </ol>             | <ol style="list-style-type: none"> <li>1. Adjust engine idle.</li> <li>2. Replace hand valve.</li> <li>3. Check truck's hydraulic system flow.</li> <li>4. Consult truck maintenance manual.</li> </ol>                                      |
| Lifter operates under recommended cycle time. | <ol style="list-style-type: none"> <li>1. Engine idle too high.</li> <li>2. High hydraulic flow to lifter circuit.</li> </ol>   | <ol style="list-style-type: none"> <li>1. Adjust engine idle.</li> <li>2. Check truck's hydraulic system flow.</li> </ol>  |



## TROUBLE-SHOOTING CHART ( WI-0308-A )

| <i>SYMPTOM</i>   | <i>POSSIBLE CAUSES</i>                                     | <i>CORRECTIVE ACTION</i>   |
|--|--|--|
| Actuator leaking oil around pinion shaft.              | 1. Worn pinion shaft seals.                                | 1. Install pinion seal kit.  |
| Actuator leaking oil around piston tubes or rack cap.  | 1. Worn seals in actuator.                                 | 1. Install actuator seal kit.  |
| Cylinder leaking around rod.                           | 1. Worn cylinder rod seal.                                 | 1. Install cylinder seal kit.  |
| Grabber arms rotate down but will not clamp.           | 1. Sequence valve in port "CT4" pressure setting too high. | 1. Adjust pressure setting per Installation Instructions of this manual. |
| Grabber arms try to clamp before fully rotating down.  | 1. Sequence valve in port "CT4" pressure setting too low.  | 1. Adjust pressure setting per Installation Instructions of this manual. |
| Grabber arms unclamp but will not rotate up.           | 1. Sequence valve in port "CT1" pressure setting too high. | 1. Adjust pressure setting per Installation Instructions of this manual. |
| Grabber arms try to rotate up before fully unclamping. | 1. Sequence valve in port "CT1" pressure setting too low.  | 1. Adjust pressure setting per Installation Instructions of this manual. |
| Valve settings quit working after a period of time.    | 1. Valves were adjusted with cool oil temperature.         | 1. Adjust valves with oil at operating temperature.                      |

## TROUBLE-SHOOTING CHART ( WI-0308-A )

| <i><b>SYMPTOM</b></i>                          | <i><b>POSSIBLE CAUSES</b></i>   | <i><b>CORRECTIVE ACTION</b></i>  |
|--|---|--|
| Lifter looses carts when dumping.              | <ol style="list-style-type: none"> <li>1. Clamping pressure setting too low.</li> <li>2. Cart sides are too weak.</li> </ol>            | <ol style="list-style-type: none"> <li>1. Adjust clamping pressure setting per Installation Instructions of this manual.</li> <li>2. Replace cart.</li> </ol>  |
| Lifter crushes carts when dumping.             | <ol style="list-style-type: none"> <li>1. Clamping pressure setting too high.</li> <li>2. Cart sides are too weak.</li> </ol>           | <ol style="list-style-type: none"> <li>1. Adjust pressure setting per Installation Instructions of this manual.</li> <li>2. Replace cart.</li> </ol>   |
| Connecting rod frequently breaking or bending. | <ol style="list-style-type: none"> <li>1. Width dimension out of adjustment.</li> <li>2. Clamping pressure setting too high.</li> </ol> | <ol style="list-style-type: none"> <li>1. Adjust unclamped width dimension per Operation Instructions of this manual.</li> <li>2. Adjust pressure setting per Installation Instructions of this manual.</li> </ol> |

**APPENDIX A**  
Assembly drawings and part numbers

| ITEM NO. | PART NO.  | DESCRIPTION                         | QTY |
|----------|-----------|-------------------------------------|-----|
| 1        | 1122-1015 | 1100 ACTUATOR (Ø.059" DRIFTED) LSSD | 1   |
| 2        | 2000-1131 | 21" GTL MAINFRAME                   | 1   |
| 3        | 2000-1230 | TORQUE BEARING ASSEMBLY             | 2   |
| 4        | 2000-1302 | UPPER IDLER BEARING ASSEMBLY        | 2   |
| 5        | 2000-1338 | LOWER IDLER BEARING ASSEMBLY        | 2   |
| 6        | 3012-1026 | ROTATE CYLINDER                     | 1   |
| 7        | 3012-1028 | CLAMP CYLINDER                      | 1   |
| 8        | 4014-1200 | 14" TORQUE ARM (L.H.)               | 1   |
| 9        | 4014-1207 | 14" TORQUE ARM (R.H.)               | 1   |
| 10       | 4014-1328 | 14" IDLER ARM (R.H.)                | 1   |
| 11       | 4014-1329 | 14" IDLER ARM (L.H.)                | 1   |
| 12       | 4015-1924 | 1/2" CONNECTING ROD                 | 1   |
| 13       | 4800-0000 | GTL FACE PLATE                      | 1   |
| 14       | 4800-0008 | SHAFT BEARING MOUNT ASSEMBLY        | 2   |
| 15       | 4800-0009 | HOSE PROTECTOR BRACKET              | 1   |
| 16       | 4800-0011 | GTL CLAMP ARM ASSEMBLY              | 2   |
| 17       | 4800-0029 | GTL ARM PIN                         | 2   |
| 18       | 4800-0030 | GTL CLAMP ARM SHAFT                 | 1   |
| 19       | 4800-0037 | BRONZE THRUST WASHER                | 4   |
| 20       | 4800-0038 | SHAFT COLLAR                        | 2   |
| 21       | 4800-0039 | CLAMP ARM BEARING COVER             | 4   |
| 22       | 4800-0045 | GTL MANIFOLD MOUNTING BRACKET       | 1   |
| 23       | 5000-0010 | WARNING LABEL                       | 1   |
| 24       | 5000-0077 | NOTICE LABEL                        | 1   |
| 25       | 6088-0017 | GTL MANIFOLD ASSEMBLY               | 1   |
| 26       | 6221-0404 | 90° ADAPTER (#4 SAE x #4 JIC)       | 9   |
| 27       | 6222-0404 | 90° LG. ADAPTER (#4 SAE x #4 JIC)   | 9   |
| 28       | 6420-0674 | HOSE ASSY Ø3/8" x 74" ST/ST         | 2   |
| 29       | 6427-0415 | HOSE ASSY Ø1/4" x 15" L.H. SPECIAL  | 1   |
| 30       | 6427-0416 | HOSE ASSY Ø1/4" x 15" R.H. SPECIAL  | 1   |
| 31       | 6427-0418 | HOSE ASSY Ø1/4" x 18" ST/ST         | 1   |
| 32       | 6427-0420 | HOSE ASSY Ø1/4" x 20" ST/ST         | 1   |
| 33       | 6427-4126 | HOSE ASSY Ø1/4" x 126" ST/ST        | 2   |
| 34       | 5530-0010 | HOSE CLAMP COVER PLATE              | 1   |
| 35       | 5530-0014 | 1/2" PLASTIC CLAMP                  | 2   |
| 36       | 7202-0800 | SPHERICAL ROD END                   | 2   |
| 37       | 7300-0410 | KEY Ø1/4" x 1 3/16" LG.             | 2   |
| 38       | 7500-0070 | MODEL/SERIAL NAME PLATE             | 1   |
| 39       | 7500-0071 | DRIVE SCREW                         | 4   |
| 40       | 7500-0080 | RUBBER BUMPER                       | 4   |
| 41       | 7500-0117 | TORQUE ARM WASHER                   | 2   |
| 42       | 7500-0171 | IDLER ARM WASHER                    | 2   |
| 43       | 7500-0206 | 5/8" CYLINDER BOSS SPACER           | 3   |
| 44       | 8110-0032 | CYLINDER PIVOT PIN                  | 1   |
| 45       | 8810-0307 | Ø3/32" x 3/4" COTTER PIN            | 2   |
| 46       | 8901-0500 | 5/16-18 SELF-LOCKING NUT            | 2   |
| 47       | 8901-0800 | 1/2-13 SELF-LOCKING NUT             | 2   |
| 48       | 9001-0406 | 1/4-20 x 3/4" HH.C.S.               | 2   |
| 49       | 9001-0514 | 5/16-18 x 1 3/4" HH.C.S.            | 1   |
| 50       | 9001-0530 | 5/16-18 x 3 3/4" HH.C.S.            | 2   |
| 51       | 9001-0608 | 3/8-16 x 1" HH.C.S.                 | 2   |
| 52       | 9001-0610 | 3/8-16 x 1 1/4" HH.C.S.             | 16  |
| 53       | 9001-0616 | 3/8-16 x 2" HH.C.S.                 | 2   |
| 54       | 9001-0808 | 1/2-13 x 1" HH.C.S.                 | 2   |
| 55       | 9001-0844 | 1/2-13 x 5 1/2" HH.C.S.             | 2   |
| 56       | 9101-0815 | GTL ROTATE BOLT (SPECIAL)           | 1   |
| 57       | 9101-0608 | 3/8-16 x 1" S.H.C.S.                | 10  |
| 58       | 9102-0304 | #10-32 x 1 1/2" S.H.C.S.            | 12  |
| 59       | 9201-0808 | 1/2-13 x 1" B.H.C.S.                | 2   |
| 60       | 9201-0812 | 1/2-13 x 1 1/2" B.H.C.S.            | 1   |
| 61       | 9201-1000 | 5/8-11 x 1 1/4" B.H.C.S.            | 2   |
| 62       | 9301-0604 | 3/8-16 x 1 1/2" SET SCREW           | 2   |
| 63       | 9402-0800 | 1/2-20 HALF NUT                     | 8   |
| 64       | 9502-0800 | 1/2-20 HALF NUT                     | 2   |
| 65       | 9521-0800 | 1/2-13 SELF-LOCKING JAM NUT         | 1   |
| 66       | 9600-0400 | 1/4" FLAT WASHER                    | 2   |
| 67       | 9600-0500 | 5/16" FLAT WASHER                   | 80  |
| 68       | 9600-0800 | 1/2" FLAT WASHER                    | 4   |
| 69       | 9600-1000 | 5/8" FLAT WASHER                    | 2   |

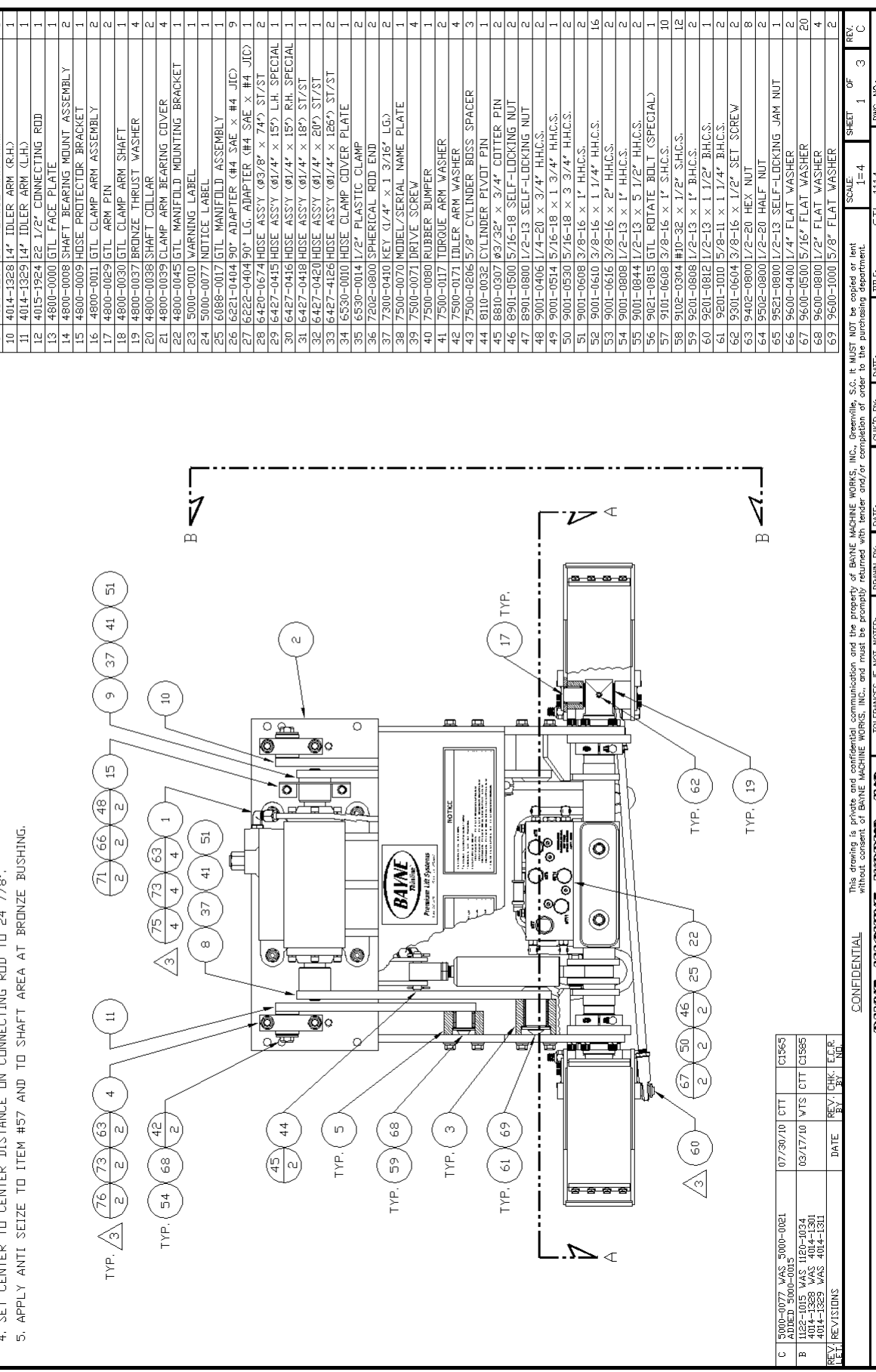

| ITEM NO. | PART NO.  | DESCRIPTION                   | QTY |
|----------|-----------|-------------------------------|-----|
| 70       | 9700-0300 | #10 LOCK WASHER               | 12  |
| 71       | 9700-0400 | 1/4" LOCK WASHER              | 2   |
| 72       | 9700-0600 | 3/8" LOCK WASHER              | 18  |
| 73       | 9700-0800 | 1/2" LOCK WASHER              | 8   |
| 74       | 9800-0600 | 3/8" HI-COLLAR LOCK WASHER    | 10  |
| 75       | 9902-0814 | 1/2-20 x 1 3/4" THREADED STUD | 4   |
| 76       | 9902-0830 | 1/2-20 x 3 3/4" THREADED STUD | 4   |
| 77       | 5000-0015 | BAYNE LOGO LABEL              | 1   |

|      |          |          |     |      |          |          |     |
|------|----------|----------|-----|------|----------|----------|-----|
| DATE | 07/17/03 | CHK'D BY | TJT | DATE | 08/26/07 | CHK'D BY | TJT |
| REV  | 1        | REV      | 1   | REV  | 1        | REV      | 1   |
| REV  | 2        | REV      | 2   | REV  | 2        | REV      | 2   |
| REV  | 3        | REV      | 3   | REV  | 3        | REV      | 3   |

|          |                 |       |   |    |   |
|----------|-----------------|-------|---|----|---|
| SCALE    | 1=4             | SHEET | 1 | OF | 3 |
| TITLE    | LIFTER ASSEMBLY |       |   |    |   |
| DWG. NO. | 1900-0514       |       |   |    |   |

CONFIDENTIAL

BAYNE MACHINE WORKS, INC. Greenville, S.C. It MUST NOT be copied or lent without consent of BAYNE MACHINE WORKS, INC. and must be promptly returned with tender and/or completion of order to the purchasing department.

810 FORT STOKES ROAD - GREENVILLE, SC 29615 - 864-255-3377

TOLERANCES: IF NOT NOTED:  
 0.000 ±0.005  
 0.000 ±0.015  
 0.000 ±0.020  
 0.000 ±0.030

REV. REVISIONS

| REV. | REVISIONS               | DATE     | REV. | CHK'D BY | REV.  | CHK'D BY |
|------|-------------------------|----------|------|----------|-------|----------|
| C    | 5000-0077 WAS 5000-0021 | 07/30/10 | CTT  | CL565    |       |          |
| B    | ADDED 5000-0015         |          |      |          |       |          |
|      | 1122-1015 WAS 1120-1034 | 03/17/10 | WTS  | CTT      | CL565 |          |
|      | 4014-1328 WAS 4014-1301 |          |      |          |       |          |
|      | 4014-1329 WAS 4014-1301 |          |      |          |       |          |

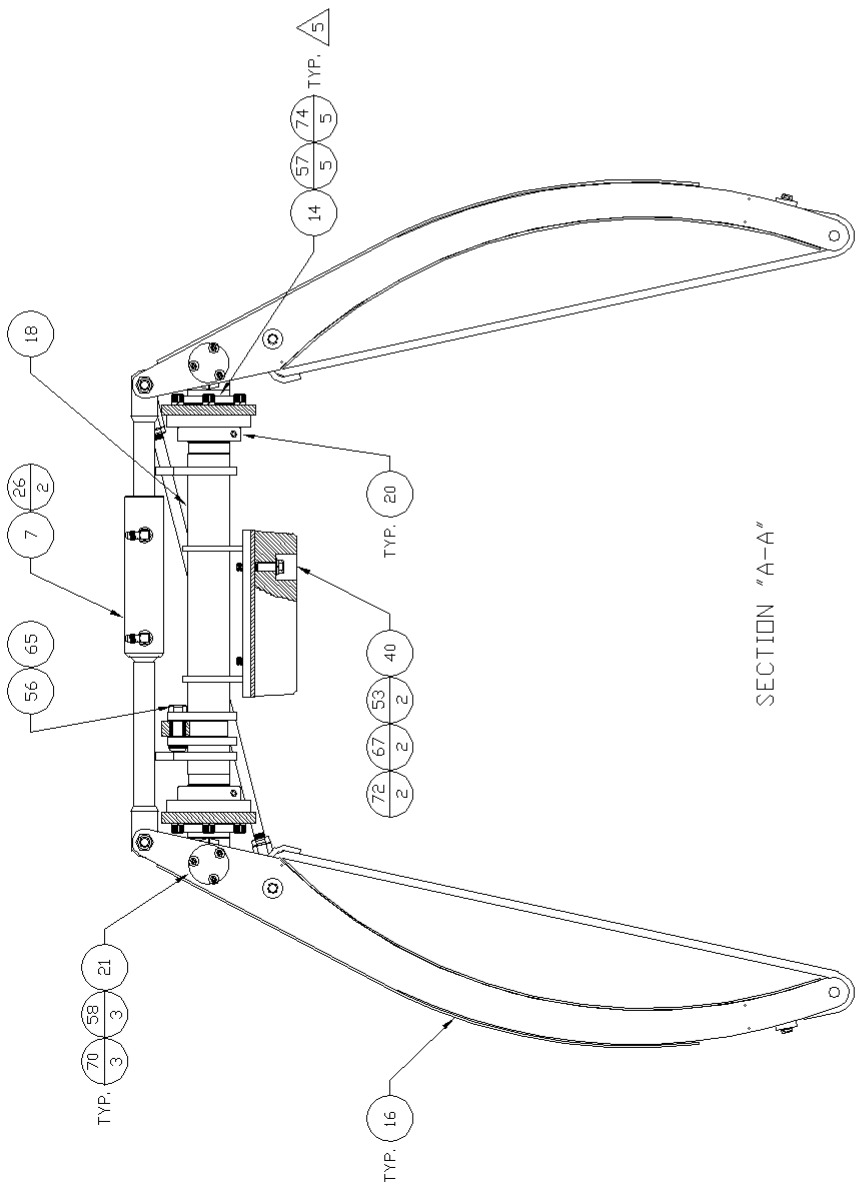

SECTION "A-A"

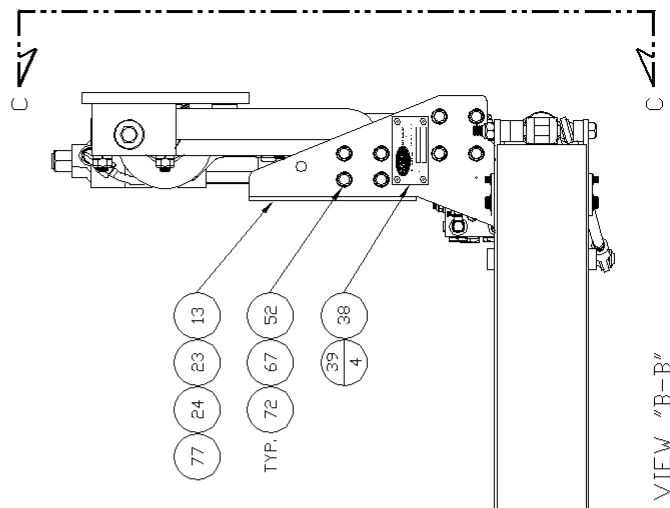

VIEW "B-B"

|   |  |   |                 |            |                        |                     |
|---|--|---|-----------------|------------|------------------------|---------------------|
| CONFIDENTIAL  |  | This drawing is private and confidential communication and the property of BAYNE MACHINE WORKS, INC., Greenville, S.C. It MUST NOT be copied or lent without consent of BAYNE MACHINE WORKS, INC., and must be promptly returned with tender and/or completion of order to the purchasing department. |                 | SCALE: 1=4 | SHEET 2 OF 3           | REV. C              |
| <b>BAYNE MACHINE WORKS, INC.</b><br>810 FORT BRIDGES ROAD - GREENVILLE, SC 29605 - 864-326-3377 |  | DATE: 07/17/03  | CHKD BY: T.J.T. | GT: 1114   | TITLE: LIFTER ASSEMBLY | DWG. NO.: 1900-0514 |
| TOLERANCES IF NOT NOTED:<br>0.005 ±0.005 - 0.00 ±0.015<br>0.0 ±0.1/0.2 - ANGULAR ±0.03          |  | DATE: 08/26/03  | CHKD BY: C.T.T. | GT: 1114   | TITLE: LIFTER ASSEMBLY | DWG. NO.: 1900-0514 |

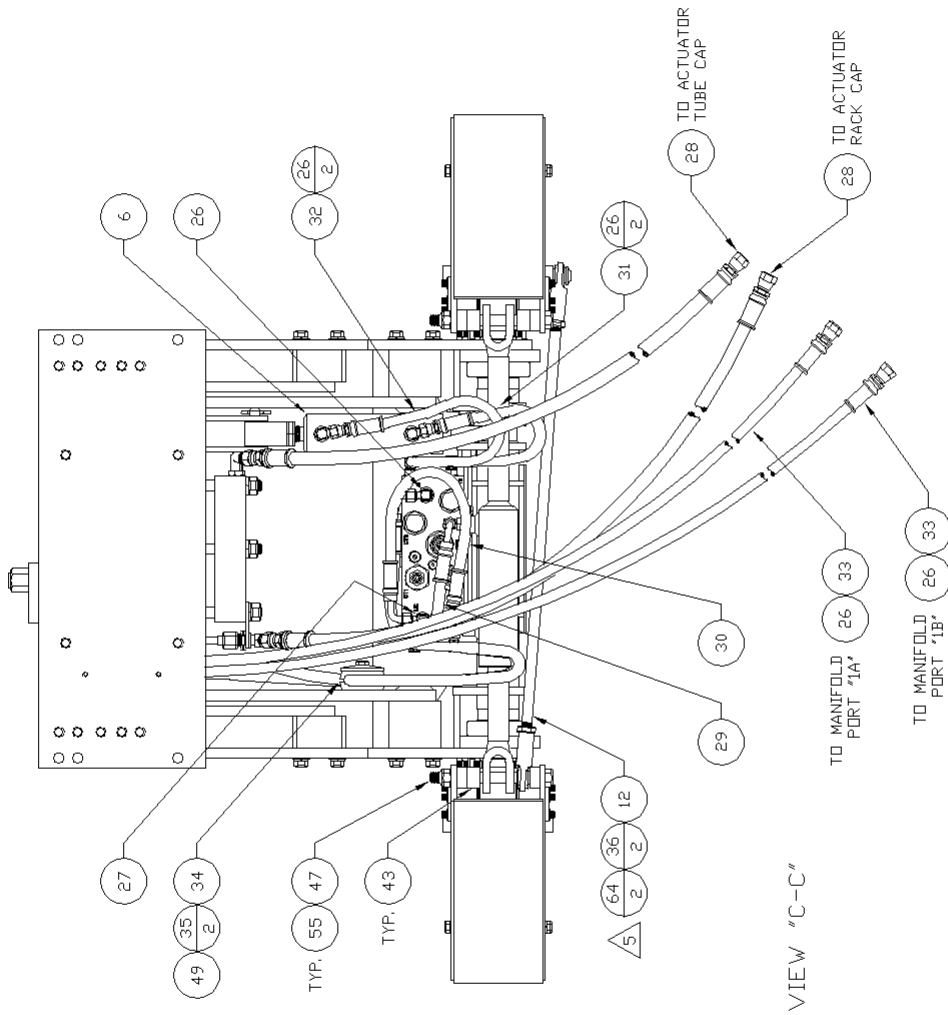

VIEW "C-C"

|   |   |  |                        |
|---|---|--|------------------------|
| CONFIDENTIAL<br>This drawing is private and confidential communication and the property of BAYNE MACHINE WORKS, INC., Greenville, S.C. It MUST NOT be copied or lent without consent of BAYNE MACHINE WORKS, INC., and must be promptly returned with tender and/or completion of order to the purchasing department. |   | SCALE: 1=4<br>GTL 1114<br>LIFTER ASSEMBLY  | SHEET 3 OF 3<br>REV. C |
| DRAWN BY: C.T.T.<br>DATE: 07/17/03<br>CHECKED BY: T.J.T.<br>DATE: 08/26/07  | TITLE: LIFTER ASSEMBLY<br>DWS. NO.: 1900-0514 | TOLERANCES UNLESS OTHERWISE SPECIFIED:<br>0.000 ± 0.005 - 0.00 ± 0.015<br>0.0 ± 0.002 - 0.00 ± 0.002 |                        |
| <b>BAYNE MACHINE WORKS, INC.</b><br>810 FORT BRIDGES ROAD - GREENVILLE, SC 29605 - 864-252-5377   |   |  |                        |

| ITEM NO. | PART NO.  | DESCRIPTION                    | QTY |
|----------|-----------|--------------------------------|-----|
| 1        | 2603-1115 | NEEDLE ROLLER BEARING          | 2   |
| 2        | 4800-0012 | GTL ARM WELDMENT               | 1   |
| 3        | 4800-0021 | GTL ARM BELT SQUISH PLATE      | 1   |
| 4        | 4800-0025 | GTL ARM BELT                   | 1   |
| 5        | 4800-0026 | GTL ARM TENSIONER              | 1   |
| 6        | 4800-0046 | GTL ARM BELT CLAMP             | 1   |
| 7        | 7002-0400 | 1/4-28 STRAIGHT GREASE FITTING | 2   |
| 8        | 8901-0600 | 3/8-16 SELF-LOCKING NUT        | 1   |
| 9        | 9001-0410 | 1/4-20 x 1 1/4" HHCS.          | 4   |
| 10       | 9001-0412 | 1/4-20 x 1 1/2" HHCS.          | 4   |
| 11       | 9401-0600 | 3/8-16 HEX NUT                 | 1   |
| 12       | 9700-0400 | 1/4" LOCK WASHER               | 4   |
| 13       | 6901-0400 | 1/4-20 SELF-LOCKING NUT        | 4   |

NOTE:  
 1. ALIGN OIL HOLE IN BEARING WITH GREASE FITTING HOLE AND PRESS FIT INTO ARM  
 2. ORIENT THICK RUBBER SIDE OF BELTING AWAY FROM ARM WELDMENT.

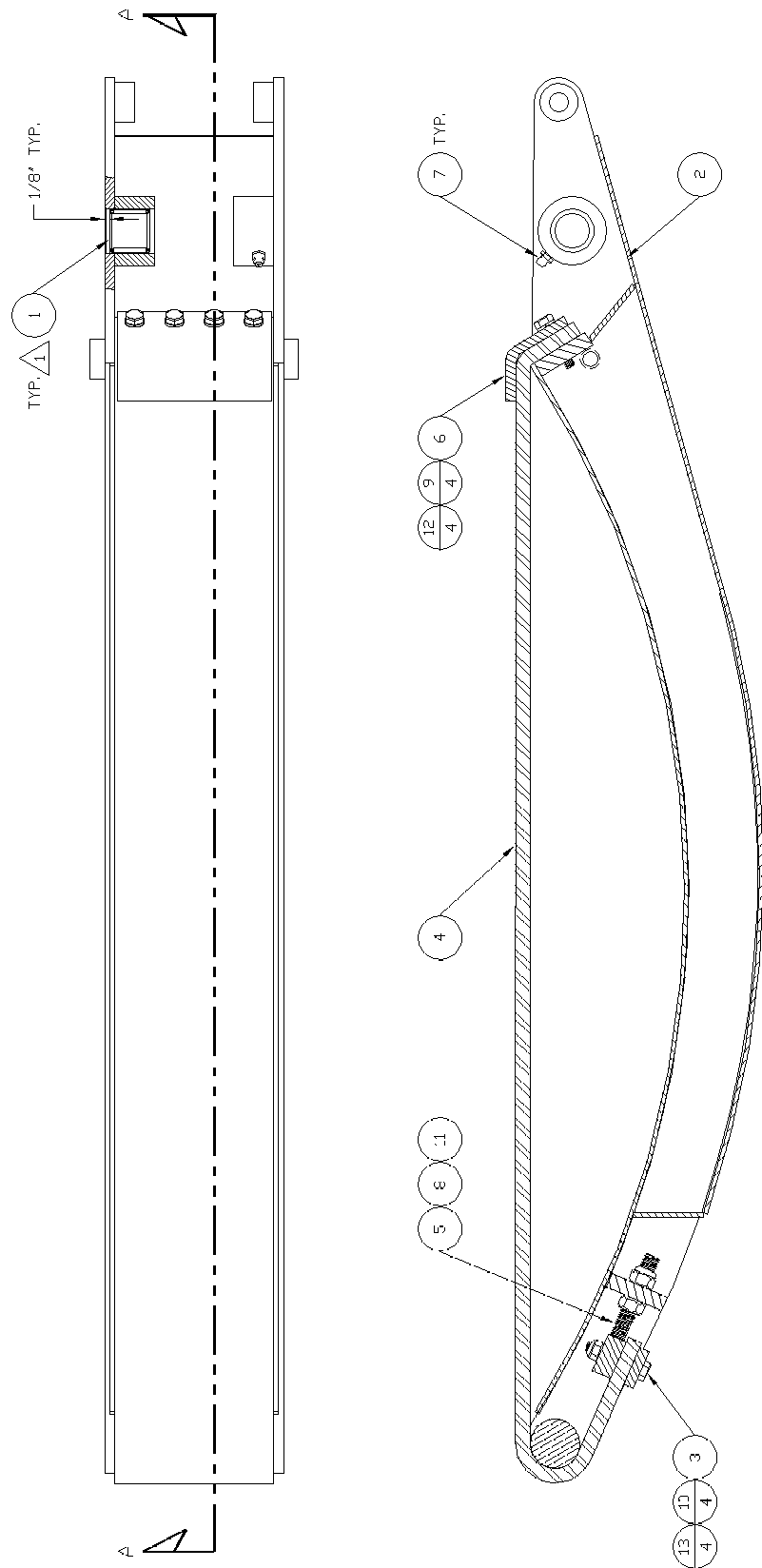

|     |                               |          |     |       |
|-----|-------------------------------|----------|-----|-------|
| C   | 9001-0412 WAS 9/05/04KE       | 11/17/02 | CTT | CL367 |
| B   | UPDATED 4800-0012 PICTOR-ALLY | 05/16/00 | CTT | TBR   |
| A   | ADDED 4800-0046               | 05/16/00 | CTT | TBR   |
| REV | ADDED NOTE 2                  | 05/16/00 | CTT | STW   |
| LET | REVISED                       | 05/16/00 | CTT | STW   |

SECTION "A-A"

|              |          |  |                  |
|--------------|----------|--|------------------|
| CONFIDENTIAL |          | TOLERANCES UNLESS OTHERWISE SPECIFIED:<br>0.004 FRACTIONS - ANGULAR 40:1 |                  |
| DATE         | 05/24/99 | CHKD BY  | RTM              |
| DATE         | 07/14/99 | TITLE  | GTL ARM ASSEMBLY |
| SCALE        | 1=2      | SHEET  | 1 OF 1           |
| REV.         | C        | DWG. NO.   | 4800-0011        |

| ITEM NO | PART NO.  | DESCRIPTION             | QTY |
|---------|-----------|-------------------------|-----|
| 1       | 2600-0011 | BRONZE BEARING          | 1   |
| 2       | 4800-0007 | GTL SHAFT BEARING MOUNT | 1   |

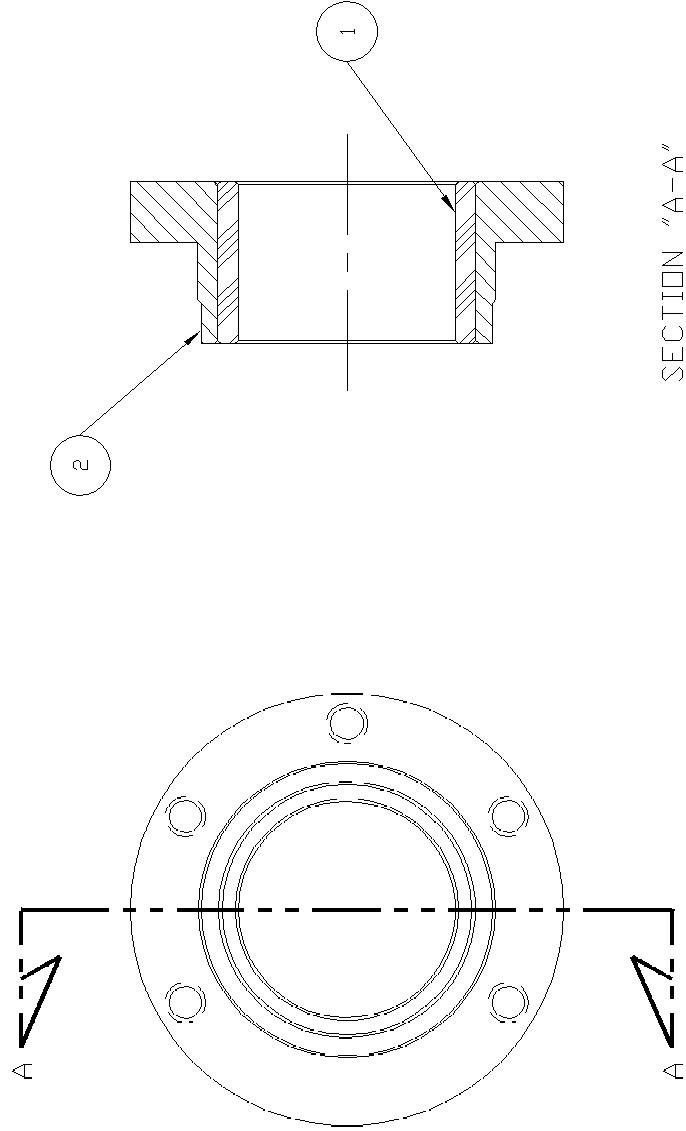

SECTION "A-A"

|  |  |                                      |       |                     |      |
|--|--|--------------------------------------|-------|---------------------|------|
| CONFIDENTIAL This drawing is private and confidential communication and the property of BAYNE MACHINE WORKS, INC., Greenville, S.C. It MUST NOT be copied or lent without consent of BAYNE MACHINE WORKS, INC., and must be promptly returned with tender and/or completion of order to the purchasing department. |  | SCALE:                               | SHEET | OF                  | REV. |
| <b>BAYNE MACHINE WORKS, INC.</b><br>90 - DRRK SHOA, S ROAD - GREENVILLE, SC 29635 - 664-2881-3377  |  | 1=1                                  | 1     | -                   | -    |
| TOLERANCES IF NOT NOTED:<br>DIMS = 0.005 - 0.000 - 0.010 - 5<br>H/C = 1/32 - ANGULAR ±0.25   |  | TITLE: GTL SHAFT BEARING MOUNT ASS'Y |       | DWG. NO.: 4800-0008 |      |
| DRAWN BY: C-T  |  | DATE: 11/30/98                       |       | CHKD BY:            |      |



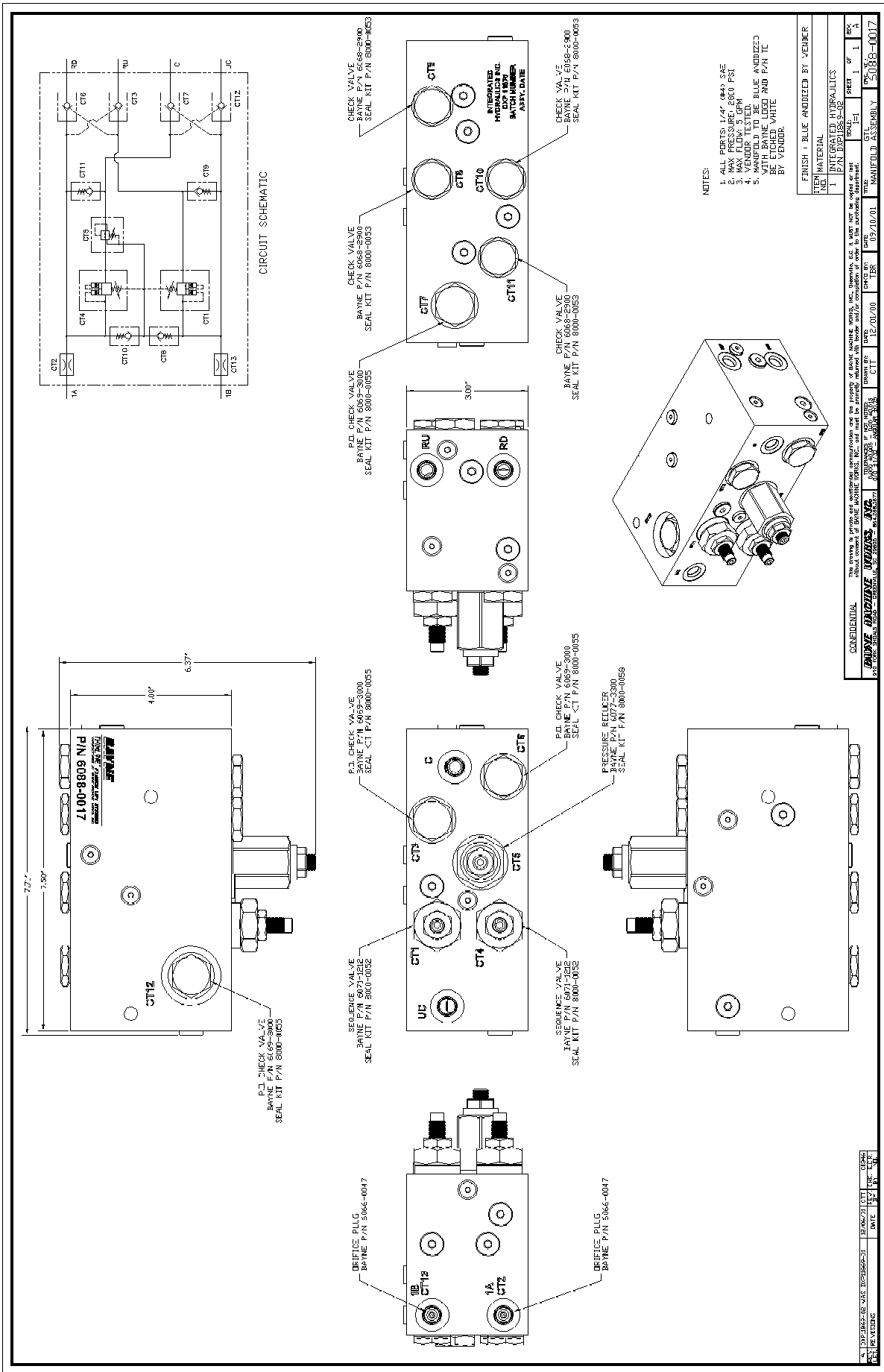

| ITEM | PART NO.  | DESCRIPTION             | QTY |
|------|-----------|-------------------------|-----|
| 1    | 3012-1025 | GTL ARM ROTATE CYLINDER | 1   |
| 2    | 4800-0010 | GTL ROTATE CYLINDER END | 1   |
| 3    | 2603-1406 | SLEEVE BUSHING          | 1   |

NOTE:  
 1. THREAD CYLINDER END ONTO THREADS UNTIL THE CORRECT DIMENSION IS ACQUIRED AND LOCK IN PLACE USING THE JAM NUT.

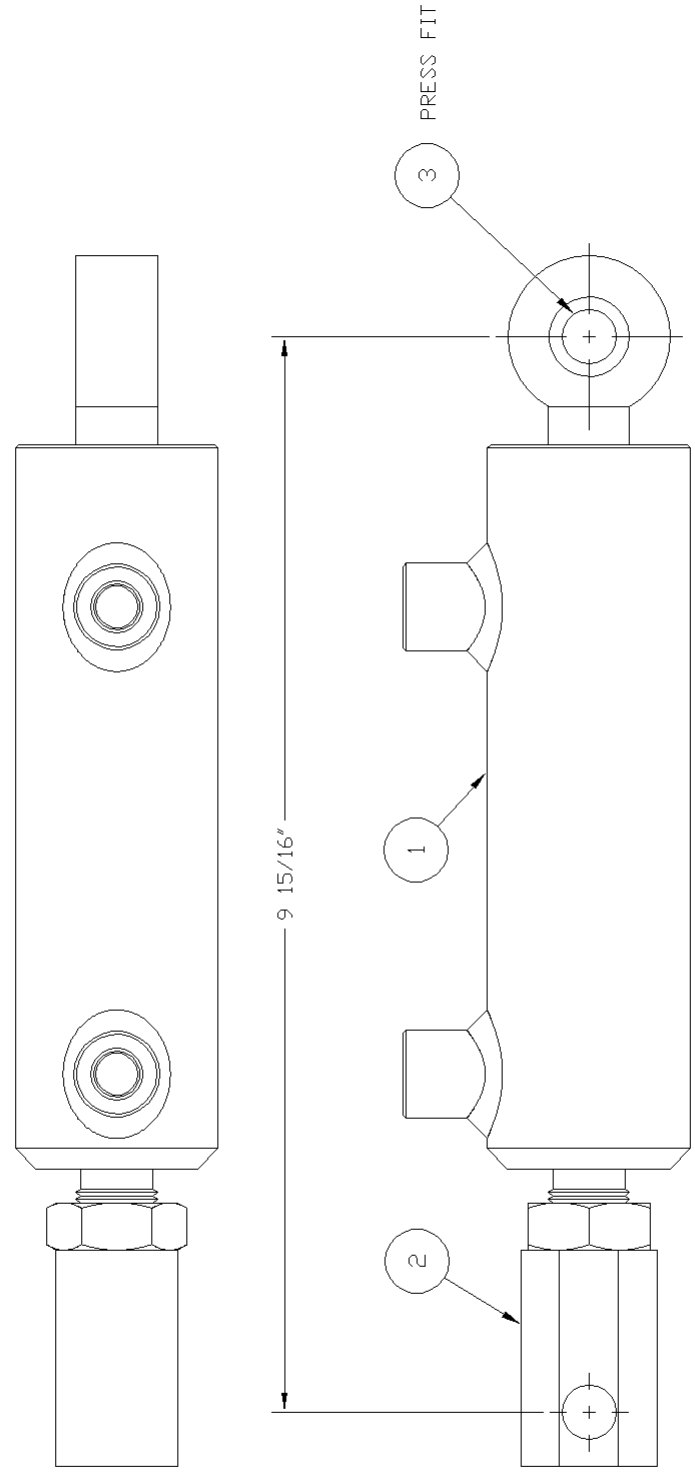

| REV. | DATE     | BY  | CHK. | E.C.R. |
|------|----------|-----|------|--------|
| C    | 12/10/09 | WTS | CTT  | CI580  |
| B    | 12/10/02 | WTS | CTT  | CI371  |
| A    | 09/16/02 | CTT | WTS  | CI358  |

CONFIDENTIAL This drawing is private and confidential communication and the property of BAYNE MACHINE WORKS, INC., Greenville, S.C. It MUST NOT be copied or lent without consent of BAYNE MACHINE WORKS, INC., and must be promptly returned with tender and/or completion of order to the purchasing department.

**BAYNE MACHINE WORKS, INC.**  
 910 FORK SHOALS ROAD - GREENVILLE, SC 29608 - 864.288.3877

TOLERANCES IF NOT NOTED:  
 0.000 ±0.005 - 0.000 ±0.015  
 0/0 ±1/32 - ANGULAR ±0.25

SCALE: 1=1 SHEET 1 OF 1 REV. C  
 DATE: 03/22/99 RTM DATE: 10/29/99 RTM  
 TITLE: GTL ARM ROTATE CYLINDER ASSEMBLY DWG. NO.: 3012-1026

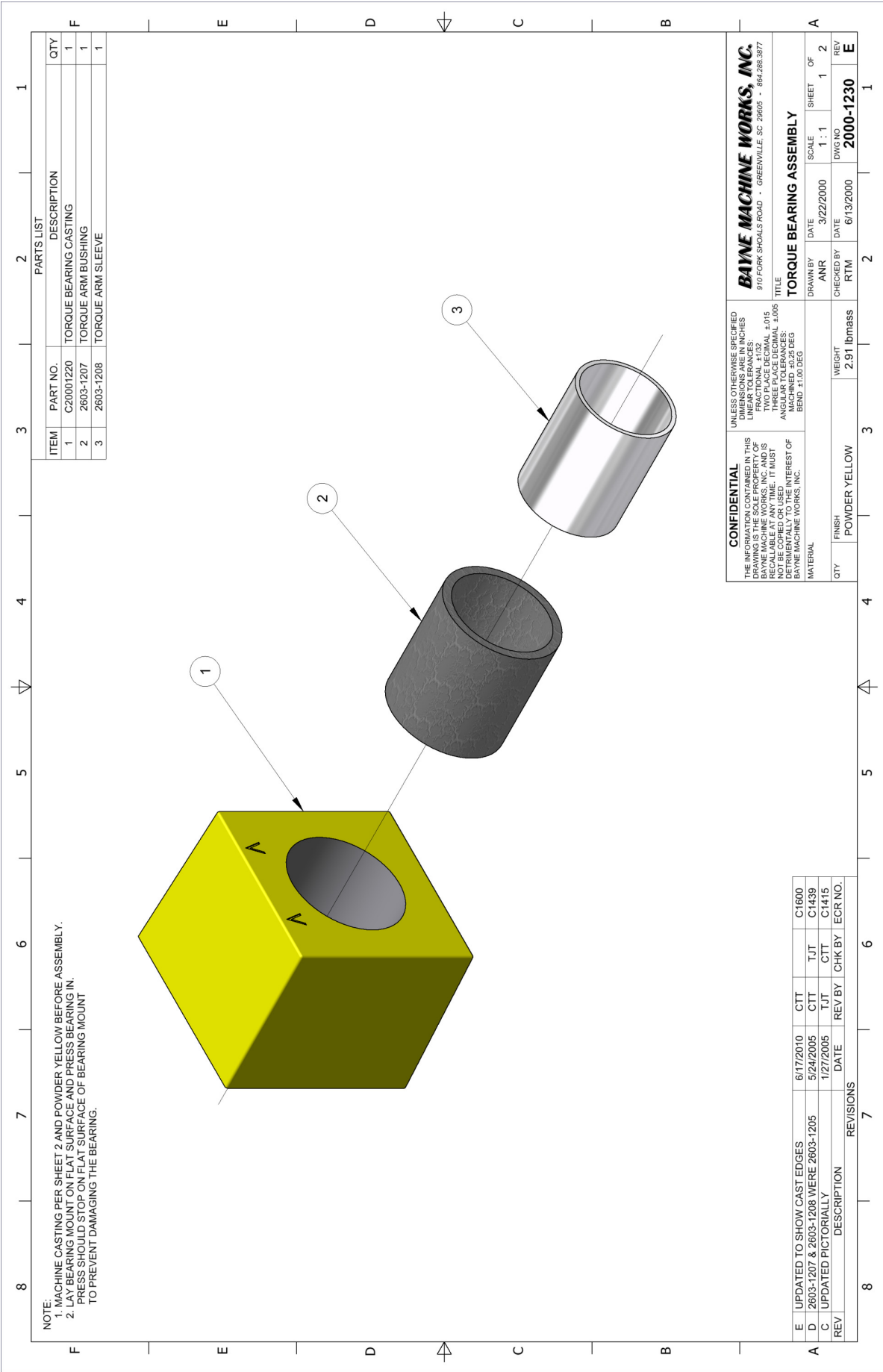

NOTE:  
 1. MACHINE CASTING PER SHEET 2 AND POWDER YELLOW BEFORE ASSEMBLY.  
 2. LAY BEARING MOUNT ON FLAT SURFACE AND PRESS BEARING IN.  
 PRESS SHOULD STOP ON FLAT SURFACE OF BEARING MOUNT  
 TO PREVENT DAMAGING THE BEARING.

| PARTS LIST |           |                        |     |
|------------|-----------|------------------------|-----|
| ITEM       | PART NO.  | DESCRIPTION            | QTY |
| 1          | C20001220 | TORQUE BEARING CASTING | 1   |
| 2          | 2603-1207 | TORQUE ARM BUSHING     | 1   |
| 3          | 2603-1208 | TORQUE ARM SLEEVE      | 1   |

**CONFIDENTIAL**  
 THE INFORMATION CONTAINED IN THIS DRAWING IS THE SOLE PROPERTY OF BAYNE MACHINE WORKS, INC. AND IS NOT TO BE REPRODUCED OR TRANSMITTED IN ANY FORM OR BY ANY MEANS, ELECTRONIC OR MECHANICAL, INCLUDING PHOTOCOPYING, RECORDING, OR BY ANY INFORMATION STORAGE AND RETRIEVAL SYSTEM. ANY UNAUTHORIZED USE OR REPRODUCTION OF THIS DRAWING IS STRICTLY PROHIBITED AND WILL BE DEEMED TO BE A VIOLATION OF THE PATENT RIGHTS OF BAYNE MACHINE WORKS, INC. IN THE EVENT OF A VIOLATION, THE USER SHALL BE RESPONSIBLE FOR ALL DAMAGES AND COSTS INCURRED BY BAYNE MACHINE WORKS, INC. IN THE EVENT OF A VIOLATION.

UNLESS OTHERWISE SPECIFIED DIMENSIONS ARE IN INCHES  
 DECIMALS TO TWO PLACES  
 FRACTIONAL  $\pm 1/32$   
 TWO PLACE DECIMAL  $\pm 0.015$   
 ANGULAR DIMENSIONS  $\pm 0.005$   
 ANGULAR TOLERANCES MACHINED  $\pm 0.25$  DEG BEND  $\pm 1.00$  DEG

**BAYNE MACHINE WORKS, INC.**  
 910 FORK SHOALS ROAD - GREENVILLE, SC 29605 - 864.298.3977

**TORQUE BEARING ASSEMBLY**

|          |           |            |     |        |           |    |   |
|----------|-----------|------------|-----|--------|-----------|----|---|
| DATE     | 3/22/2000 | SCALE      | 1:1 | SHEET  | 1         | OF | 2 |
| DRAWN BY | ANR       | CHECKED BY | RTM | DWG NO | 2000-1230 |    |   |
| DATE     | 6/13/2000 | REV        | E   |        |           |    |   |

MATERIAL: POWDER YELLOW  
 QTY: 2.91 lbmass  
 WEIGHT: 2.91 lbmass

| REV | DESCRIPTION                          | DATE      | REV BY | CHK BY | ECR NO. |
|-----|--------------------------------------|-----------|--------|--------|---------|
| E   | UPDATED TO SHOW CAST EDGES           | 6/17/2010 | CTT    | TJT    | C1600   |
| D   | 2603-1207 & 2603-1208 WERE 2603-1205 | 5/24/2005 | CTT    | TJT    | C1439   |
| C   | UPDATED PICTORIALY                   | 1/27/2005 | TJT    | CTT    | C1415   |

REVISIONS

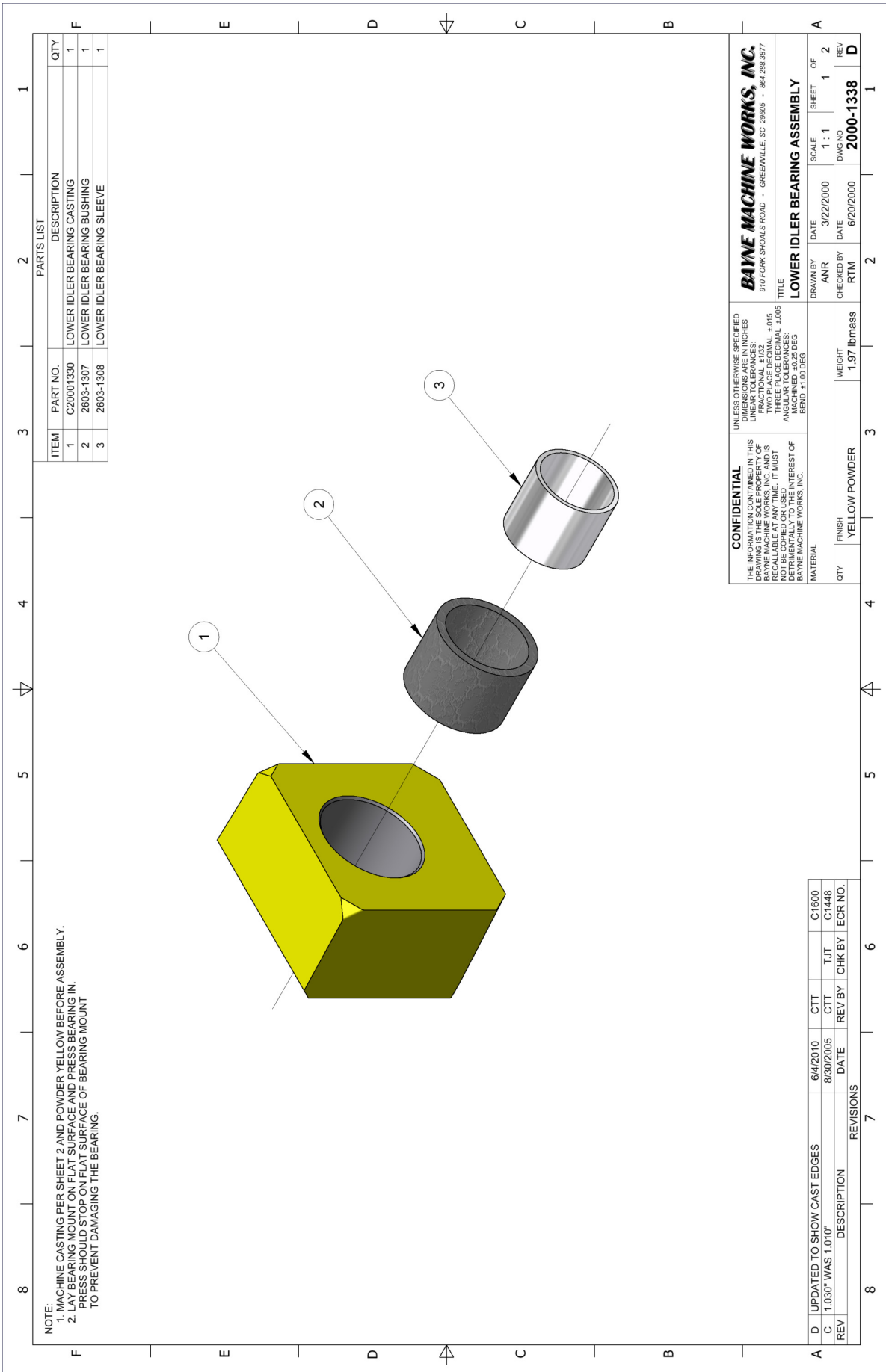

NOTE:  
 1. MACHINE CASTING PER SHEET 2 AND POWDER YELLOW BEFORE ASSEMBLY.  
 2. LAY BEARING MOUNT ON FLY SURFACE AND PRESS BEARING IN.  
 PRESS SHOULD STOP ON FLY SURFACE OF BEARING MOUNT  
 TO PREVENT DAMAGING THE BEARING.

| PARTS LIST |           |                             |     |
|------------|-----------|-----------------------------|-----|
| ITEM       | PART NO.  | DESCRIPTION                 | QTY |
| 1          | C20001330 | LOWER IDLER BEARING CASTING | 1   |
| 2          | 2603-1307 | LOWER IDLER BEARING BUSHING | 1   |
| 3          | 2603-1308 | LOWER IDLER BEARING SLEEVE  | 1   |

|   |  |   |  |
|---|--|---|--|
| <b>CONFIDENTIAL</b>   |  | UNLESS OTHERWISE SPECIFIED DIMENSIONS ARE IN INCHES<br>LINEAR DIMENSIONS FRACTIONAL ±1/32<br>TWO PLACE DECIMAL ±.015<br>ANGULAR DIMENSIONS ±.005<br>ANGULAR TOLERANCES MACHINED ±0.25 DEG<br>BEND ±1.00 DEG |  |
| THE INFORMATION CONTAINED IN THIS DRAWING IS THE SOLE PROPERTY OF BAYNE MACHINE WORKS, INC. AND IS NOT TO BE REPRODUCED OR TRANSMITTED IN ANY FORM OR BY ANY MEANS, ELECTRONIC OR MECHANICAL, INCLUDING PHOTOCOPYING, RECORDING, OR BY ANY INFORMATION STORAGE AND RETRIEVAL SYSTEM. ANY UNAUTHORIZED USE IS DETRIMENTAL TO THE INTEREST OF BAYNE MACHINE WORKS, INC. |  | TITLE<br><b>LOWER IDLER BEARING ASSEMBLY</b>  |  |
| MATERIAL<br>YELLOW POWDER   |  | DRAWN BY<br>ANR   |  |
| QTY<br>1  |  | DATE<br>3/22/2000   |  |
| FINISH<br>YELLOW POWDER   |  | CHECKED BY<br>RTM   |  |
| WEIGHT<br>1.97 lbmass   |  | DATE<br>6/20/2000   |  |
| SCALE<br>1:1  |  | SHEET<br>1  |  |
| DWG NO<br>2000-1338   |  | REV<br>D  |  |

| REV | DESCRIPTION                | DATE      | REV BY | CHK BY | ECR NO. |
|-----|----------------------------|-----------|--------|--------|---------|
| D   | UPDATED TO SHOW CAST EDGES | 6/4/2010  | CTT    | TJT    | C1600   |
| C   | 1.030" WAS 1.010"          | 8/30/2005 | CTT    | TJT    | C1448   |

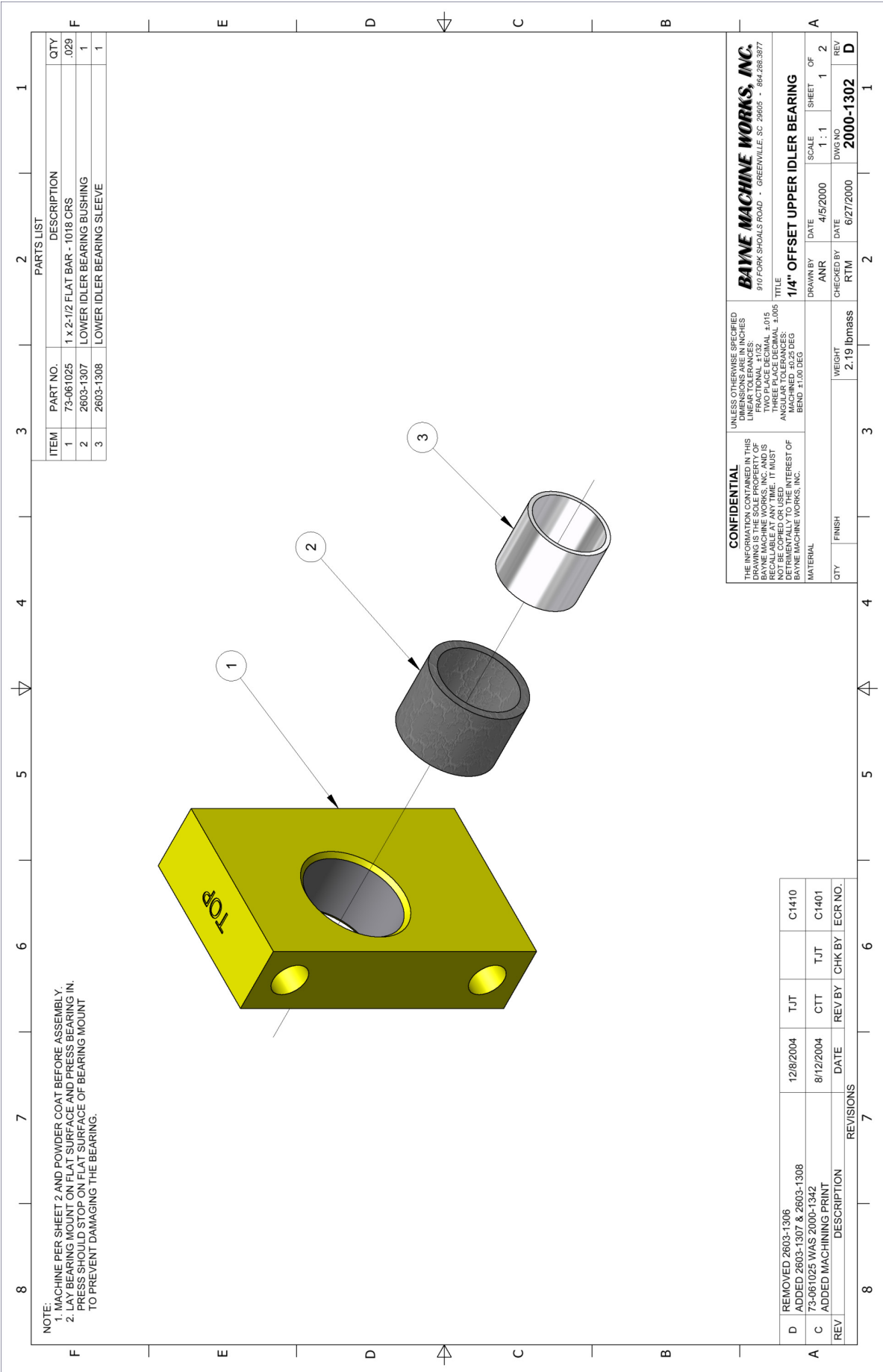

NOTE:  
 1. MACHINE PER SHEET 2 AND POWDER COAT BEFORE ASSEMBLY.  
 2. LAY BEARING MOUNT ON FLAT SURFACE AND PRESS BEARING IN.  
 PRESS SHOULD STOP ON FLAT SURFACE OF BEARING MOUNT  
 TO PREVENT DAMAGING THE BEARING.

| PARTS LIST |           |                               |      |
|------------|-----------|-------------------------------|------|
| ITEM       | PART NO.  | DESCRIPTION                   | QTY  |
| 1          | 73-061025 | 1 x 2-1/2 FLAT BAR - 1018 CRS | .029 |
| 2          | 2603-1307 | LOWER IDLER BEARING BUSHING   | 1    |
| 3          | 2603-1308 | LOWER IDLER BEARING SLEEVE    | 1    |

**CONFIDENTIAL**  
 THE INFORMATION CONTAINED IN THIS DRAWING IS THE SOLE PROPERTY OF BAYNE MACHINE WORKS, INC. AND IS NOT TO BE REPRODUCED OR TRANSMITTED IN ANY FORM OR BY ANY MEANS, ELECTRONIC OR MECHANICAL, INCLUDING PHOTOCOPYING, RECORDING, OR BY ANY INFORMATION STORAGE AND RETRIEVAL SYSTEM. WITHOUT THE WRITTEN PERMISSION OF BAYNE MACHINE WORKS, INC.

UNLESS OTHERWISE SPECIFIED DIMENSIONS ARE IN INCHES  
 LINE DECIMALS TO TWO PLACES  
 FRACTIONAL  $\pm 1/32$   
 TWO PLACE DECIMAL  $\pm 0.015$   
 ANGULAR DIMENSIONS  $\pm 0.005$   
 ANGULAR TOLERANCES  
 MACHINED  $\pm 0.25$  DEG  
 BEND  $\pm 1.00$  DEG

**BAYNE MACHINE WORKS, INC.**  
 910 FORK SHOALS ROAD - GREENVILLE, SC 29605 - 864.298.3977

TITLE  
**1/4" OFFSET UPPER IDLER BEARING**

|            |     |             |           |        |                  |       |   |    |   |
|------------|-----|-------------|-----------|--------|------------------|-------|---|----|---|
| DRAWN BY   | ANR | DATE        | 4/5/2000  | SCALE  | 1 : 1            | SHEET | 1 | OF | 2 |
| CHECKED BY | RTM | DATE        | 6/27/2000 | DWG NO | <b>2000-1302</b> |       |   |    |   |
| REV        |     | DESCRIPTION |           | WEIGHT | 2.19 lbmass      |       |   |    |   |
| REV        |     | DESCRIPTION |           | QTY    | FINISH           |       |   |    |   |

| REV | DESCRIPTION                 | DATE      | REV BY | CHK BY | ECR NO. |
|-----|-----------------------------|-----------|--------|--------|---------|
| D   | REMOVED 2603-1306           | 12/8/2004 | TJT    |        | C1410   |
| C   | ADDED 2603-1307 & 2603-1308 | 8/12/2004 | CTT    | TJT    | C1401   |
| A   | ADDED MACHINING PRINT       |           |        |        |         |

REVISIONS

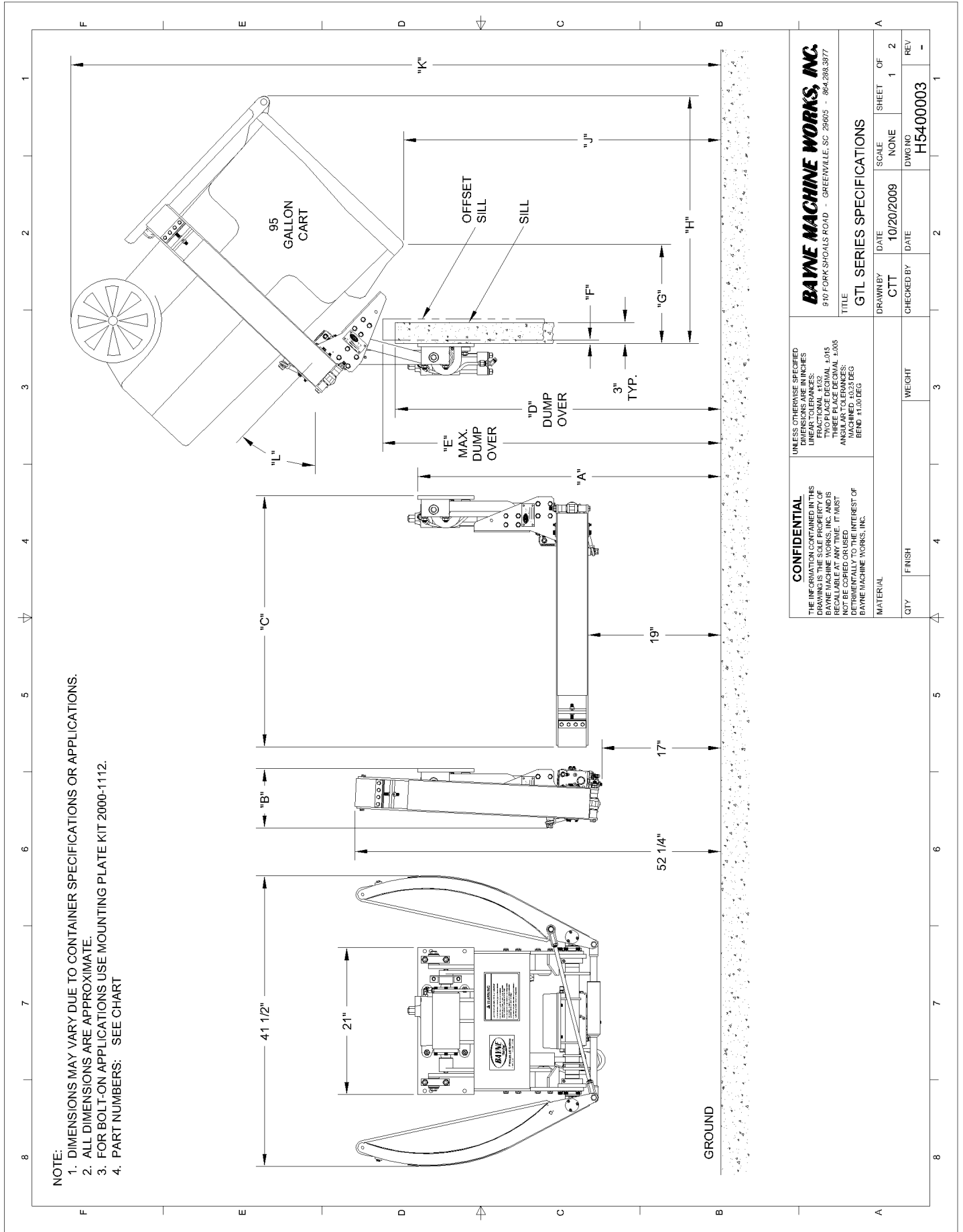

NOTE:  
 1. DIMENSIONS MAY VARY DUE TO CONTAINER SPECIFICATIONS OR APPLICATIONS.  
 2. ALL DIMENSIONS ARE APPROXIMATE.  
 3. FOR BOLT-ON APPLICATIONS USE MOUNTING PLATE KIT 2000-1112.  
 4. PART NUMBERS: SEE CHART

|   |        |   |                 |
|---|--------|---|-----------------|
| <b>CONFIDENTIAL</b>   |        | <b>UNLESS OTHERWISE SPECIFIED DIMENSIONS ARE IN INCHES LINEAR TOLERANCES:</b>                 |                 |
| THE INFORMATION CONTAINED IN THIS DRAWING IS THE PROPERTY OF BAYNE MACHINE WORKS, INC. AND IS NOT BE LOANED, REPRODUCED, COPIED, RECALLED AT ANY TIME, IT MUST NOT BE COPIED OR USED IN ANY MANNER DETRIMENTAL TO THE INTEREST OF BAYNE MACHINE WORKS, INC. |        | TWO PLACE DECIMAL ±.005<br>THREE PLACE DECIMAL ±.005<br>ANGULAR TOLERANCES:<br>BEND ±1.00 DEG |                 |
| MATERIAL  |        |   |                 |
| QTY   | FINISH | WEIGHT  |                 |
|   |        |   |                 |
| DRAWN BY CTT  |        | DATE 10/20/2009   | SCALE NONE      |
| CHECKED BY  |        | DATE  | SHEET 1 OF 2    |
|   |        |   | DWG NO H5400003 |
|   |        |   | REV -           |

**BAYNE MACHINE WORKS, INC.**  
 910 FORK SHOALS ROAD - GREENVILLE, SC 29605 - 864.288.3877

**GTL SERIES SPECIFICATIONS**

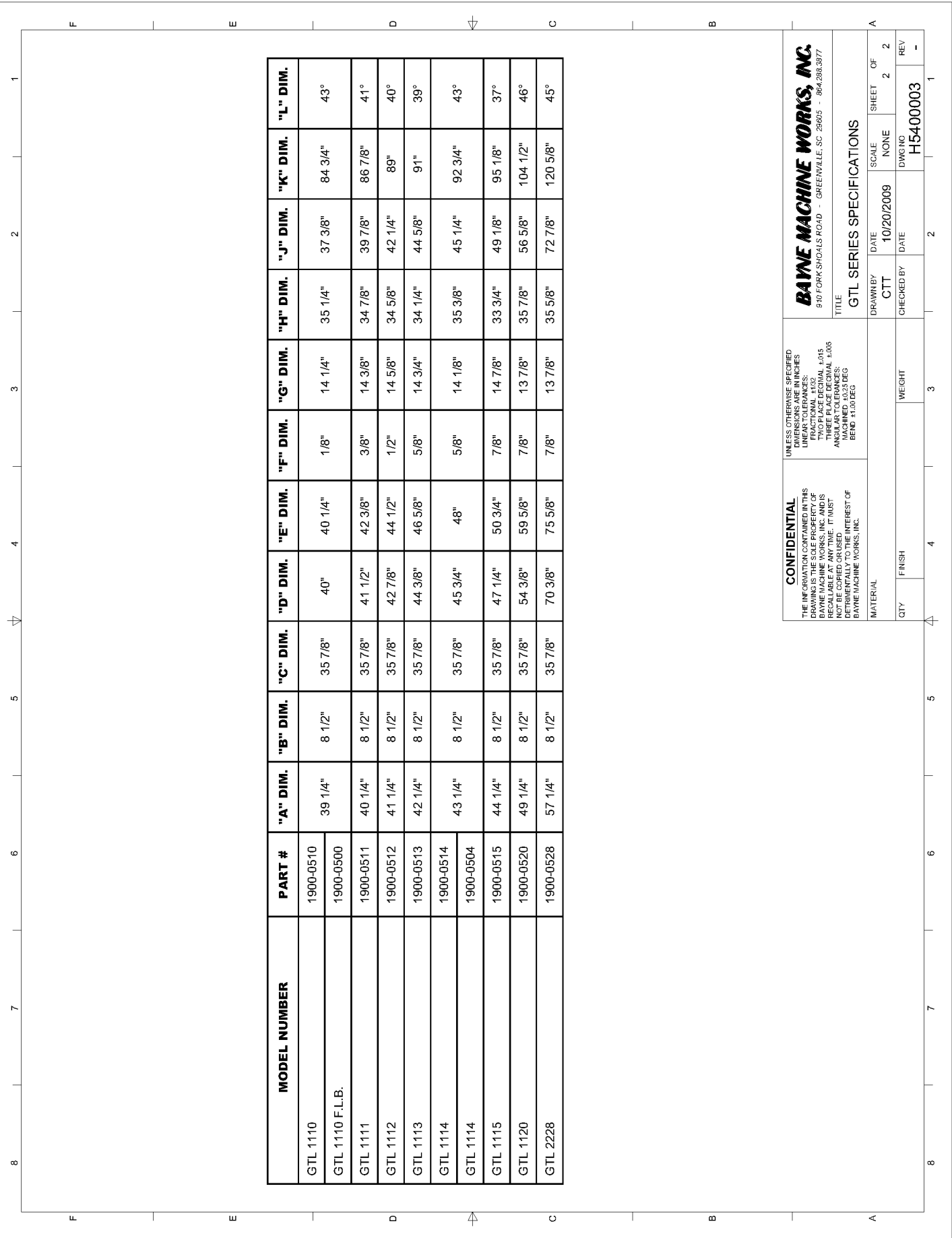

| MODEL NUMBER    | PART #    | "A" DIM. | "B" DIM. | "C" DIM. | "D" DIM. | "E" DIM. | "F" DIM. | "G" DIM. | "H" DIM. | "J" DIM. | "K" DIM. | "L" DIM. |
|-----------------|-----------|----------|----------|----------|----------|----------|----------|----------|----------|----------|----------|----------|
| GTL 1110        | 1900-0510 | 39 1/4"  | 8 1/2"   | 35 7/8"  | 40"      | 40 1/4"  | 1/8"     | 14 1/4"  | 35 1/4"  | 37 3/8"  | 84 3/4"  | 43°      |
| GTL 1110 F.L.B. | 1900-0500 |          |          |          |          |          |          |          |          |          |          |          |
| GTL 1111        | 1900-0511 | 40 1/4"  | 8 1/2"   | 35 7/8"  | 41 1/2"  | 42 3/8"  | 3/8"     | 14 3/8"  | 34 7/8"  | 39 7/8"  | 86 7/8"  | 41°      |
| GTL 1112        | 1900-0512 | 41 1/4"  | 8 1/2"   | 35 7/8"  | 42 7/8"  | 44 1/2"  | 1/2"     | 14 5/8"  | 34 5/8"  | 42 1/4"  | 89"      | 40°      |
| GTL 1113        | 1900-0513 | 42 1/4"  | 8 1/2"   | 35 7/8"  | 44 3/8"  | 46 5/8"  | 5/8"     | 14 3/4"  | 34 1/4"  | 44 5/8"  | 91"      | 39°      |
| GTL 1114        | 1900-0514 | 43 1/4"  | 8 1/2"   | 35 7/8"  | 45 3/4"  | 48"      | 5/8"     | 14 1/8"  | 35 3/8"  | 45 1/4"  | 92 3/4"  | 43°      |
| GTL 1114        | 1900-0504 |          |          |          |          |          |          |          |          |          |          |          |
| GTL 1115        | 1900-0515 | 44 1/4"  | 8 1/2"   | 35 7/8"  | 47 1/4"  | 50 3/4"  | 7/8"     | 14 7/8"  | 33 3/4"  | 49 1/8"  | 95 1/8"  | 37°      |
| GTL 1120        | 1900-0520 | 49 1/4"  | 8 1/2"   | 35 7/8"  | 54 3/8"  | 59 5/8"  | 7/8"     | 13 7/8"  | 35 7/8"  | 56 5/8"  | 104 1/2" | 46°      |
| GTL 2228        | 1900-0528 | 57 1/4"  | 8 1/2"   | 35 7/8"  | 70 3/8"  | 75 5/8"  | 7/8"     | 13 7/8"  | 35 5/8"  | 72 7/8"  | 120 5/8" | 45°      |

**CONFIDENTIAL**  
 THE INFORMATION CONTAINED IN THIS DRAWING IS THE PROPERTY OF BAYNE MACHINE WORKS, INC. AND IS NOT TO BE REPRODUCED OR TRANSMITTED IN ANY FORM OR BY ANY MEANS, ELECTRONIC OR MECHANICAL, INCLUDING PHOTOCOPYING, RECORDING, OR BY ANY INFORMATION STORAGE AND RETRIEVAL SYSTEM. ANY UNAUTHORIZED USE OF THIS DRAWING IS STRICTLY PROHIBITED. ANY VIOLATION OF THIS NOTICE IS SUBJECT TO LEGAL ACTION.

**UNLESS OTHERWISE SPECIFIED DIMENSIONS ARE IN INCHES LINEAR TOLERANCES: ±.005 ANGULAR TOLERANCES: ±.010 DEG**

**BAYNE MACHINE WORKS, INC.**  
 910 FORK SHOALS ROAD - GREENVILLE, SC 29605 - 864.288.3877

**GTL SERIES SPECIFICATIONS**

TITLE: GTL SERIES SPECIFICATIONS  
 DRAWN BY: CTT DATE: 10/20/2009 SCALE: NONE SHEET OF: 2  
 CHECKED BY: DATE: DWG NO: H5400003 REV: -

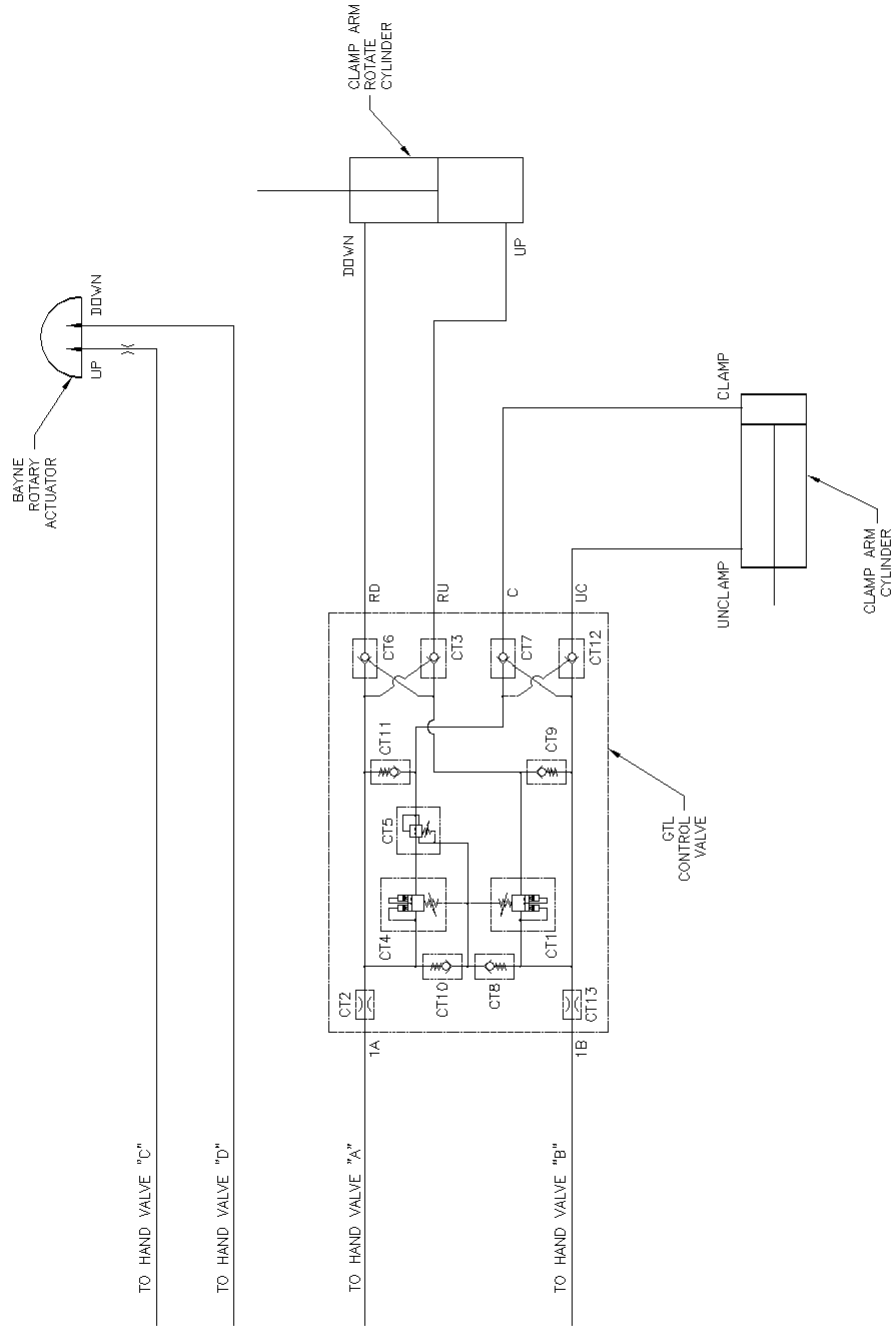

|  |   |                                       |              |                     |
|--|---|---------------------------------------|--------------|---------------------|
| <b>CONFIDENTIAL</b>  | This drawing is private and confidential communication and the property of BAYNE MACHINE WORKS, INC., Greenville, S.C. It MUST NOT be copied or lent without consent of BAYNE MACHINE WORKS, INC., and must be promptly returned with tender and/or completion of order to the purchasing department. | SCALE: 1=1                            | SHEET 1 OF 1 | REV. -              |
| <b>BAYNE MACHINE WORKS, INC.</b><br>910 FORK SHOALS ROAD - GREENVILLE, SC 29608 - 864.288.3877 | TOLERANCES IF NOT NOTED:<br>0.000 ±0.005 - 0.00 +0.015<br>Ø/Ø ±1/32 - ANGULAR ±0.25   | TITLE: GTL LIFTER HYDRAULIC SCHEMATIC |              | DWG. NO.: 6900-0243 |
| DATE: 12/23/99   | CHK'D BY: CTT   | DATE: 12/23/99                        | DATE:        |                     |



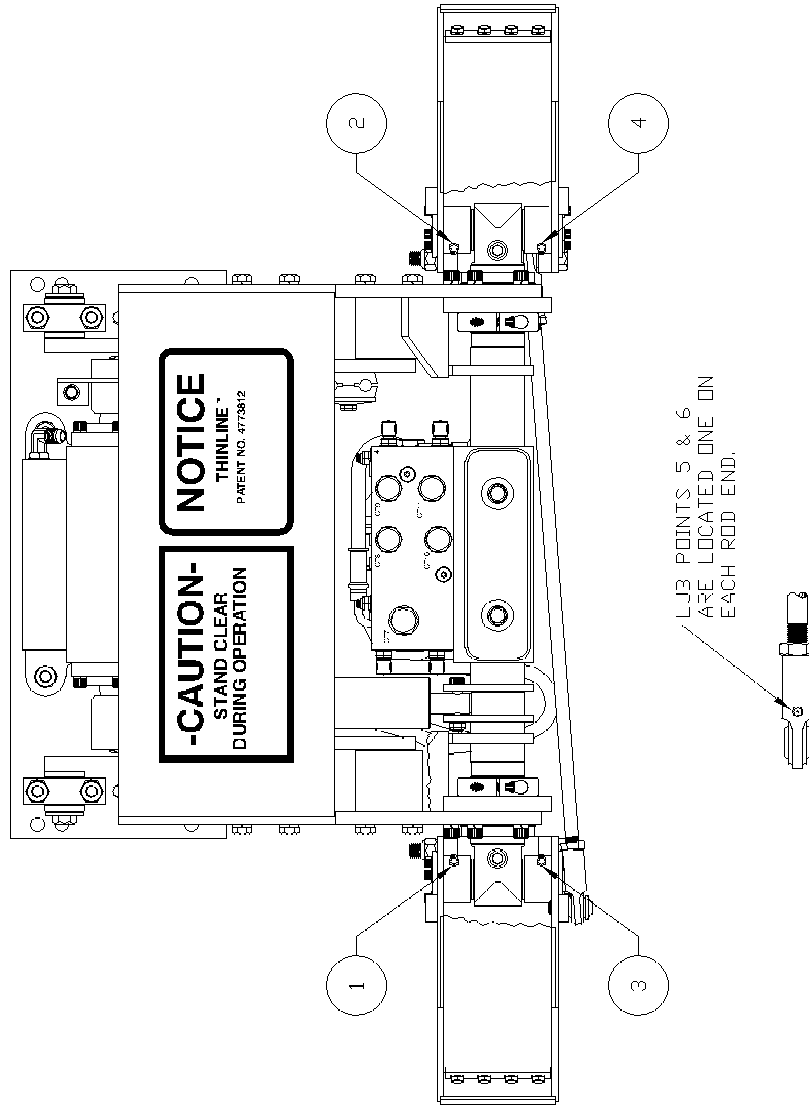

**-CAUTION-**  
STAND CLEAR  
DURING OPERATION

**NOTICE**  
THINLINE™  
PATENT NO. 477-8812

|  |  |   |          |                    |       |           |      |
|--|--|---|----------|--------------------|-------|-----------|------|
| <b>CONFIDENTIAL</b>  |  | This drawing is private and confidential communication and the property of BAYNE MACHINE WORKS, INC., Greenville, S.C. It MUST NOT be copied or lent without consent of BAYNE MACHINE WORKS, INC., and must be promptly returned with tender and/or completion of order to the purchasing department. |          | SCALE:             | SHEET | OF        | REV. |
| BAYNE MACHINE WORKS, INC.<br>90 DORR SHOALS ROAD - GREENVILLE, SC 29635 - 864-282-3377 |  | DATE:   | CHKD BY: | 1=4                | 1     | 1         | -    |
| TOLERANCES IF NOT NOTED:<br>D/C = 0.005 - 0.00 - 0.0 - 5<br>3/C = 1/32 - ANGULAR ±0.25 |  | DATE:   | CHKD BY: | TITLE:             |       | DWG. NO.: |      |
|  |  | 12/15/99  | C-T      | LUBRICATION POINTS |       | LUB4100   |      |



[www.baynethinline.com](http://www.baynethinline.com)

Customer Care:  
800.535.2671

Fax:  
256.585.6762

The Heil Co.  
4301 Gault Avenue North  
Fort Payne, AL 35967