



# M-SERIES

## Compactor Cart Lifters

**Versatile, Powerful, & Reliable**

### **Bayne Thinline Premium Lift Systems. Lifting Ergonomics To New Heights.**

The M-Series of cylinder lifts from Bayne® Thinline® Premium Lift Systems was designed for the hauler who is looking for an economical, quality-built compactor cart lifter.

In addition to compactors, this series of lifts can be mounted on a stationary frame to offer a safety-conscious solution for a wide variety of material handling applications.

#### **M-Series Features:**

- Excellent for compactor applications
- Sweeping action provides a greater “pick-up” envelope for lifting carts on uneven terrain
- Lift capacity of 1,000 lbs.
- Steep 45° dump angle
- Dumps well inside hopper to prevent spillage
- Non-adjustable hook drive mechanism automatically secures cart during dump cycle
- Mounting-plate kit for bolt-on applications



**Premium Lift Systems**

### **Precision, Quality, and Patented Engineering**

For more information: Toll Free: 800-528-5308 | [www.baynethinline.com](http://www.baynethinline.com)

Bayne Thinline Premium Lift Systems | 4301 Gault Ave. North | Fort Payne, AL 35967

© Copyright 2024 Bayne Thinline All rights reserved



# M-SERIES

## Specifications & Dimensions

### M-SERIES PERFORMANCE SPECIFICATIONS

Cart Compatibility	ANSI Z245.60-1996 Type B Containers (standard domestic 2-bar)
Lift Capacity	1,000 lbs. @ 1,500 psi
Hydraulic Pressure	Working Pressure – 1,500 psi, Maximum Pressure – 2,500 psi
Hydraulic Flow	2.5 gpm
Cycle Time	15 Seconds
Lubrication	Greaseless "Zerks"
Cylinder	Heavy-Duty Tie-Rod Cylinder, 3" Bore x 8" Stroke
Finish	Safety Yellow Powder-Coating
Options	Mounting-Plate Kit For Bolt-On Application
	Feed Chute
	Flow Control Kit
	Hydraulic Power Unit / Tap-In Kit

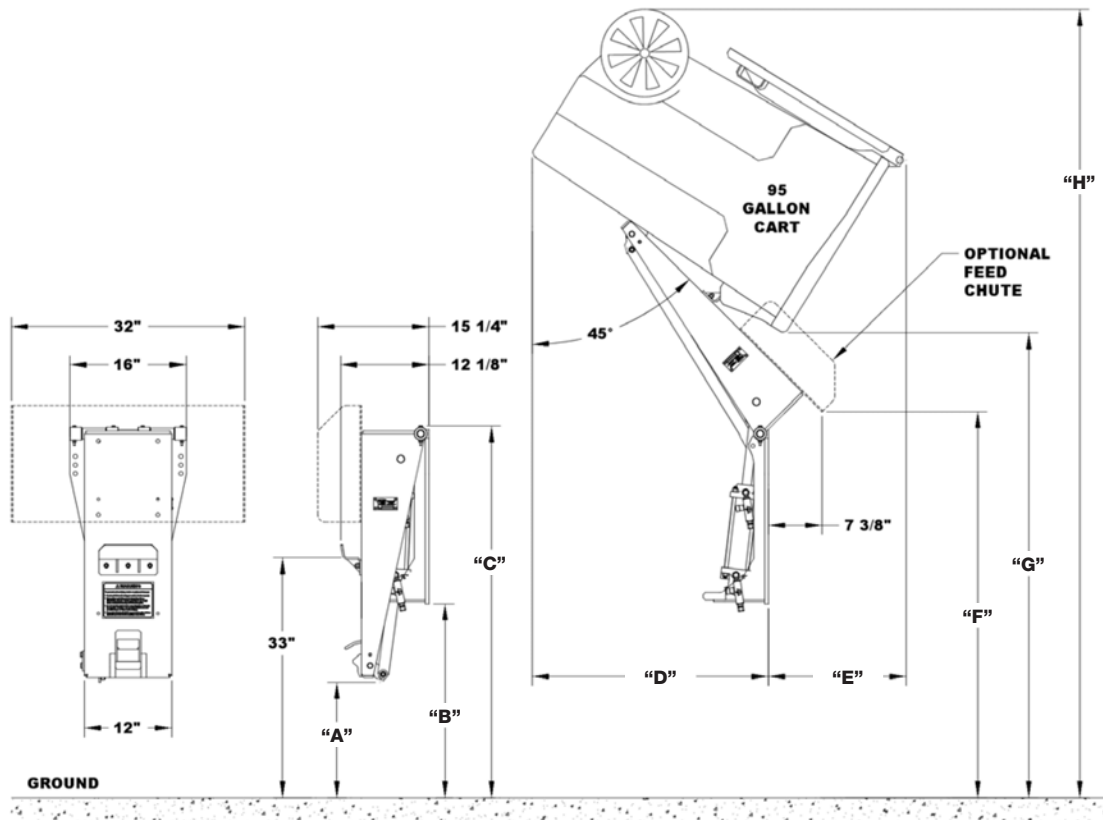

MODEL NUMBER	"A"	"B"	"C"	"D"	"E"	"F"	"G"	"H"
M-440	15 3/4"	22 5/8"	47"	29 5/8"	21 3/4"	49"	57"	101 3/8"
M-480	15 7/8"	26 5/8"	51"	32 3/8"	18 7/8"	53"	63 7/8"	108 1/4"

Pictures and mechanical diagrams in this literature are illustrative only and may not be to scale. Specifications are subject to change without notice in order to accommodate improvements to the equipment. Data published herein is for information purposes only and shall not be construed to warrant suitability of the unit for any particular purpose, as performance may vary with the conditions encountered. The only warranty is our standard written Warranty Statement for this product at the time of shipment.



Premium Lift Systems

Toll Free: 800-528-5308 | [www.baynethinline.com](http://www.baynethinline.com)

Bayne Thinline Premium Lift Systems | 4301 Gault Ave. North | Fort Payne, AL 35967

© Copyright 2024 Bayne Thinline All rights reserved

