



# GTL SERIES

Mobile Refuse Cart Lifter

## Maximizing Route Safety & Efficiency

### Bayne Thinline Premium Lift Systems. Lifting Ergonomics To New Heights.

The Grabber products are the most versatile series of lifters from Bayne® Thinline® Premium Lift Systems. These products were specifically designed for the hauler who must pick up a variety of different residential roll-out carts on the same route. The GTL series is the original grabber unit designed by Bayne Thinline and is used primarily on side-load and front-load applications.

#### GTL Series Features:

- Powered by the patented Bayne Thinline rack-and-pinion rotary actuator for smooth operation
- Compatible with both semi-automated and fully automated roll-out carts
- Excellent backup for fully automated collection vehicles
- Dumps cart higher and deeper inside the hopper opening to prevent spillage and increase route stops before needing to cycle the packer panel
- Self-lubricating composite bearings at main pivot points
- Powder-coated finish for durability
- 2-Year Limited Warranty



Premium Lift Systems

### Precision, Quality, and Patented Engineering

For more information: Toll Free: 800-528-5308 | [www.baynethinline.com](http://www.baynethinline.com)

Bayne Thinline Premium Lift Systems | 4301 Gault Ave. North | Fort Payne, AL 35967

# GTL SERIES

## Specifications & Dimensions

### PERFORMANCE SPECIFICATIONS

Cart Compatibility	ANSI Z245.60-2006 Type B Carts (domestic style 2-bar) ANSI Z245.60-2006 Type C Carts (European style) ANSI Z245.60-2006 Type D Carts (pocketed style) ANSI Z245.60-2006 Type G Carts (automated style) Standard size 30 and 55 gallon drums
Lift Capacity	400 lbs. @ 1800 psi
Hydraulic Pressure	Working Pressure – 1800 psi Maximum Pressure – 2500 psi
Hydraulic Flow	2.0 – 2.5 gpm
Cycle Time	10 – 12 seconds
Bearings	Self-Lubricating Composite Material
Actuator	Patented Bayne® Thinline® rack-and-pinion rotary actuator
Finish	Safety yellow powder-coating
Options	Tap-in Kit
	Mounting-plate kit for bolt-on application



### How It Works:

The Bayne Thinline GTL Series was specifically designed to operate with the fewest moving parts possible, making it one of the most reliable Lifters on the Market. This Lifter specializes in picking up two-bar carts high into the hopper, emptying more trash per dump, all while saving fuel and operating costs.

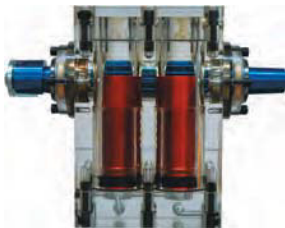

Patented Bayne Thinline Rack-and-Pinion Rotary Actuator

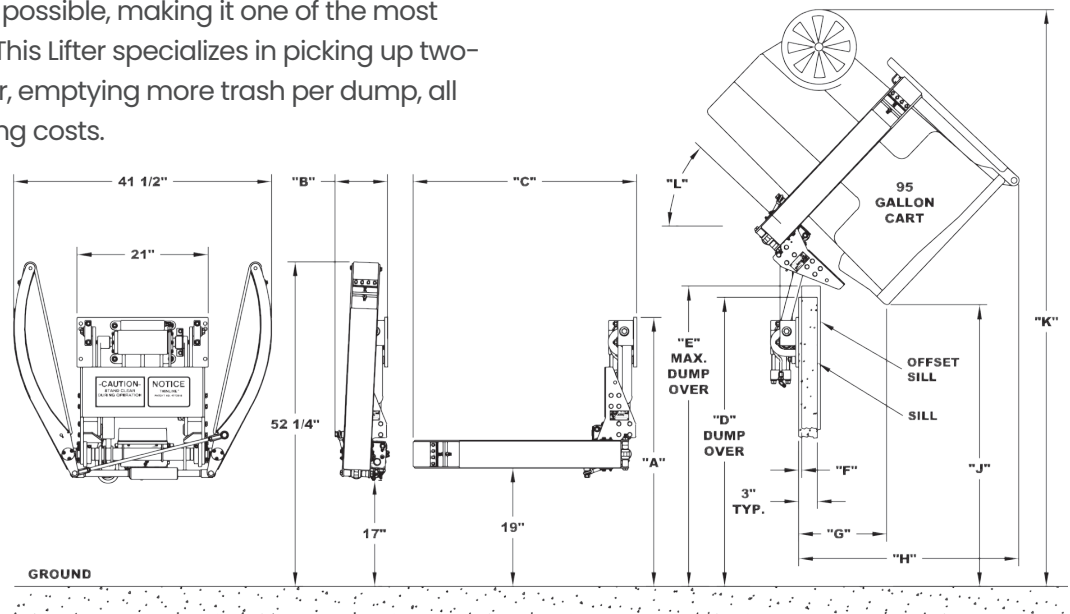

MODEL NUMBER	"A"	"B"	"C"	"D"	"E"	"F"	"G"	"H"	"J"	"K"	"L"
GTL 1110	39 1/4"	8 1/2"	35 7/8"	40"	40 1/4"	1/8"	14 1/4"	35 1/4"	37 3/8"	84 3/4"	43"
GTL 1114	43 1/4"	8 1/2"	35 7/8"	45 3/4"	48"	5/8"	14 1/8"	35 3/8"	45 1/4"	92 3/4"	43"
GTL 1120	49 1/4"	8 1/2"	35 7/8"	54 3/8"	59 5/8"	7/8"	13 7/8"	35 7/8"	56 5/8"	104 1/2"	46"

Pictures and mechanical diagrams in this literature are illustrative only and may not be to scale. Specifications are subject to change without notice in order to accommodate improvements to the equipment. Data published herein is for information purposes only and shall not be construed to warrant suitability of the unit for any particular purpose, as performance may vary with the conditions encountered. The only warranty is our standard written Warranty Statement for this product at the time of shipment.



Premium Lift Systems

Toll Free: 800-528-5308 | [www.baynethinline.com](http://www.baynethinline.com)

Bayne Thinline Premium Lift Systems | 4301 Gault Ave. North | Fort Payne, AL 35967

© Copyright 2024 Bayne Thinline All rights reserved

