



BTL SERIES

Mobile Refuse Cart Lifter

Maximizing Route Safety & Efficiency

Bayne Thinline Premium Lift Systems. Lifting Ergonomics To New Heights.

The BTL series is one of the best-selling lines of lifters from Bayne® Thinline® Premium Lift Systems. This lifter was specifically designed to offer greater ground clearance for rear-load applications, thus reducing the risk of damaging the lifter on uneven terrain such as alley entrances, landfills, etc. This additional ground clearance makes the BTL a perfect choice for rear-load applications with commercial container lift bars.

BTL Series Features:

- Powered by the patented Bayne Thinline rack-and-pinion rotary actuator for smooth operation
- Compatible with standard domestic style 2-bar carts
- Over 21" of ground clearance
- The Bayne Thinline design works in conjunction with most commercial container lift bars
- Dumps cart higher and deeper inside the hopper opening to prevent spillage and increase route stops before needing to cycle the packer panel
- Self-lubricating composite bearings at main pivot points
- Powder-coated finish for durability
- 2-Year Limited Warranty



Premium Lift Systems

Precision, Quality, and Patented Engineering

For more information: Toll Free: 800-528-5308 | www.baynethinline.com

Bayne Thinline Premium Lift Systems | 4301 Gault Ave. North | Fort Payne, AL 35967

BTL SERIES

Specifications & Dimensions

PERFORMANCE SPECIFICATIONS

Cart Compatibility	ANSI Z 245.60-2008 Type B carts (domestic style 2-bar)
Lift Capacity	400 lbs. @ 1800 psi
Hydraulic Pressure	Maximum pressure - 3000 psi
Hydraulic Flow	2.0 - 2.5 gpm
Cycle Time	6 - 8 seconds (lifter only)
Bearings	Self-lubricating composite material
Actuator	Patented Bayne® Thinline® rack-and-pinion rotary actuator
Finish	Safety yellow powder-coating
Options	Tap-in Kit
	Mounting-plate kit for bolt-on application



How It Works:

The patented Bayne Thinline design incorporates a sweeping action that automatically adjusts for uneven terrain, preventing operators from having to manually hoist carts onto the lift plate. The BTL Series was specifically designed to offer the most ground clearance possible for rear-load garbage truck applications. The BTL Series also works with rear-loaders that utilize a commercial container kick bar.

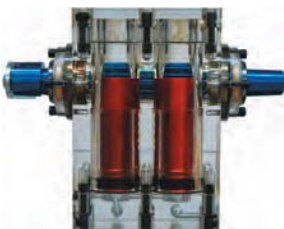

Patented Bayne Thinline Rack-and-Pinion Rotary Actuator

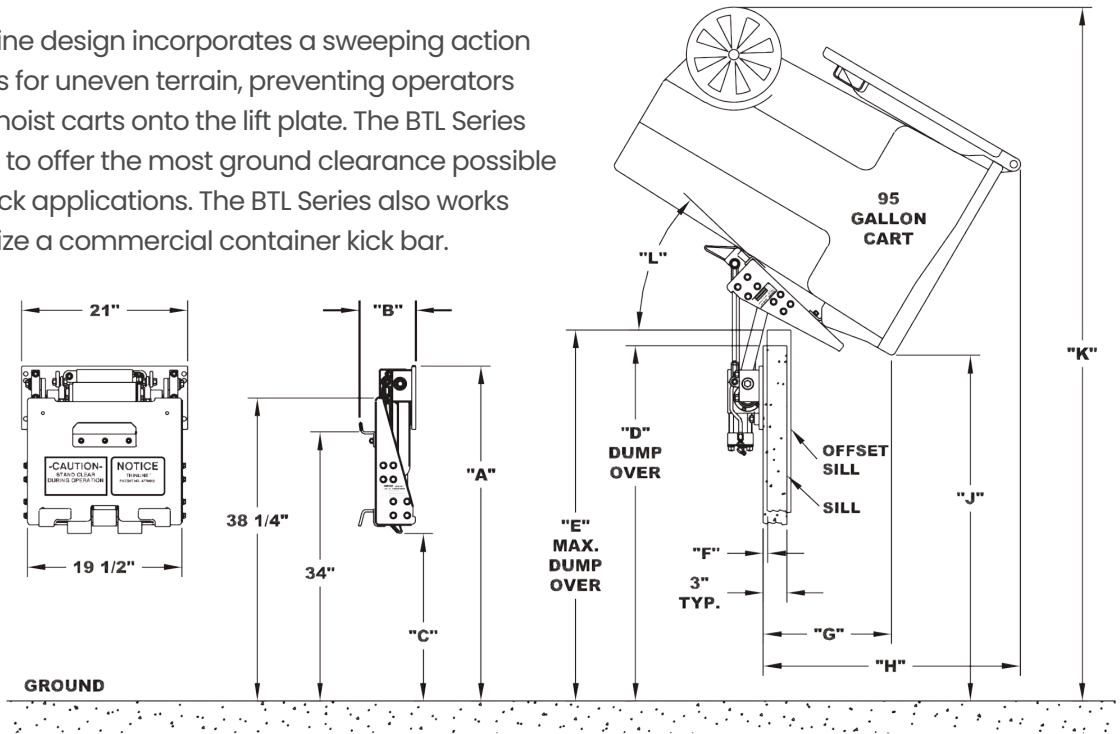

MODEL NUMBER	"A"	"B"	"C"	"D"	"E"	"F"	"G"	"H"	"J"	"K"	"L"
BTL 1110	38 1/4"	7 1/8"	21 1/4"	39 1/8"	N/A	N/A	16 1/4"	32 3/8"	35 3/4"	79 5/8"	43"
BTL 1112	40 1/4"	7 1/8"	21 3/8"	42"	43 1/4"	3/8"	16 5/8"	31 1/2"	40 3/4"	83 1/2"	40"
BTL 1114	42 1/4"	7 1/8"	21 1/8"	44 3/4"	46 5/8"	1/2"	16 1/4"	32 1/2"	43 5/8"	87 5/8"	43"

Pictures and mechanical diagrams in this literature are illustrative only and may not be to scale. Specifications are subject to change without notice in order to accommodate improvements to the equipment. Data published herein is for information purposes only and shall not be construed to warrant suitability of the unit for any particular purpose, as performance may vary with the conditions encountered. The only warranty is our standard written Warranty Statement for this product at the time of shipment.



Premium Lift Systems

Toll Free: 800-528-5308 | www.baynethinline.com

Bayne Thinline Premium Lift Systems | 4301 Gault Ave. North | Fort Payne, AL 35967

© Copyright 2024 Bayne Thinline All rights reserved

