



TASKMASTER HI-LIFT AND TASKMASTER SUPER HI-LIFT

Mobile Refuse & Compactor Cart Lifters

Versatile, Powerful, & Reliable

Bayne Thinline Premium Lift Systems. Lifting Ergonomics To New Heights.

The Taskmaster Hi-Lift and Taskmaster Super Hi-Lift cylinder lifts from Bayne® Thinline® Premium Lift Systems was designed for the hauler who is looking for an economical, quality-built cart lifter. In addition to side-load collection vehicles, this series of Taskmaster lifts can be mounted on a stationary frame or compactor to offer a safety-conscious solution for a wide variety of material handling applications.

Taskmaster Hi-Lift & Taskmaster Super Hi-Lift Features:

- Excellent for side-load and compactor applications (not compatible with rear-loaders)
- Sweeping action provides a greater “pick-up” envelope for lifting carts on uneven terrain
- Dumps well inside hopper to prevent spillage
- Composite bearings eliminate the need for greasing
- Non-adjustable hook drive mechanism automatically secures cart during dump cycle
- Mounting-plate kit for bolt-on applications



Premium Lift Systems

Precision, Quality, and Patented Engineering

For more information: Toll Free: 800-528-5308 | www.baynethinline.com

Bayne Thinline Premium Lift Systems | 4301 Gault Ave. North | Fort Payne, AL 35967

© Copyright 2024 Bayne Thinline All rights reserved



TASKMASTER HI-LIFT & SUPER HI-LIFT

Specifications & Dimensions

Taskmaster Hi-Lift Features:

- Extra high 61" dump-over height allows more carts to be dumped per packing cycle
- Compatible with all standard 2-bar domestic carts
- Steep 45° dump angle
- Lift capacity of 500 lbs. @ 1,200 PSI
- 6 - 8 second cycle time @ 3.0 GPM



Taskmaster Super Hi-Lift Features:

- 57" dump-over height
- Compatible with standard domestic style 2-bar carts, as well as ½ yd and 1 yd material-handling carts
- 40° dump angle
- 500 lbs. lift capacity @ 1,800 PSI
- 8 - 10 second cycle time @ 2.5 GPM

Pictures and mechanical diagrams in this literature are illustrative only and may not be to scale. Specifications are subject to change without notice in order to accommodate improvements to the equipment. Data published herein is for information purposes only and shall not be construed to warrant suitability of the unit for any particular purpose, as performance may vary with the conditions encountered. The only warranty is our standard written Warranty Statement for this product at the time of shipment.



Premium Lift Systems

Toll Free: 800-528-5308 | www.baynethinline.com

Bayne Thinline Premium Lift Systems | 4301 Gault Ave. North | Fort Payne, AL 35967

© Copyright 2024 Bayne Thinline All rights reserved



TASKMASTER HI-LIFT

Specifications & Dimensions

TASKMASTER HI-LIFT PERFORMANCE SPECIFICATIONS	
Cart Compatibility	ANSI Z245.60-1996 Type B Containers (standard domestic 2-bar)
Lift Capacity	500 lbs. @ 1,200 psi
Hydraulic Pressure	Working Pressure – 1,200 psi, Maximum Pressure – 2,500 psi
Hydraulic Flow	2.5 – 3.0 gpm
Cycle Time	6 – 8 Seconds
Sill Height	48"
Bearings	Greaseless Composite Material
Cylinder	Welded Construction With Replaceable Seals
Finish	Safety Yellow Powder-Coating
Options	Tap-in Kit (diverter valve, hand valve, hoses & fittings)
	Mounting-Plate Kit For Bolt-On Application

- NOTE:
1. DIMENSIONS ACCOMMODATE ANSI Z245.60-1996 TYPE B (TWO-BAR) CONTAINERS, BUT MAY VARY DUE TO CONTAINER SPECIFICATIONS OR APPLICATIONS.
 2. ALL DIMENSIONS ARE APPROXIMATE.
 3. SHOWN WITH MOUNTING PLATE KIT 4900-1030 FOR BOLT-ON APPLICATIONS.

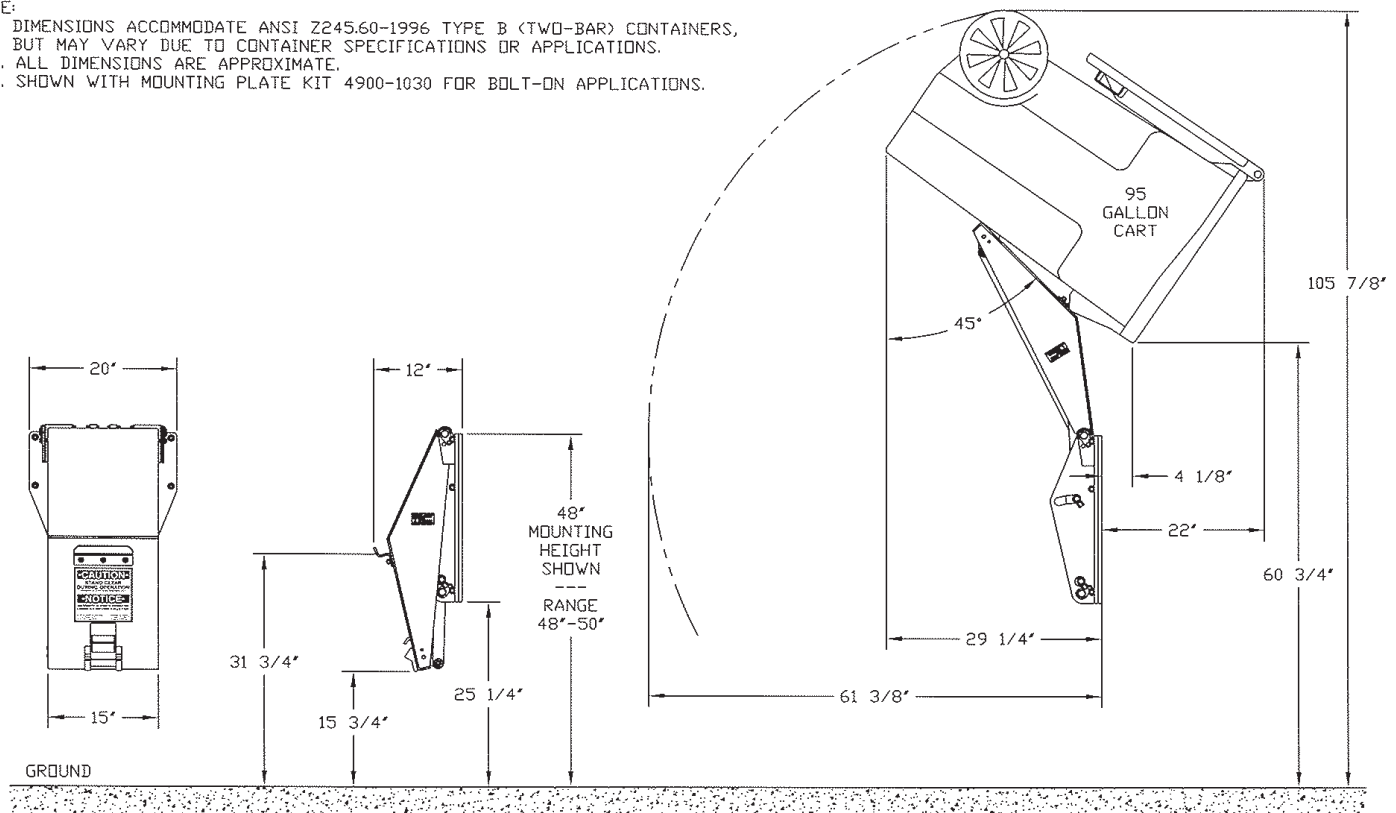

Pictures and mechanical diagrams in this literature are illustrative only and may not be to scale. Specifications are subject to change without notice in order to accommodate improvements to the equipment. Data published herein is for information purposes only and shall not be construed to warrant suitability of the unit for any particular purpose, as performance may vary with the conditions encountered. The only warranty is our standard written Warranty Statement for this product at the time of shipment.



Premium Lift Systems

Toll Free: 800-528-5308 | www.baynethinline.com

Bayne Thinline Premium Lift Systems | 4301 Gault Ave. North | Fort Payne, AL 35967

© Copyright 2024 Bayne Thinline All rights reserved



TASKMASTER SUPER HI-LIFT

Specifications & Dimensions

TASKMASTER SUPER HI-LIFT PERFORMANCE SPECIFICATIONS	
Cart Compatibility	ANSI Z245.60-2008 Type B Containers (standard domestic 2-bar) Plus ½ yd. and 1 yd. Material-Handling Carts
Lift Capacity	500 lbs. @ 1,800
Hydraulic Pressure	Working Pressure – 1,200 psi, Maximum Pressure – 2,500 psi
Hydraulic Flow	2.0 - 2.5 gpm
Cycle Time	8 – 10 Seconds
Sill Height	50"
Bearings	Greaseless Composite Material
Cylinder	Welded Construction with Replaceable Seals
Finish	Safety Yellow Powder-Coating
Options	Tap-In Kit (diverter valve, hand valve, hoses & fittings)
	Mounting-Plate Kit for Bolt-On Application

NOTE:

1. DIMENSIONS ACCOMMODATE ANSI Z245.60-2008 TYPE B CONTAINERS (DOMESTIC 2-BAR CARTS), BUT MAY VARY DUE TO CONTAINER SPECIFICATIONS OR APPLICATIONS.
2. ALL DIMENSIONS ARE APPROXIMATE.
3. FOR BOLT-ON APPLICATIONS USE MOUNTING PLATE KIT 4900-1030.
4. PART NUMBERS: 1999-9200 - TASKMASTER SUPER HI-LIFT

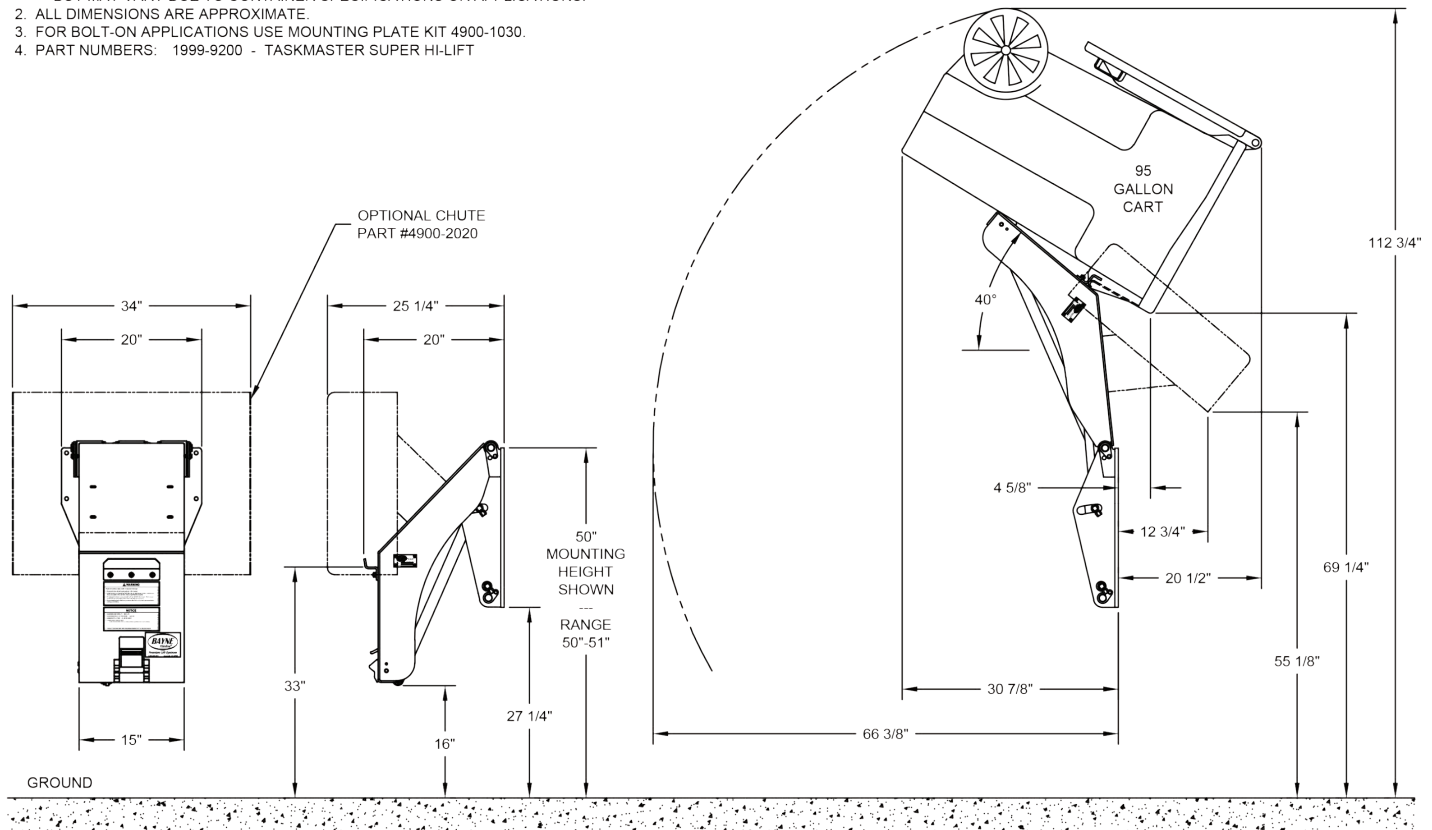

Pictures and mechanical diagrams in this literature are illustrative only and may not be to scale. Specifications are subject to change without notice in order to accommodate improvements to the equipment. Data published herein is for information purposes only and shall not be construed to warrant suitability of the unit for any particular purpose, as performance may vary with the conditions encountered. The only warranty is our standard written Warranty Statement for this product at the time of shipment.



Premium Lift Systems

Toll Free: 800-528-5308 | www.baynethinline.com

Bayne Thinline Premium Lift Systems | 4301 Gault Ave. North | Fort Payne, AL 35967

© Copyright 2024 Bayne Thinline All rights reserved

