



TL SERIES

Mobile Refuse Cart Lifter

Maximizing Route Safety & Efficiency.

Bayne Thinline Premium Lift Systems. Lifting Ergonomics To New Heights.

The TL series is one of the best selling lines of lifters from Bayne® Thinline® Premium Lift Systems. This lifter was specifically designed to operate with the fewest moving parts possible, making it one of the most reliable lifters on the market. The TL Series is available in two weight-lifting capacities. The 400 lb. model is ideal for standard pick up, and the 700 lb. capacity is perfect for heavier pick ups.

TL Series Features:

- Powered by the patented Bayne Thinline rack-and-pinion rotary actuator for smooth operation
- Compatible with standard domestic style 2-bar roll-out carts
- The Bayne Thinline design works in conjunction with most commercial container latch kits
- Fewer moving parts results in superior reliability
- Dumps cart higher and deeper inside the hopper opening to prevent spillage and increase route stops before needing to cycle the packer panel
- Self-lubricating composite bearings at main pivot points
- Powder-coated finish for durability
- 2-Year Limited Warranty



Premium Lift Systems

Precision, Quality, and Patented Engineering

For more information: Toll Free: 800-528-5308 | www.baynethinline.com
Bayne Thinline Premium Lift Systems | 4301 Gault Ave. North | Fort Payne, AL 35967

TL SERIES

Specifications & Dimensions

PERFORMANCE SPECIFICATIONS	
Cart Compatibility	ANSI Z 245.60-2006 Type B Carts (domestic style 2-bar)
Lift Capacity	1100 Actuator (Designed for lifting Residential Containers in Mobile applications): 400 lbs @ 1800 psi (16", 20", 24" arms) 300 lbs @ 1800 psi (28", 32", 34" arms) 2200 Actuator (Designed for lifting non-residential containers): 700 lbs @ 1800 psi (16", 20", 24" arms) 500 lbs @ 1800 psi (28", 32", 34" arms)
Hydraulic Pressure	Working Pressure – 1800 psi Maximum Pressure – 2500 psi
Hydraulic Flow	2.0 – 2.5 gpm
Cycle Time	6 – 8 seconds
Bearings	Self-Lubricating Composite Material
Actuator	Patented Bayne® Thinline® rack-and-pinion rotary actuator
Finish	Safety yellow powder-coating
Options	Tap-in Kit
	Mounting-plate kit for bolt-on application



How It Works:

The patented Bayne Thinline design incorporates a sweeping action that automatically adjusts for uneven terrain, preventing operators from having to manually hoist carts onto the lift plate. The TL Series was specifically designed to operate with the fewest moving parts possible, making it one of the most reliable lifters on the market. This lifter specializes in picking up two-bar carts high into the hopper, emptying more trash per dump, all while saving fuel and operating costs.

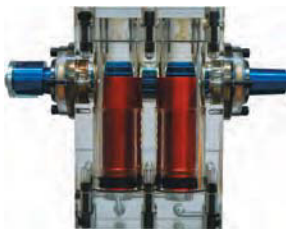
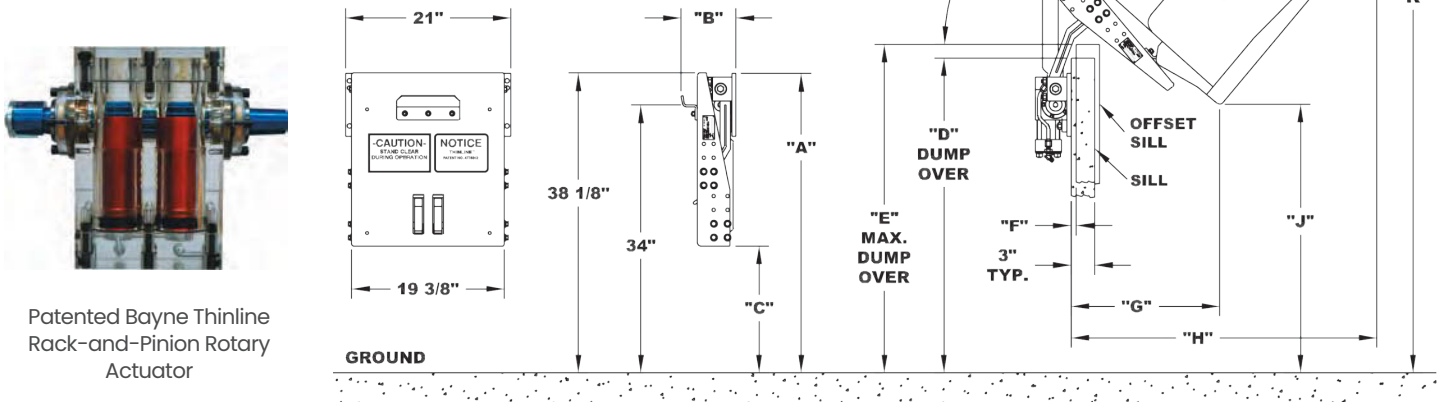

Patented Bayne Thinline
Rack-and-Pinion Rotary
Actuator

MODEL NUMBER	"A"	"B"	"C"	"D"	"E"	"F"	"G"	"H"	"J"	"K"	"L"
TL 1116	38"	7"	16 1/8"	40"	41 3/4"	5/8"	18 7/8"	38 3/4"	34 1/8"	80 3/4"	50"
TL 1120	42"	7"	16 1/8"	45 3/8"	49 3/4"	1 1/4"	19 5/8"	38 1/2"	43 1/4"	89 1/8"	47"
TL 1124	46"	7"	16 1/8"	50 1/8"	57 5/8"	1 5/8"	20"	38 1/4"	51 7/8"	97 3/8"	45"

Pictures and mechanical diagrams in this literature are illustrative only and may not be to scale. Specifications are subject to change without notice in order to accommodate improvements to the equipment. Data published herein is for information purposes only and shall not be construed to warrant suitability of the unit for any particular purpose, as performance may vary with the conditions encountered. The only warranty is our standard written Warranty Statement for this product at the time of shipment.



Premium Lift Systems

Toll Free: 800-528-5308 | www.baynethinline.com

Bayne Thinline Premium Lift Systems | 4301 Gault Ave. North | Fort Payne, AL 35967

© Copyright 2024 Bayne Thinline All rights reserved

